



SITE NAME: SPRING LAKE FIRE STATION #43
SITE NUMBER: SA13XC135
STRUCTURE TYPE: MONOPOLE
MARKET: SAN ANTONIO
RFDS REVISION: V B1 (07/12/2012)

PREPARED FOR:



1 INTERNATIONAL BOULEVARD
 SUITE #800
 MAHWAH, N.J. 07495

CONSULTANT:



POWDER RIVER
 Development Services, LLC

100 E. SHENANGO STREET
 SHARPSVILLE, PA 16150

724.962.5999

www.powderriverdev.com

PRDS PROJ.NO. 1181-081911

SITE NAME:
SPRING LAKE
FIRE STATION #43

SITE NUMBER:
SA13XC135

SITE ADDRESS:
 2059 W. BITTERS ROAD
 SAN ANTONIO, TX 78248

STAMP:

I CERTIFY THAT THESE DRAWINGS WERE PREPARED BY ME OR UNDER MY DIRECT SUPERVISION AND TO THE BEST OF MY KNOWLEDGE AND BELIEF COMPLY WITH THE REQUIREMENTS OF THE INTERNATIONAL BUILDING CODE, 2009 EDITION.

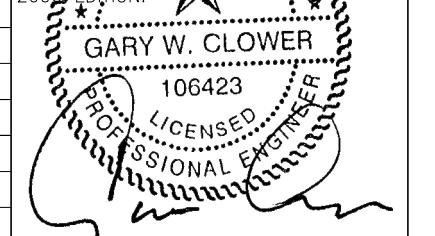

PROJECT SUMMARY	DRIVING DIRECTIONS	VICINITY MAP	LIST OF DRAWINGS
SITE NAME: SPRING LAKE FIRE STATION #43 SITE NUMBER: SA13XC135 911 ADDRESS: 2059 W. BITTERS RD SAN ANTONIO, TX 78248 APN#: LATTITUDE: 29.5947 LONGITUDE: -98.5308 GROUND ELEVATION: JURISDICTION: BEXAR COUNTY	FROM AIRPORT: DEPART AIRPORT BLVD TOWARD AIRPORT EXIT, ROAD NAME CHANGES TO AIRPORT EXIT, TURN RIGHT ONTO AIRPORT BLVD, KEEP STRAIGHT ONTO AIRPORT EXIT, TURN RIGHT ONTO S TERMINAL DR, TURN RIGHT ONTO N US-281, TAKE RAMP LEFT AND FOLLOW SIGNS FOR US-281 NORTH,(EMBASSY SUITES ON THE CORNER), TAKE RAMP RIGHT FOR N US-281 TOWARD BITTERS RD, TURN LEFT ONTO E BITTERS RD, KEEP STRAIGHT ONTO W BITTERS RD, ARRIVE AT 2059 W BITTERS RD, SAN ANTONIO, TX 78248-1604		SITE GENERAL ARRANGEMENT PLANS T-1 TITLE SHEET T-2 GENERAL NOTES T-3 GENERAL NOTES T-4 GENERAL NOTES ARCHITECTURAL / CIVIL PLANS A-1 OVERALL SITE PLAN A-2 ENLARGED SITE PLAN A-3 EQUIPMENT PLANS A-4 SITE ELEVATION & ANTENNA DETAILS A-5 EQUIPMENT SCHEDULES & RFDS A-6 ANTENNA PLUMBING DIAGRAM A-7 ENLARGED ANTENNA PLANS & COAX RUN DIAGRAM A-8 (E) COLOR CODING A-9 (N) COLOR CODING A-10 DETAILS A-11 DETAILS ELECTRICAL PLANS E-1 ELECTRICAL PLAN & DETAILS E-2 POWER/TELCO DIAGRAMS E-3 GROUNDING PLANS - FINAL E-4 ELECTRICAL DETAILS E-5 GROUNDING DETAILS E-6 GROUNDING DETAILS
SCOPE OF WORK	CONTACTS	APPROVALS	
1) THE WIRELESS COMMUNICATIONS FACILITY IS NOT INTENDED FOR HUMAN OCCUPANCY 2) THIS FACILITY DOES NOT REQUIRE POTABLE WATER AND WILL NOT PRODUCE ANY SEWAGE. 3) THE SCOPE OF WORK CONSISTS OF MODIFYING THE EXISTING WIRELESS INSTALLATION: A. REMOVAL OF (6) EXISTING EQUIPMENT CABINET B. INSTALLATION OF (2) NEW EQUIPMENT CABINET C. REMOVAL OF (6) EXISTING ANTENNAS D. INSTALLATION OF (3) NEW ANTENNAS E. INSTALLATION OF (12) NEW RRUS (REMOTE RADIO UNITS)	APPLICANT: SPRINT PCS 1 INTERNATIONAL BOULEVARD SUITE #800 MAHWAH, N.J. 07495 201-684-4000 TOWER OWNER: CITY OF SAN ANTONIO - ITDS 515 S FRIO STREET SAN ANTONIO, TX 78207-5009 PHONE: 210-207-2779 ARCHITECT/ENGINEER: POWDER RIVER DEVELOPMENT SERVICES, LLC. 100 E. SHENANGO STREET SHARPSVILLE, PA 16150 CONTACT: GARY CLOWER, P.E. PHONE: 724-962-5999 SURVEYOR: NA TELEPHONE COMPANY: SBC/AT&T PHONE: 877-754-4798 POWER COMPANY: CPS PHONE: 800-870-1006	ERICSSON CM DATE ERICSSON SAM DATE ERICSSON RF DATE SITE OWNER DATE ERICSSON CPM DATE THE ABOVE PARTIES HEREBY APPROVE AND ACCEPT THESE DOCUMENTS AND AUTHORIZE CONTRACTOR TO PROCEED WITH THE CONSTRUCTION DESCRIBED HEREIN. ALL DOCUMENTS ARE SUBJECT TO REVIEW BY THE LOCAL BUILDING DEPARTMENT AND MAY IMPOSE CHANGES OR MODIFICATIONS.	NOTE: DRAWING SCALES ARE FOR 24"x36" SHEETS UNLESS OTHERWISE NOTED.
APPLICABLE CODES & STANDARDS	SITE ACCESS PROCEDURES		
- INTERNATIONAL BUILDING CODE, 2012 EDITION AS ADOPTED BY LOCAL JURISDICTION. - NATIONAL ELECTRICAL CODE, 2011 EDITION AS ADOPTED BY LOCAL JURISDICTION. - UNIFORM MECHANICAL CODE, 2012 EDITION AS ADOPTED BY LOCAL JURISDICTION. - INTERNATIONAL ENERGY CONSERVATION CODE, 2009 CITY OF SAN ANTONIO COMMERCIAL ENERGY CODE (ANSI/ASHRAE/IESNA 90.1-2004)			



Know what's below.
 Call 811 Before You Dig

DRAWN BY:	KE		
APPROVED BY:	G.W.C.		
DATE DRAWN:	09/07/11		
REVISION			
NO	DESCRIPTION	BY	DATE
1	△ SUBMISSION: 90% CD	KE	09/07/11
2	△ FINALS	TM	11/07/11
3	△ FINALS-REV1	TM	08/17/12

SHEET TITLE:
TITLE SHEET

SHEET NUMBER:
T-1

TABLE OF CONTENTS

1.0 GENERAL REQUIREMENTS

1.1 PURPOSE AND INTENT

1.2 CONFLICTS

1.3 CLEANING

1.4 CODES

1.5 LICENSING

1.6 OSHA

1.7 PHOTOS

1.8 BUILDING PERMITS

1.9 ZONING REGULATIONS & CONDITIONAL USE PERMITS

1.10 FAA PERMIT AND TOWER LIGHTING

1.11 TOWER SECURITY

1.12 SITE CONTROL

2.0 SITE PREPARATION

2.1 SCOPE OF WORK

2.2 PRODUCT AND MATERIALS

3.0 EARTHWORK

3.1 SCOPE OF WORK

3.2 QUALITY ASSURANCE

3.3 PRODUCTS AND MATERIALS

3.4 CLEARING AND GRUBBING

3.5 STRIPPING

3.6 COMMON EXCAVATION

3.7 EMBANKMENT

3.8 SITE GRADING

3.9 SUBGRADE PREPARATION

3.10 GEOTEXTILE FABRIC

3.11 GRAVEL SURFACING

4.0 TRENCHING

4.1 MATERIALS

4.2 PIPE DETECTION AND IDENTIFICATION

4.3 TRENCH EXCAVATION

4.4 TRENCH PROTECTION

4.5 BACKFILLING

4.6 COMPACTION

5.0 CHAIN LINK FENCES AND GATES

5.1 GENERAL

5.2 PRODUCTS MD MATERIALS

6.0 LANDSCAPING

7.0 CONCRETE FORMWORK

8.0 CONCRETE REINFORCEMENT

9.0 CAST-IN PLACE CONCRETE

10.0 STRUCTURAL STEEL

11.0 GROUNDING

COMPLY WITH THESE STANDARDS UNLESS OTHERWISE REQUIRED BY APPLICABLE CODES

1.0 CONSTRUCTION TO CONFORM TO SPRINT NEXTEL INTEGRATED CONSTRUCTION STANDARDS

1.1 PURPOSE AND INTENT

A. THE DRAWINGS AND SPECIFICATIONS ARE INTENDED TO BE FULLY EXPLANATORY AND SUPPLEMENTARY. HOWEVER, SHOULD ANYTHING BE SHOWN, INDICATED OR SPECIFIED ON ONE AND NOT THE OTHER, IT SHALL BE DONE THE SAME AS IF SHOWN, INDICATED OR SPECIFIED IN BOTH. SHOULD THERE BE ANY DISCREPANCIES BETWEEN REQUIREMENTS SHOWN IN BOTH, THE MORE STRINGENT REQUIREMENTS SHALL APPLY.

B. THE INTENTION OR THE DOCUMENTS IS TO INCLUDE ALL LABOR AND MATERIALS REASONABLY NECESSARY FOR THE PROPER EXECUTION AND COMPLETION OF THE WORK AS STIPULATED IN THE CONTRACT.

C. THE PURPOSE OF THE SPRINT WIRELESS CONSTRUCTION SPECIFICATIONS IS TO INTERPRET THE INTENT OF THE DRAWINGS AND TO DESIGNATE THE METHOD OF THE PROCEDURE, TYPE AND QUALITY OF MATERIALS REQUIRED TO COMPLETE THE WORK.

1.2 CONFLICTS

A. VERIFY ALL MEASUREMENTS AT THE SITE BEFORE ORDERING MATERIAL OR DOING ANY WORK. NO EXTRA CHARGE OR COMPENSATION WILL BE ALLOWED DUE TO DIFFERENCES BETWEEN ACTUAL DIMENSIONS OR DIMENSIONS SHOWN ON PLANS. SUBMIT NOTICE OF ANY DISCREPANCY IN DIMENSIONS OR OTHERWISE TO SPRINT WIRELESS FOR RESOLUTION BEFORE PROCEEDING WITH THE WORK.

B. NO PLEA OF IGNORANCE OF CONDITIONS THAT EXIST OR OF DIFFICULTIES OF CONDITIONS THAT MAY BE ENCOUNTERED, OR OF ANY OTHER RELEVANT MATTER CONCERNING THE EXECUTION OF THE WORK WILL BE ACCEPTED AS AN EXCUSE FOR ANY FAILURE OR OMISSION ON THE PART OF THE CONTRACTOR TO FULFILL EVERY DETAIL OF ALL THE REQUIREMENTS OF THE CONSTRUCTION DOCUMENTS GOVERNING THE WORK.

1.3 CLEANING

KEEP THE SITE FREE FROM ACCUMULATION OF WASTE AND RUBBISH CAUSED BY EMPLOYEES AT THE COMPLETION OF THE WORK. REMOVE ALL WASTE AND NON-CONSTRUCTION MATERIAL INCLUDING ALL CONTRACTOR TOOLS, SCAFFOLDING AND SURPLUS MATERIAL AND LEAVE SITE CLEAN AND READY FOR USE.

1.4 CODES

CONTRACTOR SHALL BE RESPONSIBLE FOR FOLLOWING ALL LAWS, REGULATIONS AND RULES PROMULGATED BY FEDERAL STATE AND LOCAL AUTHORITIES WITH JURISDICTION OVER THE SITE. THIS RESPONSIBILITY IS IN EFFECT REGARDLESS OF WHETHER THE LAW, ORDINANCE, REGULATION OR RULE IS MENTIONED IN THESE SPECIFICATIONS.

1.5 LICENSING

HAVE AND MAINTAIN A VALID CONTRACTORS LICENSE FOR THE LOCATION IN WHICH THE WORK IS TO BE PERFORMED. FOR JURISDICTIONS THAT LICENSE INDIVIDUAL TRADES, THE TRADESMAN OR SUBCONTRACTORS PERFORMING THOSE TRADES SHALL BE LICENSED. RESEARCH AND COMPLY WITH LICENSING LAWS, PAY LICENSE FEES, AND SELECT AND INFORM SUBCONTRACTORS REGARDING THESE LAWS.

1.6 OSHA

FOLLOW ALL APPLICABLE RULES AND REGULATIONS OF THE OCCUPATIONAL SAFETY AND HEALTH ADMINISTRATIONS, AND STATE LAWS BASED IN THE FEDERAL OCCUPATIONAL SAFETY AND HEALTH ACT. THESE REGULATIONS INCLUDE BUT ARE NOT LIMITED TO REGULATIONS DEALING WITH TOWER CONSTRUCTION AND SAFETY, EXCAVATIONS AND TRENCHING, AND WORK IN CONFINED SPACES. ENSURE THAT EMPLOYEES AND SUBCONTRACTORS WEAR HARD HATS AT ALL TIMES DURING CONSTRUCTION.

1.7 PHOTOS

PROVIDE PHOTOGRAPHIC EVIDENCE OF ALL FOUNDATION INSTALLATION, GROUNDING AND TRENCHING AFTER PLACEMENT OF UTILITIES PRIOR TO BACKFILL.

1.8 BUILDING PERMITS

SPRINT WIRELESS WILL SUBMIT CONSTRUCTION DOCUMENTS TO THE JURISDICTIONAL AUTHORITY FOR PLAN CHECK AND REVIEW. CONTRACTOR WILL SUBMIT LICENSING AND WORKMAN'S COMPENSATION INFORMATION TO THE JURISDICTION AS REQUIRED TO OBTAIN THE BUILDING PERMIT. CONTRACTOR SHALL COORDINATE AND SCHEDULE REQUIRED INSPECTIONS AND POST REQUIRED PERMITS AT THE JOB SITE. COMPLY WITH SPECIFIC PROJECT-RELATED REQUESTS AND SUGGESTIONS MADE BY BUILDING INSPECTOR AND INFORM CONSTRUCTION MANAGER OF ANY SUCH WORK THAT MAY BE BEYOND THE SCOPE OF THE CONTRACT OR DEVIATE FROM THE CONSTRUCTION DOCUMENTS. SPRINT WIRELESS WILL REIMBURSE THE CONTRACTOR FOR FEES FOR PLAN REVIEW, BUILDING PERMIT, CONNECTIONS AND INSPECTION.

1.9 ZONING REGULATIONS AND CONDITIONAL USE PERMITS

SPRINT WIRELESS WILL SUBMIT FOR AND OBTAIN ALL ZONING AND CONDITIONAL USE PERMITS. SOME USE PERMITS MAY HAVE SPECIFIC REQUIREMENTS RELATED TO THE CONSTRUCTION SUCH AS NOISE REGULATIONS, HOURS OF WORK, ACCESS LIMITATIONS, ETC. THE CONSTRUCTION MANAGER WILL INFORM THE CONTRACTOR OF THESE REQUIREMENTS AT THE PRE-BID MEETING OR AS SHOWN IN CONSTRUCTION DOCUMENTS.

1.10 FM PERMIT AND TOWER LIGHTING

REFER TO CONSTRUCTION DOCUMENTS AND CONSTRUCTION MANAGER FOR FAA AND STATE LIGHTING REQUIREMENTS. CONTRACTOR SHALL PROVIDE TEMPORARY FM APPROVED LIGHTING UNTIL PERMANENT LIGHTING IS OPERATIONAL

1.11 TOWER SECURITY

TOWER MUST BE FENCED, TEMPORARILY OR PERMANENTLY WITHIN 24 HOURS OF ERECTION. DO NOT ALLOW THE GATE ACCESSING THE TOWER AREA TO REMAIN OPEN OR UNATTENDED AT ANY TIME FOR ANY REASON. KEEP THE GATE CLOSED AND LOCKED WHEN NOT IN USE.

1.12 SITE CONTROL

A. THE CONTRACTOR IS COMPLETELY RESPONSIBLE FOR CONTAINMENT OF SEDIMENT AND CONTROL OF EROSION AT THE SITE. ANY DAMAGE TO ADJACENT OR DOWNSTREAM PROPERTIES WILL BE CORRECTED BY THE CONTRACTOR AT NO EXPENSE TO SPRINT WIRELESS.

B. THE CONTRACTOR IS TO MAINTAIN ADEQUATE DRAINAGE AT ALL TIMES. DO NOT ALLOW WATER TO STAND OR POND. ANY DAMAGE TO STRUCTURES OR WORK ON THE SITE CAUSED BY INADEQUATE MAINTENANCE OF DRAINAGE PROVISIONS WILL BE THE RESPONSIBILITY OF THE CONTRACTOR AND ANY COST ASSOCIATED WITH REPAIRS FOR SUCH DAMAGE WILL BE AT THE CONTRACTOR'S EXPENSE.

C. ALL WASTE MATERIAL SHALL BE PROPERLY DISPOSED OF OFF-SITE OR AS DIRECTED BY THE CONSTRUCTION MANAGER AND IN ACCORDANCE WITH JURISDICTIONAL AUTHORITIES.

2.0 SITE PREPARATION

2.1 SCOPE OF WORK INCLUDES:

A. PROTECTION OF EXISTING TREES, VEGETATION AND LANDSCAPING MATERIALS WHICH MIGHT BE DAMAGED BY CONSTRUCTION ACTIVITIES.

B. TRIMMING OF EXISTING TREES AND VEGETATION AS REQUIRED FOR PROTECTION DURING CONSTRUCTION ACTIVITIES.

C. CLEARING AND GRUBBING OF STUMPS, VEGETATION, DEBRIS, RUBBISH, DESIGNATED TREES, AND SITE IMPROVEMENTS.

D. TOPSOIL STRIPPING AND STOCKPILING.

E. TEMPORARY EROSION CONTROL, SILTATION CONTROL AND DUST CONTROL CONFORMING TO LOCAL REQUIREMENTS AS APPLICABLE.

F. TEMPORARY PROTECTION OF ADJACENT PROPERTY, STRUCTURES, BENCHMARKS AND MONUMENTS.

G. PROTECTION AND TEMPORARY RELOCATION, STORAGE AND RE-INSTALLATION OF DUSTING FENCING AND OTHER SITE IMPROVEMENTS SCHEDULED FOR REUSE.

H. REMOVAL AND LEGAL DISPOSAL OF CLEARED MATERIALS.

2.2 PRODUCTS AND MATERIALS (AS APPROVED BY CONSTRUCTION MANAGER OR AS NOTED III CONSTRUCTION DOCUMENTS.)

A. MATERIALS USED FOR TREE PROTECTION, EROSION CONTROL, SILTATION CONTROL AND DUST CONTROL AS SUITABLE FOR SPECIFIC SITE CONDITIONS.

3.0 EARTH WORK

3.1 SCOPE OF WORK INCLUDES:

A. EXCAVATION, TRENCHING, FILLING, COMPACTION, AND GRADING FOR STRUCTURES, SITE IMPROVEMENTS AND UTILITIES.

B. MATERIALS FOR SUB-BASE DRAINAGE FILL, FILL, BACKFILL AND GRAVEL FOR SLABS, PAVEMENTS AND IMPROVEMENTS.

C. ROCK EXCAVATION WITHOUT BLASTING.

D. SUPPLY OF ADDITIONAL MATERIALS FROM OFFSITE AS REQUIRED.

E. REMOVAL AND LEGAL DISPOSAL OF EXCAVATED MATERIALS AS REQUIRED

3.2 QUALITY ASSURANCE

A. COMPACTION:

1. UNDER STRUCTURES, BUILDING SLABS, PAVEMENTS AND WALKWAYS WILL OBTAIN A 95 PERCENT COMPACTION AT A MAXIMUM DRY DENSITY AS DETERMINED BY ASTM 0-1557 OR WITHIN PLUS OR MINUS 3 PERCENT OF OPTIMUM MOISTURE.

B. GRADING TOLERANCES OUTSIDE BUILDING CODES:

1. LAWNS, UNPAVED AREAS AND WALKS PLUS OR MINUS 1 INCH.

2. UNDER PAVEMENTS PLUS OR MINUS 1/2 INCH.

C. GRADING TOLERANCE FOR FILL UNDER ALL CONCRETE APPLICATIONS: PLUS OR MINUS 1/2 INCH MEASURED WITH 10 FOOT STRAIGHTEDGE.

3.3 PRODUCTS AND MATERIALS (AS APPROVED BY CONSTRUCTION MANAGER OR AS NOTED IN CONSTRUCTION DOCUMENTS.)

A. SUBBASE MATERIAL GRADED MIXTURE OF NATURAL OR CRUSHED GRAVEL, CRUSHED STONE OR SLAG, AND NATURAL SAND.

B. WASHED MATERIAL EVENLY GRADED MIXTURE OF CRUSHED STONE OR GRAVEL WITH 95 PERCENT PASSING A 1 1/2 INCH SIEVE.

C. GRADING MATERIAL WILL CONSIST OF: SATISFACTORY NATIVE OR IMPORTED SOILMATERIALS FREE OF CLAY, ROCK OR GRAVEL NOT LARGER THAN 2 INCHES IN ANY DIMENSION, DEBRIS, WASTE, FROZEN MATERIALS AND OTHER UNSUITABLE MATERIALS WILL NOT BE ALLOWED FOR USE. IMPORTED MATERIALS SHALL HAVE A CLAY CONTENT NO MORE THAN 5 PERCENT.

D. BACKFILL MATERIALS WILL CONSIST OF: SATISFACTORY NON-COHESIVE NATIVE OR IMPORTED SOIL MATERIALS FREE OF CLAY, ROCK OR GRAVEL NOT LARGER THAN 4 INCHES IN ANY DIMENSION, DEBRIS, WASTE, FROZEN MATERIALS, AND OTHER UNSUITABLE MATERIALS. IMPORTED MATERIAL SHALL HAVE A CLAY CONTENT OF NO MORE THAN 5 PERCENT.

E. GRAVEL MATERIAL EVENLY GRADED MIXTURE OF CRUSHED STONE OR GRAVEL WITH 95 PERCENT PASSING A 1 1/2 INCH SIEVE.

F. GEOTEXTILE FABRIC: AS PER CONSTRUCTION DOCUMENTS.

3.4 CLEARING AND GRUBBING REMOVE ALL VEGETATION AND MATERIALS AS REQUIRED. REMOVE STUMPS COMPLETELY UNDER FOUNDATIONS AND ROADWAY. DISPOSE OF CLEARING AND GRUBBING OFF-SITE, OR IN AN ON-SITE LOCATION APPROVED BY CONSTRUCTION MANAGER.

3.5 STRIPPING

STRIP NOT LESS THAN 3 INCHES OF SOD AND TOPSOIL FROM AREAS THAT WILL UNDERLAY GRAVEL PAVEMENT, NEW STRUCTURES OR NEW EMBANKMENTS. STOCKPILE STRIPPING ON-SITE FOR RE-USE IN FINAL LANDSCAPING.

3.6 COMMON EXCAVATION

1. EXCAVATE TO DEPTH, LINES AND GRADES SHOWN ON THE PLANS OR AS OTHERWISE SPECIFIED.

2. TEMPORARILY STOCKPILE ON-SITE EXCAVATION AT AN APPROVED LOCATION WITHIN THE WORK AREA UNTIL SITE GRADING IS COMPLETE STOCKPILE SHALL NOT EXCEED 15 FEET IN HEIGHT.

3. LEGALLY DISPOSE OF EXCESS COMMON EXCAVATION OFF-SITE.

PREPARED FOR:



1 INTERNATIONAL BOULEVARD
SUITE #800
MAHWAH, N.J. 07495

CONSULTANT:



POWDER RIVER
Development Services, LLC
100 E. SHENANGO STREET
SHARPSVILLE, PA 16150
724.962.5999
www.powderriverdev.com
PRDS PROJ.NO. 1181-081911

SITE NAME:
**SPRING LAKE
FIRE STATION #43**

SITE NUMBER:
SA13XC135

SITE ADDRESS:
2059 W. BITTERS ROAD
SAN ANTONIO, TX 78248

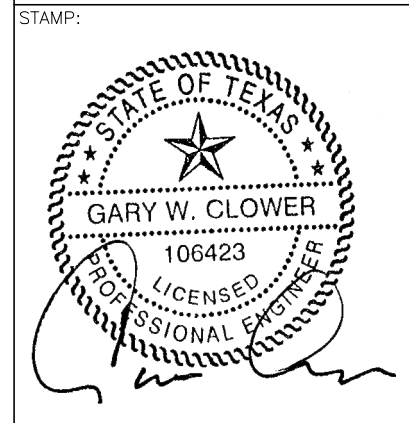

DRAWN BY:	KE		
APPROVED BY:	G.W.C.		
DATE DRAWN:	09/07/11		
REVISION			
NO	DESCRIPTION	BY	DATE
△	SUBMISSION: 90% CD	KE	09/07/11
△	FINALS	TM	11/07/11
△	FINALS-REV1	TM	08/17/12

SHEET TITLE:
GENERAL NOTES

SHEET NUMBER:
T-2

3.7 EMBANKMENT

- A. CONSTRUCT EMBANKMENT TO THE LINES AND GRADE SHOWN ON THE DRAWINGS.
B. CONSTRUCT EMBANKMENT FROM ON-SITE EXCAVATION MATERIALS WHEN SUITABLE USE IMPORTED BACKFILL ONLY AFTER AVAILABLE ON-SITE EXCAVATION MATERIALS HAVE BEEN USED.
C. CONSTRUCT IN LIFTS OF NOT MORE THAN 12 INCHES IN LOOSE DEPTH. THE FULL WIDTH OF THE CROSS SECTION SHALL BE BROUGHT UP UNIFORMLY.
D. MATERIAL SHALL NOT BE PLACED IN LAYERS AND SHALL BE NEAR OPTIMUM MOISTURE CONTENT BEFORE ROLLING TO OBTAIN THE PRESCRIBED COMPACTION. WETTING DR DRYING OF THE MATERIAL AND MANIPULATION TO SECURE A UNIFORM MOISTURE CONTENT THROUGHOUT THE LAYER MAY BE REQUIRED. SUCH OPERATIONS SHALL BE INCLUDED IN THE APPROPRIATE BID ITEM. SHOULD THE MATERIAL BE TOO WET TO PERMIT PROPER COMPACTION, IT IS THE CONTRACTOR'S RESPONSIBILITY TO UTILIZE MATERIAL WITH AN ACCEPTABLE MOISTURE CONTENT.
E. DO NOT PLACE FROZEN MATERIAL IN THE EMBANKMENT AND DO NOT PLACE EMBANKMENT MATERIAL UPON FROZEN MATERIAL.
F. CONTRACTOR SHALL BE RESPONSIBLE FOR THE STABILITY OF EMBANKMENTS AND THE REPLACEMENT OF ANY PORTION WHICH HAS BECOME DISPLACED DUE TO THE CONTRACTORS OPERATIONS.
G. START LAYERS IN THE DEEPEST PORTION OF THE FILL, AND AS PLACEMENT PROGRESSES, CONSTRUCT LAYERS APPROXIMATELY PARALLEL TO THE FINISHED GRADE LINE.
H. ROUTE EQUIPMENT, BOTH LOADED AND EMPTY, OVER THE FULL WIDTH OF EMBANKMENT TO ENSURE UNIFORMITY OF MATERIAL PLACEMENT.
I. COMPACT EMBANKMENT UNDERLYING NEW GRAVEL PAVING FLOOR SLABS AND STRUCTURES TO A 95 PERCENT COMPACTION AT A MAXIMUM DRY DENSITY AS DETERMINED BY ASTM 0-1557 OR WITHIN PLUS OR MINUS 3 PERCENT OF OPTIMUM MOISTURE CONTENT. COMPACT NON-STRUCTURAL AREA EMBANKMENTS TO A MINIMUM OF 90 % OF ASTM 0-1557.

3.8 SITE GRADING

- A. USING ON-SITE EXCAVATION MATERIALS SHAPE, TRIM, FINISH AND COMPACT SURFACE AREAS TO CONFORM TO THE LINES, GRADES AND CROSS SECTIONS SHOWN ON THE DRAWINGS OR AS DESIGNATED BY THE CONSTRUCTION MANAGER.
B. GRADE SURFACES TO DRAIN AND ELIMINATE ANY PONDING OR EROSION.
C. ELIMINATE WHEEL RUTS BY REGRADING.
D. COMPACT AREAS UNDERLYING NEW GRAVEL PAVING, FLOOR SLABS AND STRUCTURES TO A 95 PERCENT COMPACTION AT A MAXIMUM DRY DENSITY AS DETERMINED BY ASTM D-1551 OR WITHIN PLUS OR MINUS 3 PERCENT OF OPTIMUM MOISTURE CONTENT.
E. CONSTRUCT FINISHED SURFACE OF SITE GRADING AREAS WITHIN ONE INCH FROM SPECIFIED GRADE

3.9 SUBGRADE PREPARATION

- A. SHAPE TOP OF SUBGRADE TO THE LINES AND GRADES SHOWN ON THE DRAWINGS.
B. MAINTAIN TOP OF SUBGRADE TO A FREE-DRAINING CONDITION.
C. DO NOT STOCKPILE MATERIALS ON TOP OF SUBGRADE UNLESS AUTHORIZED BY CONSTRUCTION MANAGER.
D. COMPACT THE TOP 12 INCHES OF SUBGRADE TO A 95% COMPACTION AT A MAXIMUM DRY DENSITY AS DETERMINED BY ASTM 0-1557 OR WITHIN PLUS OR MINUS 3 PERCENT OF OPTIMUM MOISTURE CONTENT.
E. CONSTRUCT TOP OF SUBGRADE WITHIN ONE INCH OF ESTABLISHED GRADE AND CROSS-SECTION.

3.10 GEOTEXTILE FABRIC

- A. LAY GEOTEXTILE FABRIC OVER COMPACTED SUBGRADE AS PER CONSTRUCTION DOCUMENTS IN THE COMPOUND AREA AND UNDER LENGTH OF ROAD (WHEN REQUIRED). LAP ALL JOINTS TO A MINIMUM OF 36 INCHES.

3.11 GRAVEL SURFACING

- A. CONSTRUCT GRAVEL SURFACING AREAS USING CRUSHED AGGREGATE BASE AND FINISH COURSES AS SPECIFIED BY CONSTRUCTION MANAGER OR CONSTRUCTION DOCUMENTS.
B. SPREAD GRAVEL AND RAKE TO OBTAIN A UNIFORM SURFACE AREA.

4.0 TRENCHING

- CALL LOCAL UNDERGROUND UTILITY LOCATING SERVICE BEFORE ANY EXCAVATION OR TRENCHING.

4.1 MATERIALS

FILL MATERIAL SHALL BE OBTAINED, WHEN POSSIBLE FROM MATERIALS EXCAVATED FROM TRENCHES. ON-SITE STRUCTURAL FILL SAND OR SLURRY SHALL BE APPROVED BY THE CONSTRUCTION MANAGER AND SHALL CONFORM TO LOCAL GOVERNING JURISDICTIONS AND UTILITY COMPANY REQUIREMENTS. THE FILL MATERIAL SHALL CONTAIN NO ORGANIC MATERIAL OR ROCKS, NOR SHALL CONTAIN OBJECTIONABLE MATERIALS AND/OR MATERIALS DESIGNATED AS HAZARDOUS OR INDUSTRIAL BY THE ENVIRONMENTAL PROTECTION AGENCY (EPA). THE FILL MATERIAL SHALL CONTAIN FINES SUFFICIENT TO FILL ALL VOIDS IN THE MATERIAL COMPACTION OF BACKFILL OR BORROW SOIL SHALL BE PLACED IN 12 INCH LOOSE LIFTS WHEN UTILIZING HEAVY COMPACTION EQUIPMENT OR 6 INCH LOOSE LIFTS WHEN UTILIZING HAND OPERATED TAMPERS.

4.2 PIPE DETECTION AND IDENTIFICATION

- A. UTILIZING WARNING TAPE: ALL ELECTRIC SERVICE TRENCHES SHALL BE MARKED WITH WARNING TAPE.

4.3 TRENCH EXCAVATION

- A. DIG TRENCH TO LINES AND GRADES SHOWN ON THE PLANS OR AS DIRECTED BY CONSTRUCTION MANAGER.
B. TRENCH LENGTH SHALL BE SUFFICIENT TO ALLOW FOR SATISFACTORY CONSTRUCTION AND INSPECTION OF THE PROJECT WITHOUT ENDANGERING OTHER CONSTRUCTION WORK OR ADJACENT FACILITIES.
C. DISPOSE OF EXCESS AND UNSUITABLE EXCAVATION MATERIAL PROPERLY, AS DIRECTED BY CONSTRUCTION MANAGER.
D. USE HAND METHODS FOR EXCAVATION THAT CANNOT BE ACCOMPLISHED WITHOUT ENDANGERING EXISTING OR NEW STRUCTURES OR OTHER FACILITIES.

4.4 TRENCH PROTECTION

- A. PROVIDE MATERIALS, LABOR AND EQUIPMENT NECESSARY TO PROTECT TRENCHES AT ALL TIMES.
B. SHEETING AND BRACING: MEET OR EXCEED OSHA REQUIREMENTS.

4.5 BACKFILLING

- A. NOTIFY THE CONSTRUCTION MANAGER AT LEAST 24 HOURS IN ADVANCE OF BACKFILLING.
B. BACKFILL TRENCH WITH LIFTS UP TO 12 INCHES, LOOSE MEASURE.
C. PROTECT CONDUIT FROM LATERAL MOVEMENT, DAMAGE FROM IMPACT OR UNBALANCED LOADING TO AVOID DISPLACEMENT OF CONDUIT AND/OR STRUCTURES. DO NOT FREE FALL BACKFILL INTO TRENCH UNTIL AT LEAST 12 INCHES OF COVER IS OVER THE CONDUIT.

4.6 COMPACTION

- A. COMPACT BACKFILL TO A 95 PERCENT COMPACTION AT A MAXIMUM DRY DENSITY AS DETERMINED BY ASTM 0-1557 OR WITHIN PLUS OR MINUS 3 PERCENT OF OPTIMUM MOISTURE CONTENT.
B. IF REQUIRED COMPACTION DENSITY HAS NOT BEEN OBTAINED, REMOVE THE BACKFILL FROM THE TRENCH OR STRUCTURE, REPLACE WITH APPROVED BACKFILL AND RECOMPACT AS SPECIFIED.
C. ANY SUBSEQUENT SETTLEMENT OF TRENCH OR STRUCTURE BACKFILL DURING MAINTENANCE PERIOD SHALL BE CONSIDERED THE RESULT OF IMPROPER COMPACTION AND SHALL BE PROMPTLY CORRECTED.

5.0 CHAIN LINK FENCES AND GATES

5.1 GENERAL

- A. PROVIDE CHAIN LINK FENCES AND GATES AS COMPLETE UNITS BY A SINGLE SUPPLY SOURCE INCLUDING NECESSARY ERECTION ACCESSORIES, FITTINGS AND FASTENERS.

5.2 PRODUCTS AND MATERIALS (AS APPROVED BY CONSTRUCTION MANAGER OR AS WITHIN CONSTRUCTION DOCUMENTS)

- A. COMPOUND FABRIC 84 INCHES HIGH AND OVER WITH 2-INCH MESH SHALL BE KNUCKLED AT ONE SELVAGE AND TWISTED AT THE OTHER.
B. STEEL FABRIC:
COMPLY WITH CHAIN LINK FENCE MANUFACTURERS INSTITUTE (CLFMI) PRODUCT MANUAL. FURNISH ONE PIECE OF FABRIC WIDTHS. WIRE SIZE INCLUDES ZINC OR ALUMINUM COATING.
1. SIZE: 2-INCH MESH 9 GAUGE (D.148-INCH DIAMETER) WIRE.
2. GALVANIZED STEEL FINISH: ASTM A 392. CLASS 2. WITH A MINIMUM 2.0 OZ. ZINC PER SQ. FT. OF UNCOATED WIRE SURFACE.
C. FRAMEWORK AND ACCESSORIES:
1. GENERAL REQUIREMENTS: EXCEPT AS INDICATED OTHERWISE CONFORM TO THE CHAIN LINK FENCE MANUFACTURERS INSTITUTE (CLFMI) PRODUCT MANUAL INDUSTRIAL STEEL GUIDE FOR FENCE RAILS, POSTS, GATES AND ACCESSORIES INCLUDING TABLE II.
2. STRENGTH REQUIREMENTS FOR POSTS AND RAILS CONFORMING TO ASTM F 669.
3. TYPE 1 PIPE HOT-DIPPED GALVANIZED STEEL PIPE CONFORMING TO ASTM F 1083. PLANE ENDS, STANDARD WEIGHT (SCHEDULE 40) WITH NOT LESS THAN 18 OZ. ZINC PER SQ. FT. OF SURFACE AREA COATED.
4. FILLINGS: COMPLY WITH ASTM F 526 MILL FINISHED ALUMINUM OR GALVANIZED IRON STEEL TO COMPLY WITH MANUFACTURER'S REQUIREMENTS.
5. TOP RAIL MANUFACTURERS LONGEST LENGTHS, WITH EXPANSION TYPE COUPLINGS, APPROXIMATELY 6 INCHES LONG, FOR EACH JOINT. PROVIDE MEANS FOR ATTACHING TOP RAIL SECURELY TO EACH GATE CORNER, PULL AND END POST.
D. GALVANIZED STEEL 11/4 INCH NPS (1.66 INCH OD) TYPE I OR II STEEL PIPE OR 1.625 INCH x 1.25 INCH ROLL-FORMED C SECTIONS WEIGHING 1.35 LBS. PER FT.
E. SWING GATES:
COMPLY WITH ASTM F 9000. PROVIDE HARDWARE AND ACCESSORIES FOR EACH GATE. GALVANIZED PER ASTM A 153, AND IN ACCORDANCE WITH THE FOLLOWING:
1. HINGES: NON LIFT-OFF TYPE. OFFSET TO PERMIT ISO DEG. GATE OPENING.
2. LATCH: MTS MULTI-LOCKING DEVICE MT-C6477 OR APPROVED EQUAL.
3. KEEPER: PROVIDE KEEPER FOR VEHICLE GATES, WHICH AUTOMATICALLY ENGAGES GATE LEAF AND HOLDS IT IN OPEN POSITION UNTIL MANUALLY RELEASED.

- F. CONCRETE:
PROVIDE CONCRETE CONSISTING OF PORTLAND CEMENT, ASTM C 150, AGGREGATES ASTM C 33, AND CLEAN WATER. MIX MATERIALS TO OBTAIN CONCRETE WITH A MINIMUM OF 28-DAY COMPRESSIVE STRENGTH OF 3000 PSI.

6.0 LANDSCAPING

- A. FURNISH, INSTALL AND MAINTAIN LANDSCAPE WORK AS SHOWN AND OR REQUIRED WITHIN THE CONSTRUCTION DOCUMENTS OR AS SPECIFIED IN THE SPRINT WIRELESS CONSTRUCTION SPECIFICATIONS.

7.0 CONCRETE FORMWORK

- A. FORMS: SMOOTH AND FREE OF SURFACE IRREGULARITIES. UTILIZE FORM RELEASE AGENTS.
B. CHAMFER: EXPOSED EDGES OF ALL TOWER FOUNDATIONS SHALL RECEIVE A 3/4" BY 3/4" 45 DEGREE CHAMFER. OTHER EXPOSED EDGES SHALL RECEIVE A TOOLED RADIUS FINISH.
C. UPON COMPLETION, REMOVE ALL FORMS, INCLUDING THOSE CONCEALED OR BURIED.
D. REFER TO STRUCTURAL DRAWINGS FOR ADDITIONAL REQUIREMENTS.

8.0 CONCRETE REINFORCEMENT

REFER TO STRUCTURAL DRAWINGS FOR ALL REQUIREMENTS.

9.0 CAST IN PLACE CONCRETE

- FOR STRUCTURAL CONCRETE (FOOTINGS, FOUNDATIONS, ETC.), REFER TO STRUCTURAL DRAWINGS FOR REQUIREMENTS. FOR ANY MISCELLANEOUS CONCRETE, REFER TO SPECIFICATION BOOK OR OBTAIN REQUIREMENTS FROM CONSTRUCTION MANAGER.
A. ALL CONCRETE SHALL COMPLY WITH ASTM C94 UNLESS NOTED OTHERWISE.
B. MINIMUM COMPRESSIVE STRENGTH (F'C) AT 28 OATS: 4000 PSI FOR TOWER FOUNDATION AND 3500 PSI FOR ALL OTHER CONCRETE UNLESS SPECIFIED IN CONSTRUCTION DOCUMENTS.
C. AIR ENTRAINMENT: PROVIDE 4 TO 8% AIR ENTRAINMENT FOR ALL CONCRETE SUBJECT TO FREEZE-THAW CYCLE.
D. CONCRETE TESTING: ALL FOUNDATION CONCRETE SHALL BE TESTED BY AN INDEPENDENT TESTING AGENCY APPROVED BY THE CONSTRUCTION MANAGER. ALL STRUCTURAL TOWER FOUNDATION CONCRETE MUST BE TESTED. EQUIPMENT OR BUILDING PADS ARE NOT REQUIRED TO BE TESTED, UNLESS OTHERWISE NOTED BY CONSTRUCTION MANAGER. PROVIDE A MINIMUM OF 5 CYLINDERS (2-7-DAY, 2-28-DAY, 1-SPARE) FOR EACH OATS POUR, OR FOR EVERY 50 YARDS PLACED, WHICHEVER IS GREATER. ADDITIONAL TESTS OR CYLINDERS MAY BE REQUIRED BY CONSTRUCTION MANAGER. A SLUMP, AIR, AND TEMPERATURE TEST SHALL BE PERFORMED FOR EACH SET OF CYLINDERS CAST. PREFERABLY, TESTS SHALL BE PERFORMED AT THE LOCATION OF ANCHOR BOLTS (PIERS - FOR MAT & PIERS, CAISSONS - TOP 1/3 OF CAISSON). TESTS SHALL ALSO BE REQUIRED FOR CONCRETE CONSIDERED BEING LESS THAN DESIRABLE BY CONCRETE SPECIFICATION STANDARDS. THE TESTING AGENCY HAS THE AUTHORITY TO NOT ACCEPT CONCRETE MEETING THESE SPECIFICATIONS FOR SPRINT WIRELESS. THE CONTRACTOR IS RESPONSIBLE FOR ANY CONCRETE NOT MEETING THESE STANDARDS. THE CONTRACTOR IS RESPONSIBLE FOR COORDINATION OF THE TESTING AGENCY A MINIMUM OF 24 HOURS IN ADVANCE OF EACH FOUNDATION POUR. TEST REPORTS SHALL BE FORWARDED TO SPRINT CONSTRUCTION MANAGER WITHIN 24 HOURS OF LAB TEST.
E. VIBRATE ALL CONCRETE USING SUFFICIENT HIGH FREQUENCY LOW AMPLITUDE MECHANICAL IMMERSION TYPE VIBRATORS. INSERT VIBRATORS IN CONCRETE AT REGULAR INTERVALS AND OVER ENTIRE SURFACE TO SOLIDLY FILL CONCRETE MECHANICAL IMMERSION TYPE VIBRATORS. INSERT VIBRATORS IN CONCRETE AT REGULAR INTERVALS AND OVER ENTIRE SURFACE TO SOLIDLY FILL CONCRETE AROUND AND BETWEEN REINFORCEMENT BARS AND INTO CORNERS AND IRREGULARITIES. VIBRATE THOROUGHLY THROUGH EACH LIFT TO THE PREVIOUS LIFE REVERBERATION AS LATE AS THE RUNNING VIBRATOR WILL SINK THROUGH UPPER LAYERS OF ITS WEIGHT IS RECOMMENDED. DISCONTINUE VIBRATION WHEN RISING ENTRAPPED AIR BUBBLES STOP BREAKING THE LEVELING SURFACE. DO NOT OVER VIBRATE AS THIS MAY CAUSE SEGREGATION.
F. FINISHING EXPOSED CONCRETE SURFACES:
1. THESE PROVISIONS APPLY TO ALL EXPOSED AND ALL FORMED CONCRETE, EXTERIOR OR INTERIOR. UNLESS SPECIFICALLY DETAILED OTHERWISE, PERFORM PROCEDURES PRIOR TO APPLICATION OF ANY CURING COMPOUNDS.
2. ALL SURFACES: THOROUGHLY CLEAN OFF ALL STAINS, SPATTER AND LOOSE MATERIAL.
3. FINS, RIDGES AND HIGH SPOTS: HONE SMOOTH WITH ABRASIVE POWER GRINDERS WHILE CONCRETE IS GREEN, IMMEDIATELY AFTER FORM REMOVAL.
4. FORM TIE HOLES AND DEEP DEPRESSIONS: FLUSH THOROUGHLY WITH CLEAN WATER AND TAMP TO OVERFULL WITH DRYPACK. CURE 10 DAYS AND HONE FLUSH AND SMOOTH.
5. ROCK POCKETS, HONEYCOMB, SAND STREAKS, DEBRIS AND VOIDS: CUT OUT AT LEAST 1 INCH DEEP WITH SIDES PERPENDICULAR TO SURFACE. FLUSH THOROUGHLY WITH CLEAN WATER, COAT SURFACE WITH NEAT CEMENT PASTE AND TAMP TO OVERFULL WITH DRYPACK IN AT LEAST TWO LAYERS. CURE FOR 10 DAYS AND HONE FLUSHED AND SMOOTH.
G. CONTRACTOR SHALL VERIFY ALL SIZES AND LOCATIONS OF ALL ELECTRICAL OPENINGS AND EQUIPMENT/BUILDING PADS WITH THE ELECTRICAL DRAWINGS AND SHOP DRAWINGS. IT SHALL BE THE RESPONSIBILITY OF THE CONTRACTOR TO PROVIDE ALL OPENINGS AND SLEEVES FOR PROPER DISTRIBUTION FOR ALL UTILITIES.
CONTRACTOR SHALL REFER TO DRAWINGS OF OTHER TRADES AND VENDOR DRAWINGS FOR EMBEDDED ITEMS AND RECESSES NOT SHOWN ON STRUCTURAL DRAWINGS.
PRIOR TO POURING CONCRETE THE INDEPENDENT TESTING AGENCY SHALL INSPECT ALL FOUNDATION STEEL AND FOUNDATION SUBGRADE

PREPARED FOR:



1 INTERNATIONAL BOULEVARD
SUITE #800
MAHWAH, N.J. 07495

CONSULTANT:



POWDER RIVER

Development Services, LLC

100 E. SHENANGO STREET
SHARPSVILLE, PA 16150

724.962.5999

www.powderriverdev.com

PRDS PROJ.NO. 1181-081911

SITE NAME:

SPRING LAKE
FIRE STATION #43

SITE NUMBER:

SA13XC135

SITE ADDRESS:

2059 W. BITTERS ROAD
SAN ANTONIO, TX 78248

STAMP:



Table with columns: DRAWN BY, APPROVED BY, DATE DRAWN, REVISION, NO, DESCRIPTION, BY, DATE. Includes entries for SUBMISSION: 90% CD, FINALS, and FINALS-REV1.

SHEET TITLE:
GENERAL NOTES

SHEET NUMBER:
T-3

10.0 STRUCTURAL STEEL

MEET OR EXCEED MANUFACTURER'S RECOMMENDATIONS.

- A. UNLESS OTHERWISE NOTED, ALL DETAILING, FABRICATION AND PLACING OF REINFORCING STEEL SHALL CONFORM TO THE MANUAL OF STANDARD PRACTICE FOR DETAILING REINFORCED CONCRETE STRUCTURES (ACI 315).
- B. ALL REINFORCING STEEL SHALL BE NEW BILLET STEEL, CONFORMING TO ASTM A-615, GRADE 60, DEFORMED.
- C. HEATING AND WELDING OF BARS IS PROHIBITED WITH THE EXCEPTION OF WRITTEN APPROVAL BY THE STRUCTURAL ENGINEER.
- D. ALL REINFORCEMENT BARS TO BE FREE FROM LOOSE RUST AND SCALE.
- E. UNLESS OTHERWISE NOTED, ALL REINFORCEMENT SHALL HAVE A MINIMUM CONCRETE COVERAGE OF 3 INCHES. THIS MAY REQUIRE SPACERS AND CHAIRS AS REQUIRED BY TESTING AGENCY OR CONSTRUCTION MANAGER.
- F. SPLICES IN REINFORCEMENT STEEL ARE PROHIBITED, UNLESS APPROVED BY CONSTRUCTION MANAGER. ALL SPLICES MUST THEN MEET ALL APPLICABLE ASTM STANDARDS FOR SPLICING.

11.0 GROUNDING

MEET ALL APPLICABLE CODES, REQUIREMENTS OF THE CONSTRUCTION DOCUMENTS AND SPRINT WIRELESS CONSTRUCTION SPECIFICATIONS.

GENERATOR SPECIFICATIONS

- 1. SWITCHES AND STANDARD FEATURES
 - A. CYCLIC CRANKING
 - B. ALARM HORN WITH SILENCING SWITCH
 - C. VOLTAGE ADJUSTING RHEOSTAT
 - D. OVERVOLTAGE PROTECTION
 - E. REMOTE TWO-WIRE AUTO START SYSTEM
 - F. LAMP TEST SWITCH
 - G. RUN-OFF-RESET/AUTO SWITCH (ENGINE START)
 - H. ENGINE COOL DOWN TIMER (5 MINUTES)
- 2. ERROR-PROOF WIRING HARNESS FOR ELECTRICAL CONNECTIONS
- 3. PANEL LAMPS
- 4. DC CIRCUIT PROTECTION

UNIT ACCESSORIES

- 1. WEATHER HOUSING-STANDARD WITH ROOF MOUNTED SILENCER
- 2. MOUNTED CRITICAL GRADE EXHAUST SILENCER
- 3. TAIL PIPE AND RAIN CAP

COOLING SYSTEM ACCESSORIES

- 1. UNIT MOUNTED RADIATOR
- 2. ENGINE BLOCK HEATER

FUEL SYSTEM ACCESSORIES

- 1. FLEXIBLE FUEL LINES
- 2. ENGINE BLOCK HEATER
- 3. SUBBASE FUEL TANK-172 GALLONS
- 4. DOUBLE WALL CONSTRUCTION WITH LEAK DETECTION MONITOR
- 5. U.L. 142 LISTED
- 6. FUEL LEVEL GAUGE
- 7. LOW FUEL LEVEL ALARM
- 8. FILL PIPE EXTENDED 10% INTO TANK
- 9. HIGH-FUEL LEVEL ALARM-SET AT 95%
- 10. 7.5 GALLON LOCKABLE FILL WITH SPILL CONTAINMENT

GENERATOR ACCESSORIES

- 1. MAIN LINE CIRCUIT BREAKER-100 AMPS, INSTALLED ON GENERATOR
- 2. VOLTAGE REGULATOR ±2%
- 3. SAFEGUARD BREAKER

ENGINE ELECTRICAL ACCESSORIES

- 1. ELECTRONIC/ISOCRONOUS GOVERNOR
- 2. BATTERY RACK, CABLES AND STARTING BATTERY SYSTEM-LEAD ACID TYPE
- 3. BATTERY CHARGER-AUTOMATIC 6 AMP OUTPUT

UTILITY POLES

1. ALL UTILITY POLES SHALL BE 35 FT., CLASS 4 OR AS DIRECTED BY THE UTILITY PROVIDER. THE CONTRACTOR SHALL COORDINATE WITH THE UTILITY COMPANY PRIOR TO EXCAVATING OR INSTALLING ANY UTILITY POLES.

GENERAL NOTES:

1. THE GENERAL CONTRACTOR MUST VERIFY ALL DIMENSIONS, CONDITIONS AND ELEVATIONS BEFORE STARTING WORK. ALL DISCREPANCIES SHALL BE CALLED TO THE ATTENTION OF THE ENGINEER AND SHALL BE RESOLVED BEFORE PROCEEDING WITH THE WORK. ALL WORK SHALL BE PERFORMED IN A WORKMANLIKE MANNER IN ACCORDANCE WITH ACCEPTED CONSTRUCTION PRACTICES.

2. IT IS THE INTENTION OF THESE DRAWINGS TO SHOW THE COMPLETED INSTALLATION. THE CONTRACTOR SHALL BE RESPONSIBLE FOR ALL TEMPORARY BRACING, SHORING, 115, FORM WORK, ETC. IN ACCORDANCE WITH ALL NATIONAL, STATE AND LOCAL ORDINANCES TO SAFELY EXECUTE ALL WORK AND SHALL BE RESPONSIBLE FOR SAME. ALL WORK SHALL BE IN ACCORDANCE WITH LOCAL CODES.

3. THE CONTRACTOR SHALL USE ADEQUATE NUMBER OF SKILLED WORKMEN WHO ARE THOROUGHLY TRAINED AND EXPERIENCED IN THE NECESSARY CRAFTS AND WHO ARE COMPLETELY FAMILIAR WITH THE SPECIFIED REQUIREMENTS AND METHODS NEEDED FOR PROPER PERFORMANCE OF THE WORK.

4. CONSTRUCTION CONTRACTOR AGREES THAT IN ACCORDANCE WITH GENERALLY ACCEPTED CONSTRUCTION PRACTICES CONSTRUCTION CONTRACTOR WILL BE REQUIRED TO ASSUME SOLE AND COMPLETE RESPONSIBILITY FOR JOB SITE CONDITIONS DURING THE COURSE OF CONSTRUCTION OF THE PROJECT. INCLUDING THE SAFETY OF ALL PERSONS AND PROPERTY. THAT REQUIREMENT SHALL BE MADE TO APPLY CONTINUOUSLY AND NOT BE LIMITED TO NORMAL WORKING HOURS AND CONSTRUCTION CONTRACTOR FURTHER AGREES TO INDEMNIFY AND HOLD DESIGN ENGINEER HARMLESS FROM ANY AND ALL LIABILITY, REAL OR ALLEGED, IN CONNECTION WITH PERFORMANCE OF WORK ON THIS PROJECT.

5. SITE GROUNDING SHALL COMPLY WITH SPRINT/NEXTEL GROUNDING STANDARDS, LATEST EDITION AND COMPLY WITH SPRINT/NEXTEL GROUNDING CHECKLIST, LATEST VERSION. WHEN NATIONAL AND LOCAL GROUNDING CODES ARE MORE STRINGENT, THEY SHALL GOVERN. GROUNDING SHALL BE COMPLETED BEFORE ERECTION OF A NEW TOWER.

6. ALL WORK SHALL COMPLY WITH OSHA AND STATE SAFETY REQUIREMENTS. PROCEDURES FOR THE PROTECTION OF EXCAVATIONS, EXISTING CONSTRUCTION AND UTILITIES SHALL BE ESTABLISHED PRIOR TO FOUNDATION INSTALLATION. IF TEMPORARY LIGHTING AND MARKING ARE REQUIRED BY THE FEDERAL AVIATION ADMINISTRATION (FAA), IT IS THE CONTRACTOR'S RESPONSIBILITY TO MAINTAIN THE NECESSARY LIGHTS AND NOTIFY THE PROPER AUTHORITIES IN THE EVENT OF A PROBLEM.

7. ALL WORK SHALL BE ACCOMPLISHED IN ACCORDANCE WITH ALL LOCAL, STATE AND FEDERAL CODES OR ORDINANCES. THE MOST STRINGENT CODE WILL APPLY IN THE CASE OF DISCREPANCIES OR DIFFERENCES IN THE CODE REQUIREMENTS.

8. ANY DAMAGE TO ADJACENT PROPERTIES WILL BE CORRECTED AT THE CONTRACTOR'S EXPENSE

9. THE CONTRACTOR IS RESPONSIBLE FOR PROVIDING AMPLE NOTICE TO THE BUILDING INSPECTION DEPARTMENT TO SCHEDULE THE REQUIRED INSPECTIONS. A MINIMUM OF 24 HOURS OF NOTICE SHOULD BE GIVEN AND THE BUILDING INSPECTION DEPARTMENTS HAVE REQUESTED THAT GROUPS OF TWO OR THREE SITES BE SCHEDULED AT ONE TIME IF POSSIBLE.

10. FOR NEW TOWERS, SPRINT WILL CONFIRM FAA APPROVAL OF TOWER LOCATION BY ISSUING TOWER RELEASE FORM. NO TOWER SHALL BE CONSTRUCTED UNTIL TOWER RELEASE FORM IS ISSUED TO THE CONTRACTOR.

11. THE COMPLETE BID PACKAGE INCLUDES THESE CONSTRUCTION DRAWINGS ALONG WITH THE SPECIFICATIONS AND TOWER DRAWINGS/ANALYSIS. CONTRACTOR IS RESPONSIBLE FOR REVIEW OF THE TOTAL BID PACKAGE PRIOR TO BID SUBMITTAL.

12. THE CONTRACTOR SHALL VERIFY LOCATIONS OF ALL EXISTING UTILITIES WITHIN THE CONSTRUCTION LIMITS PRIOR TO CONSTRUCTION.

13. THE CONTRACTOR IS RESPONSIBLE FOR MAINTAINING POSITIVE DRAINAGE ON THE SITE AT ALL TIMES. SILT AND EROSION CONTROL SHALL BE MAINTAINED ON THE DOWNSTREAM SIDE OF THE SITE AT ALL TIMES. ANY DAMAGE TO ADJACENT PROPERTIES WILL BE CORRECTED AT THE CONTRACTORS EXPENSE.

14. CLEARING OF TREES AND VEGETATION ON THE SITE SHOULD BE KEPT TO A MINIMUM. ONLY THE TREES NECESSARY FOR CONSTRUCTION OF THE FACILITIES SHALL BE REMOVED. ANY DAMAGE TO PROPERTY OUTSIDE THE LEASED PROPERTY SHALL BE REPAIRED BY THE CONTRACTOR.

15. ALL SUITABLE BORROW MATERIAL FOR BACKFILL OF THE SITE SHALL BE INCLUDED IN THE BID. EXCESS TOPSOIL AND UNSUITABLE MATERIAL SHALL BE DISPOSED OF OFF SITE AT LOCATIONS APPROVED BY GOVERNING AGENCIES PRIOR TO DISPOSAL.

16. SEEDING AND MULCHING OF THE SITE WILL BE ACCOMPLISHED AS SOON AS POSSIBLE AFTER COMPLETION OF THE SITE DEVELOPMENT. THE CONTRACTOR IS RESPONSIBLE FOR PROVIDING AND MAINTAINING AN ADEQUATE COVER OF VEGETATION OVER THE SITE FOR A ONE YEAR PERIOD.

17. PERMITS: THE CONTRACTOR SHALL OBTAIN AND PAY FOR ALL REQUIRED PERMITS, LICENSES, FEES, INSPECTIONS, ETC. AND PROVIDE E911 ADDRESS TO SPRINT WIRELESS.

18. RECORD DRAWINGS: MAINTAIN A RECORD OF ALL CHANGES, SUBSTITUTIONS, ETC., BETWEEN THE WORK AS SPECIFIED AND INSTALLED. RECORD CHANGES ON A CLEAN SET OF CONTRACT DRAWINGS WHICH SHALL BE TURNED OVER TO THE CONSTRUCTION MANAGER UPON COMPLETION OF THE PROJECT.

EXCAVATION AND GRADING NOTES:

1. ALL CUT AND FILL SLOPES SHALL BE 3:1 MAXIMUM.

2. ALL EXCAVATIONS ON WHICH CONCRETE IS TO BE PLACED SHALL BE SUBSTANTIALLY HORIZONTAL ON UNDISTURBED AND UNFROZEN SOIL AND BE FREE FROM LOOSE MATERIAL AND EXCESS GROUND WATER. DEWATERING FOR EXCESS GROUND WATER SHALL BE PROVIDED IF REQUIRED.

3. CONCRETE FOUNDATIONS SHALL NOT BE PLACED ON ORGANIC MATERIAL IF SOUND SOIL IS NOT REACHED AT THE DESIGNATED EXCAVATION DEPTH. THE UNSATISFACTORY SOIL SHALL BE EXCAVATED TO ITS FULL DEPTH AND EITHER BE REPLACED WITH MECHANICALLY COMPACTED GRANULAR MATERIAL OR THE EXCAVATION SHALL BE FILLED WITH CONCRETE OF THE SAME QUALITY SPECIFIED FOR THE FOUNDATION.

4. ANY EXCAVATION OVER THE REQUIRED DEPTH SHALL BE FILLED WITH EITHER MECHANICALLY COMPACTED GRANULAR MATERIAL OR CONCRETE OF THE SAME QUALITY SPECIFIED FOR THE FOUNDATION. CRUSHED STONE MAY BE USED TO STABILIZE THE BOTTOM OF THE EXCAVATION. STONE, IF USED, SHALL NOT BE USED AS COMPILING CONCRETE THICKNESS.

5. AFTER COMPLETION OF THE FOUNDATION AND OTHER CONSTRUCTION BELOW GRADE AND BEFORE BACKFILLING, ALL EXCAVATIONS SHALL BE CLEAN OF UNSUITABLE MATERIAL SUCH AS VEGETATION, TRASH, DEBRIS AND SO FORTH.

6. ALL BACKFILLING SHALL (1) USE APPROVED MATERIALS CONSISTING OF EARTH, LOAM, SANDY CLAYS, SAND AND GRAVEL OR SOFT SHALE, (2) BE FREE FROM CLODS OR STONES OVER 2 1/2" MAXIMUM DIMENSIONS. MD (3) BE PLACED IN LAYERS AND COMPACTED.

7. SITE FILL MATERIAL AND FOUNDATION BACKFILL SHALL BE PLACED IN LAYERS MAXIMUM 6' DEEP BEFORE COMPACTION. EACH LAYER SHALL BE SPRINKLED IF REQUIRED AND COMPACTED BY HAND OR MACHINE TAMPERS TO 95% OF MAXIMUM DENSITY. AT THE OPTIMUM MOISTURE CONTENT OF ±2% AS DETERMINED BY ASTM DESIGNATION D-69B, UNLESS OTHERWISE APPROVED. SUCH BACKFILL SHALL NOT BE PLACED BEFORE 3 DAYS AFTER PLACEMENT OF CONCRETE.

8. THE FOUNDATION AREA SHALL BE GRADED TO PROVIDE WATER RUNOFF AND PREVENT WATER FROM STANDING. THE FINAL GRADE SHALL SLOPE AWAY IN ALL DIRECTIONS FROM THE FOUNDATION AREA (UP TO ONE FOOT OUTSIDE THE FENCE OR GROUND SYSTEM PERIMETER) AND SHALL BE COVERED WITH A GEOTEXTILE FABRIC MIRAFI 500X OR APPROVED EQUAL TO PREVENT REOCCURRENCE OF VEGETATIVE GROWTH, AN THEN SHALL BE COVERED WITH 4" DEEP COMPACTED STONE OR GRAVEL.

9. THE CONTRACTOR SHALL PROVIDE ALL EROSION AND SEDIMENTATION CONTROL MEASURES AS REQUIRED BY LOCAL, CITY, COUNTY AND STATE CODES AND ORDINANCES TO PROTECT EMBANKMENT FROM SOIL LOSS AND TO PREVENT ACCUMULATION OF SOIL AND SILT IN STREAMS AND DRAINAGE PATHS FROM LEAVING THE CONSTRUCTION AREA. THIS MAY INCLUDE SUCH MEASURES AS SILT FENCES, STRAW BALE SEDIMENT BARRIERS AND CHECK DAMS.

10. FILL PREPARATION: REMOVE ALL VEGETATION, TOPSOIL DEBRIS, WET AND UNSATISFACTORY SOIL MATERIALS, OBSTRUCTIONS AND DELETERIOUS MATERIAL FROM GROUND SURFACE PRIOR TO PLACING FILLS, PLOW STRIP OR BREAK UP SLOPED SURFACES STEEPER THAN 1 VERTICAL TO 4 HORIZONTAL SO FILL MATERIAL WILL BOND WITH EXISTING SURFACE WHEN SUBGRADE OR EXISTING GROUND SURFACE TO RECEIVE FILL HAS A DENSITY LESS THAN THAT REQUIRED FOR FILL, BREAK UP GROUND SURFACE TO REQUIRED DEPTH, PULVERIZE, MOISTURE CONDITION OR AERATE SOIL AND RECOMPACT TO REQUIRED DENSITY.

11. REPLACE EXISTING GRAVEL SURFACING ON AREAS FROM WHICH GRAVEL SURFACING IS REMOVED DURING CONSTRUCTION OPERATIONS. GRAVEL SURFACING SHALL BE REPLACED TO MATCH EXISTING ADJACENT GRAVEL SURFACING AND SHALL BE OF THE SAME THICKNESS. SURFACES AND GRAVEL SURFACING SHALL BE FREE FROM CORRUGATIONS AND WAVES. EXISTING GRAVEL SURFACING MAY BE EXCAVATED SEPARATELY AND REUSED IF INJURIOUS AMOUNTS OF EARTH, ORGANIC MATTER, OR OTHER DELETERIOUS MATERIALS ARE REMOVED PRIOR TO REUSE. FURNISH ALL ADDITIONAL GRAVEL RESURFACING MATERIAL AS REQUIRED. BEFORE GRAVEL SURFACING IS REPLACED, SUBGRADE SHALL BE GRADE TO CONFORM TO REQUIRED SUBGRADE ELEVATIONS, AND LOOSE OR DISTURBED MATERIALS SHALL BE THOROUGHLY COMPACTED. DEPRESSIONS IN THE SUBGRADE SHALL BE FILLED AND COMPACTED WITH APPROVED SELECTED MATERIAL. GRAVEL SURFACING MATERIAL SHALL NOT BE USED FOR FILLING DEPRESSIONS IN THE SUBGRADE.

12. PROTECT EXISTING GRAVEL SURFACING AND SUBGRADE IN AREAS WHERE EQUIPMENT LOADS WILL OPERATE, USE PLANKING OR OTHER SUITABLE MATERIALS DESIGNED TO SPREAD EQUIPMENT LOADS. REPAIR ANY DAMAGE TO EXISTING GRAVEL SURFACING OR SUBGRADE WHERE SUCH DAMAGE IS DUE TO THE CONTRACTOR'S OPERATIONS.

13. DAMAGE TO EXISTING STRUCTURES AND UTILITIES RESULTING FROM CONTRACTORS NEGLIGENCE SHALL BE REPAIRED/REPLACED TO OWNER'S SATISFACTION AT CONTRACTOR'S EXPENSE.

14. CONTRACTOR SHALL COORDINATE THE CONSTRUCTION SCHEDULE WITH THE PROPERTY OWNER SO AS TO AVOID INTERRUPTIONS TO PROPERTY OWNER'S OPERATIONS.

15. ENSURE POSITIVE DRAINAGE DURING AND AFTER COMPLETION OF CONSTRUCTION.

16. RIPRAP SHALL BE CLEAN, HARD, SOUND, DURABLE AND UNIFORM IN QUALITY AND FREE OF ANY DETRIMENTAL QUANTITY OF SOFT, FRIABLE, THIN, ELONGATED OR LAMINATED PIECES, DISINTEGRATED MATERIAL, ORGANIC MATTER, OIL, ALKALI OR OTHER DELETERIOUS SUBSTANCE.

PREPARED FOR:



1 INTERNATIONAL BOULEVARD
SUITE #800
MAHWAH, N.J. 07495

CONSULTANT:



POWDER RIVER

Development Services, LLC

100 E. SHENANGO STREET
SHARPSVILLE, PA 16150

724.962.5999

www.powderriverdev.com

PRDS PROJ.NO. 1181-081911

SITE NAME:

**SPRING LAKE
FIRE STATION #43**

SITE NUMBER:

SA13XC135

SITE ADDRESS:

2059 W. BITTERS ROAD
SAN ANTONIO, TX 78248

STAMP:



DRAWN BY: KE

APPROVED BY: G.W.C.

DATE DRAWN: 09/07/11

REVISION

NO	DESCRIPTION	BY	DATE
△	SUBMISSION: 90% CD	KE	09/07/11
△	FINALS	TM	11/07/11
△	FINALS-REV1	TM	08/17/12

SHEET TITLE:

GENERAL NOTES

SHEET NUMBER:

T-4

ABBREVIATIONS

AFF	ABOVE FINISHED FLOOR
AGL	ABOVE GRADE LEVEL
AMSL	ABOVE MEAN SEA LEVEL
APPROX	APPROXIMATE
AWG	AMERICAN WIRE GAUGE
BLDG	BUILDING
BTS	BASE TRANSMISSION STATION
CLR	CLEAR
COL	COLUMN
CONC	CONCRETE
CND	CONDUIT
DWG	DRAWING
FT	FOOT (FEET)
EGB	EQUIPMENT GROUND BAR
ELEC	ELECTRICAL
EMT	ELECTRICAL METALLIC TUBING
ELEV	ELEVATION
EQUIP	EQUIPMENT
(E)	EXISTING
EXT	EXTERIOR
FND	FOUNDATION
F	FIBER
GA	GAUGE
GALV	GALVANIZED
GPS	GLOBAL POSITIONING SYSTEM
GND	GROUND
LTE	LONG TERM EVOLUTION
MAX	MAXIMUM
MFR	MANUFACTURER
MGB	MASTER GROUND BAR
MIN	MINIMUM
N.T.S.	NOT TO SCALE
O.C.	ON CENTER
OE/OT	OVERHEAD ELECTRIC/TELCO
PPC	POWER PROTECTION CABINET
RBS	RADIO BASED STATION
RRU	REMOTE RADIO UNIT
RGS	RIGID GALVANIZED STEEL
IN	INCH(ES)
INT	INTERIOR
LB(S) or #	POUND(S)
SF	SQUARE FOOT
STL	STEEL
TYP	TYPICAL
UE/UT	UNDERGROUND ELECTRIC/TELCO
UNO	UNLESS NOTED OTHERWISE
VIF	VERIFY IN FIELD
W/	WITH
XFMR	TRANSFORMER

SYMBOLS

	REVISION
	WORK POINT
	UTILITY POLE
	BRICK
	COMPRESSED STONE
	CONCRETE
	EARTH
	GRAVEL
	MASONRY
	STEEL
	CENTERLINE
	PROPERTY LINE
	LEASE LINE
	EASEMENT LINE
	CHAIN LINK FENCE
	WOOD FENCE
	UNDERGROUND ELECTRIC
	UNDERGROUND TELEPHONE
	OVERHEAD ELECTRIC/TELEPHONE

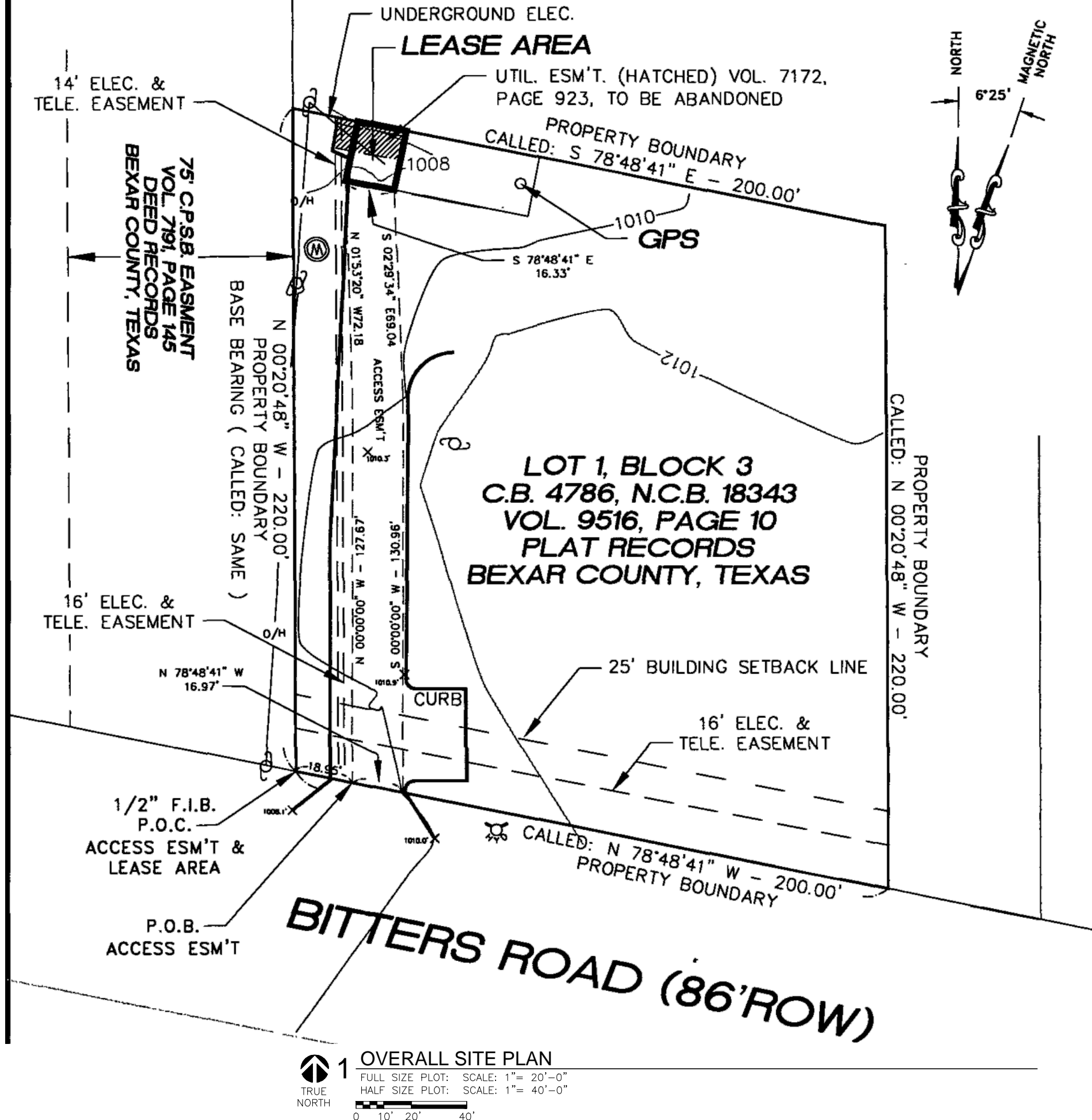

1 OVERALL SITE PLAN
 FULL SIZE PLOT: SCALE: 1" = 20'-0"
 HALF SIZE PLOT: SCALE: 1" = 40'-0"

PREPARED FOR:



1 INTERNATIONAL BOULEVARD
 SUITE #800
 MAHWAH, N.J. 07495

CONSULTANT:



POWDER RIVER
 Development Services, LLC
 100 E. SHENANGO STREET
 SHARPSVILLE, PA 16150
 724.962.5999
 www.powderriverdev.com
 PRDS PROJ.NO. 1181-081911

SITE NAME:
**SPRING LAKE
 FIRE STATION #43**

SITE NUMBER:
SA13XC135

SITE ADDRESS:
 2059 W. BITTERS ROAD
 SAN ANTONIO, TX 78248

STAMP:

**FOR
 REFERENCE
 ONLY**

DRAWN BY:	KE		
APPROVED BY:	G.W.C.		
DATE DRAWN:	09/07/11		
REVISION			
NO	DESCRIPTION	BY	DATE
1	SUBMISSION: 90% CD	KE	09/07/11
2	FINALS	TM	11/07/11
3	FINALS-REV1	TM	08/17/12

SHEET TITLE:
OVERALL SITE PLAN

SHEET NUMBER:
A-1

ABBREVIATIONS

AFF	ABOVE FINISHED FLOOR
AGL	ABOVE GRADE LEVEL
AMSL	ABOVE MEAN SEA LEVEL
APPROX	APPROXIMATE
AWG	AMERICAN WIRE GAUGE
BLDG	BUILDING
BTS	BASE TRANSMISSION STATION
CLR	CLEAR
COL	COLUMN
CONC	CONCRETE
CND	CONDUIT
DWG	DRAWING
FT	FOOT (FEET)
EGB	EQUIPMENT GROUND BAR
ELEC	ELECTRICAL
EMT	ELECTRICAL METALLIC TUBING
ELEV	ELEVATION
EQUIP	EQUIPMENT
(E)	EXISTING
EXT	EXTERIOR
FND	FOUNDATION
F	FIBER
GA	GAUGE
GALV	GALVANIZED
GPS	GLOBAL POSITIONING SYSTEM
GND	GROUND
LTE	LONG TERM EVOLUTION
MAX	MAXIMUM
MFR	MANUFACTURER
MGB	MASTER GROUND BAR
MIN	MINIMUM
N.T.S.	NOT TO SCALE
O.C.	ON CENTER
OE/OT	OVERHEAD ELECTRIC/TELCO
PPC	POWER PROTECTION CABINET
RBS	RADIO BASED STATION
RRU	REMOTE RADIO UNIT
RGS	RIGID GALVANIZED STEEL
IN	INCH(ES)
INT	INTERIOR
LB(S) or #	POUND(S)
SF	SQUARE FOOT
STL	STEEL
TYP	TYPICAL
UE/UT	UNDERGROUND ELECTRIC/TELCO
UNO	UNLESS NOTED OTHERWISE
VIF	VERIFY IN FIELD
W/	WITH
XFMR	TRANSFORMER

SYMBOLS

	REVISION
	WORK POINT
	UTILITY POLE
	BRICK
	COMPRESSED STONE
	CONCRETE
	EARTH
	GRAVEL
	MASONRY
	STEEL
	CENTERLINE
	PROPERTY LINE
	LEASE LINE
	EASEMENT LINE
	CHAIN LINK FENCE
	WOOD FENCE
	UNDERGROUND ELECTRIC
	UNDERGROUND TELEPHONE
	OVERHEAD ELECTRIC/TELEPHONE

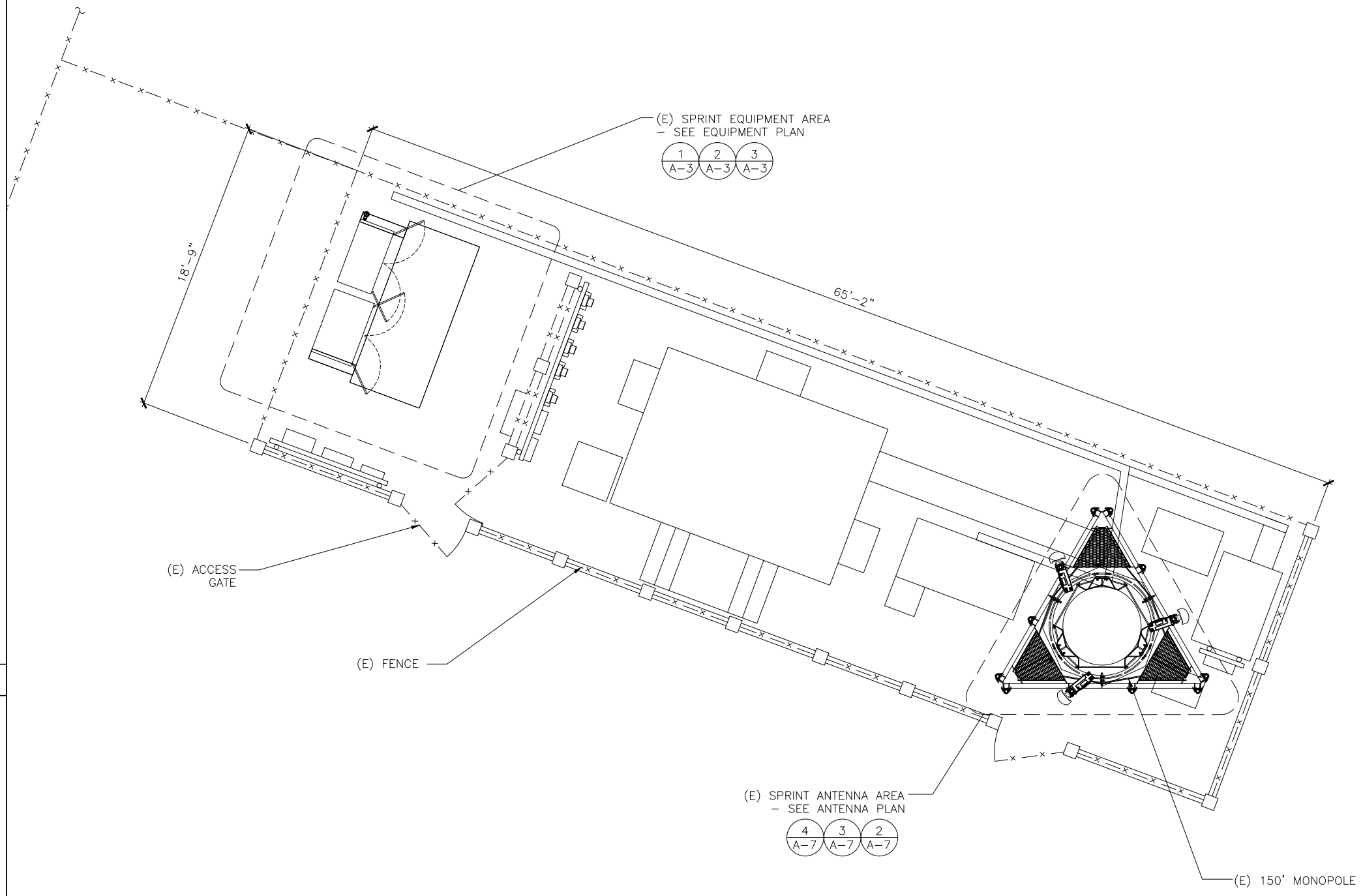

1 ENLARGED SITE PLAN
 FULL SIZE PLOT: SCALE: 1/4" = 1'-0"
 HALF SIZE PLOT: SCALE: 1/2" = 1'-0"
 0 1.5' 3' 5'

PREPARED FOR:



1 INTERNATIONAL BOULEVARD
 SUITE #800
 MAHWAH, N.J. 07495

CONSULTANT:



POWDER RIVER
 Development Services, LLC
 100 E. SHENANGO STREET
 SHARPSVILLE, PA 16150
 724.962.5999
 www.powderriverdev.com
 PRDS PROJ.NO. 1181-081911

SITE NAME:
**SPRING LAKE
 FIRE STATION #43**

SITE NUMBER:
SA13XC135

SITE ADDRESS:
 2059 W. BITTERS ROAD
 SAN ANTONIO, TX 78248

STAMP:

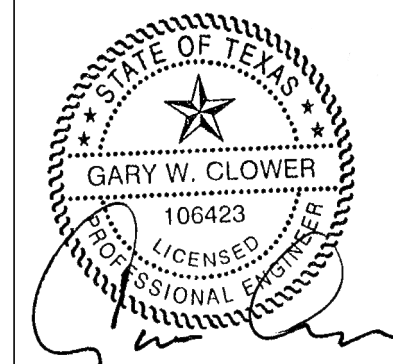

DRAWN BY:	KE		
APPROVED BY:	G.W.C.		
DATE DRAWN:	09/07/11		
REVISION			
NO	DESCRIPTION	BY	DATE
1	SUBMISSION: 90% CD	KE	09/07/11
2	FINALS	TM	11/07/11
3	FINALS-REV1	TM	08/17/12

SHEET TITLE:
ENLARGED SITE PLAN

SHEET NUMBER:

A-2

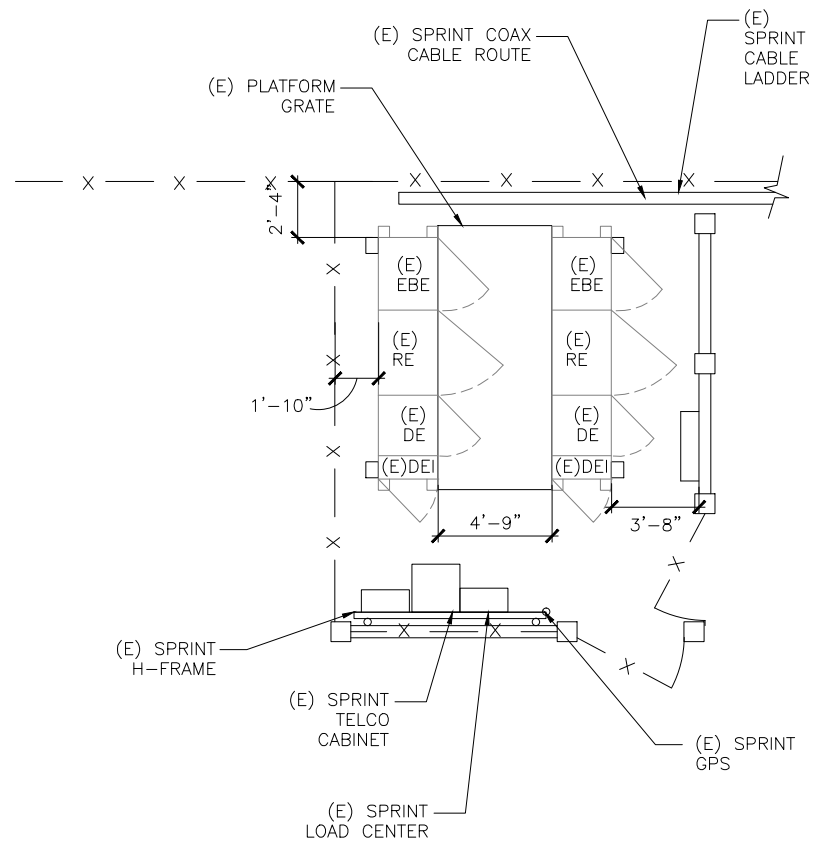

3 EQUIPMENT SITE PLAN (EXISTING)
 FULL SIZE PLOT: SCALE: 1/4" = 1'-0"
 HALF SIZE PLOT: SCALE: 1/8" = 1'-0"
 TRUE NORTH

COLD SLIDE

2 NOT USED
 FULL SIZE PLOT: SCALE: 1/4" = 1'-0"
 HALF SIZE PLOT: SCALE: 1/8" = 1'-0"
 TRUE NORTH

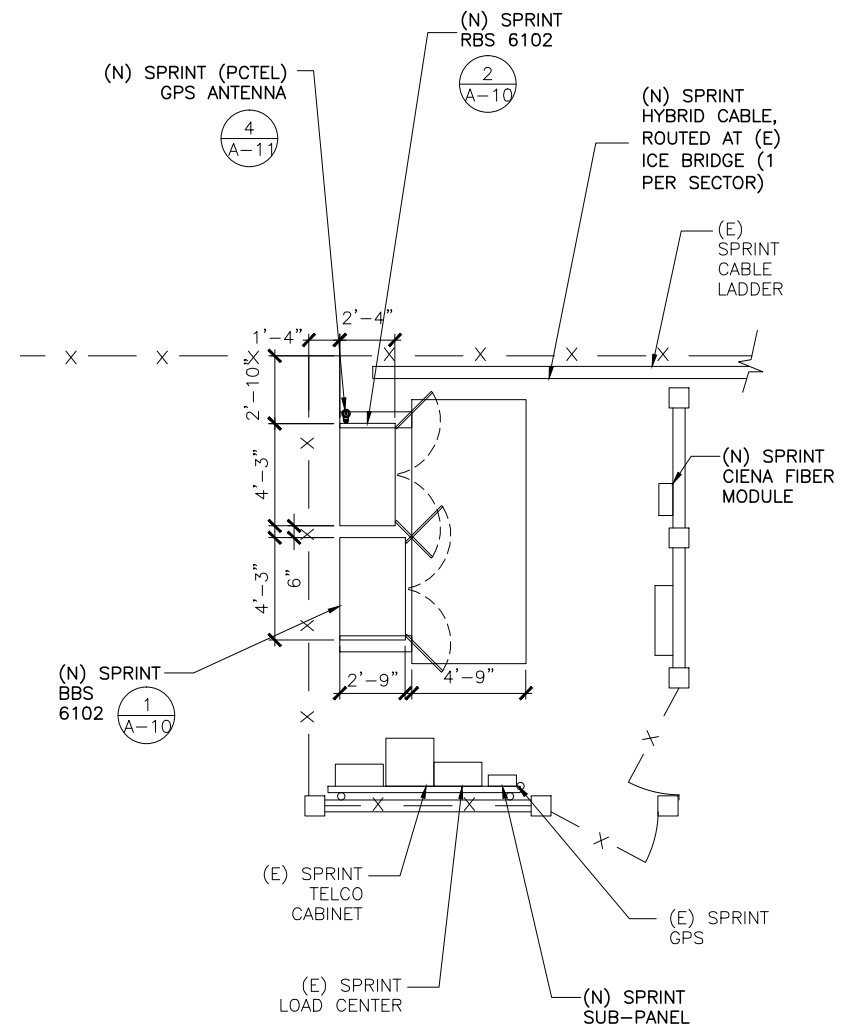

1 EQUIPMENT SITE PLAN (FINAL)
 FULL SIZE PLOT: SCALE: 1/4" = 1'-0"
 HALF SIZE PLOT: SCALE: 1/8" = 1'-0"
 TRUE NORTH

PREPARED FOR:



1 INTERNATIONAL BOULEVARD
 SUITE #800
 MAHWAH, N.J. 07495

CONSULTANT:



POWDER RIVER
 Development Services, LLC
 100 E. SHENANGO STREET
 SHARPSVILLE, PA 16150
 724.962.5999
 www.powderriverdev.com
 PRDS PROJ.NO. 1181-081911

SITE NAME:
**SPRING LAKE
 FIRE STATION #43**

SITE NUMBER:
SA13XC135

SITE ADDRESS:
 2059 W. BITTERS ROAD
 SAN ANTONIO, TX 78248

STAMP:

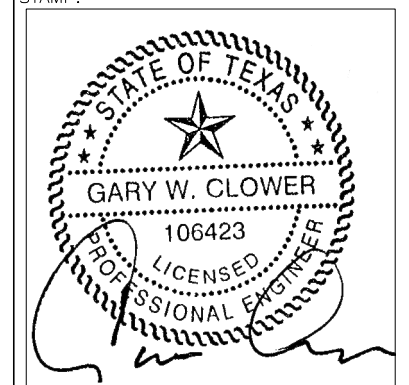

DRAWN BY:	KE		
APPROVED BY:	G.W.C.		
DATE DRAWN:	09/07/11		
REVISION			
NO	DESCRIPTION	BY	DATE
△	SUBMISSION: 90% CD	KE	09/07/11
△	FINALS	TM	11/07/11
△	FINALS-REV1	TM	08/17/12

SHEET TITLE:
EQUIPMENT PLANS

SHEET NUMBER:
A-3

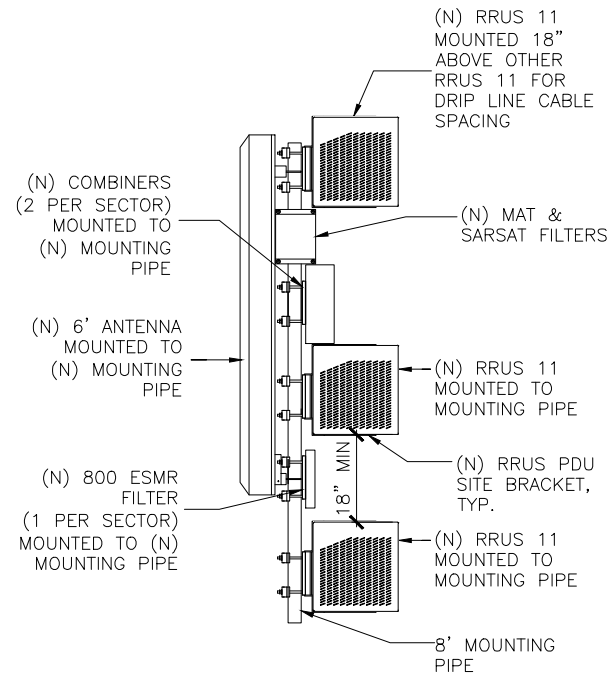

SIDE VIEW WITH 6' ANTENNA

3 ANTENNA DETAIL (FINAL CONFIGURATION)
SCALE: N.T.S.

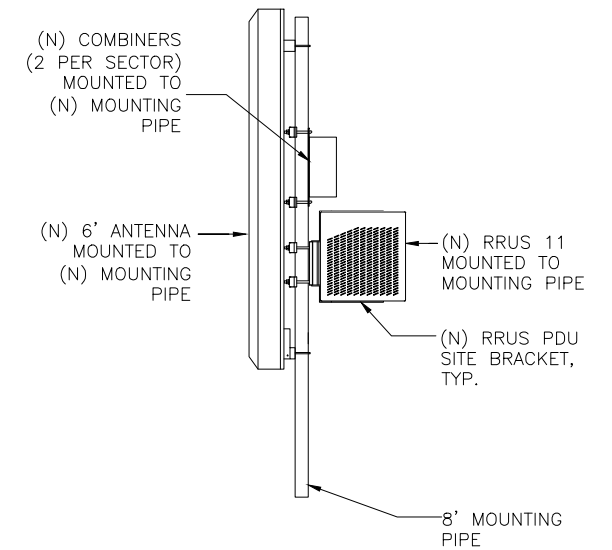

SIDE VIEW WITH 6' ANTENNA

2 ANTENNA DETAIL (FIRST TOUCH)
SCALE: N.T.S.

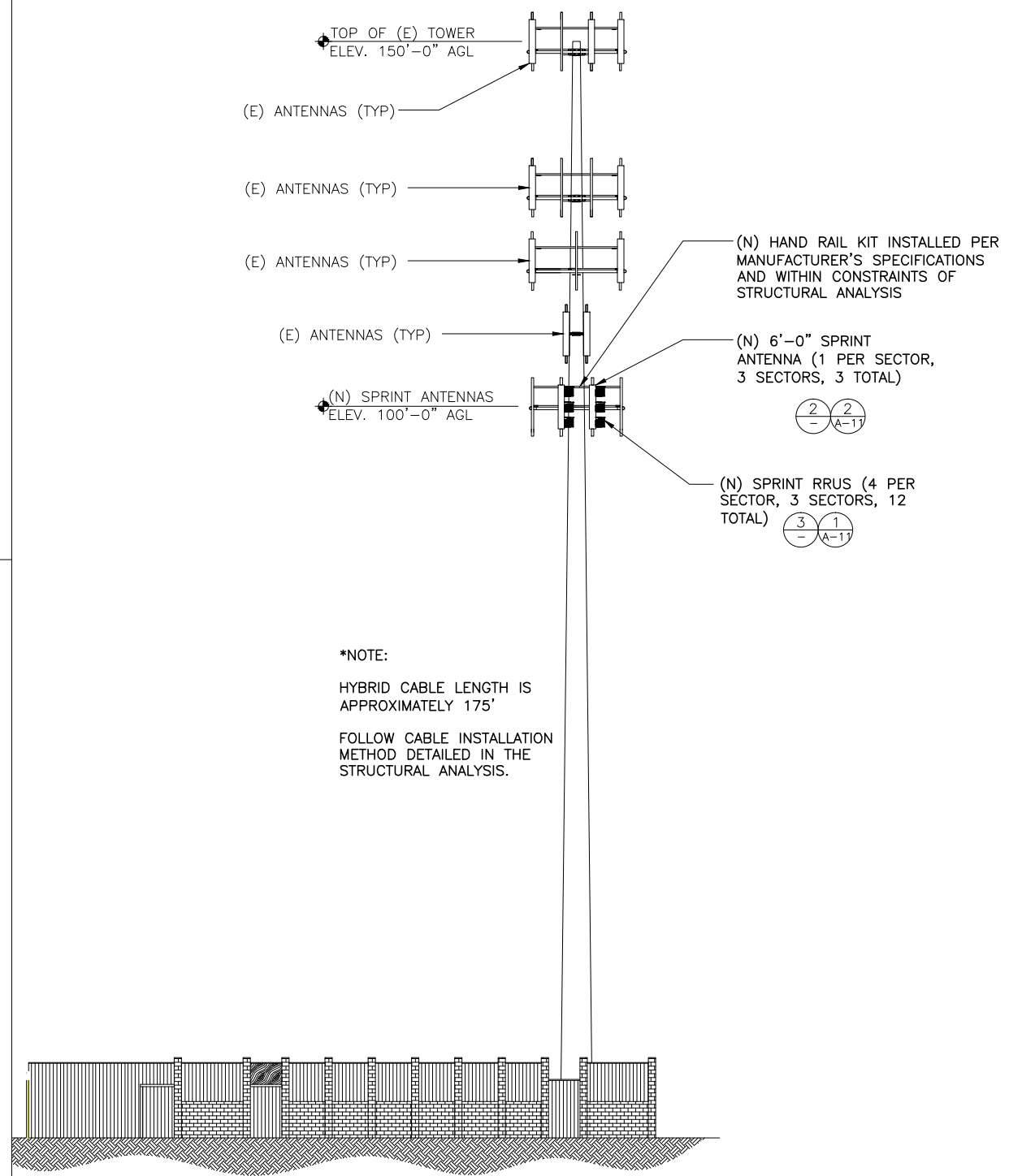

1 SITE ELEVATION
SCALE: 3/32" = 1'-0"

ERICSSON RRUS-11
-DIMENSIONS (H x W x D): 17.8" x 17.0" x 7.2" (INCLUDES SUNSHIELD)
-WEIGHT: 55 LBS
-CLIMATE: -40°C TO +55°C (SELF CONVECTION SILENT, NO FANS, IP55)
-POWER CONSUMPTION: 200 WATTS (TYP.)

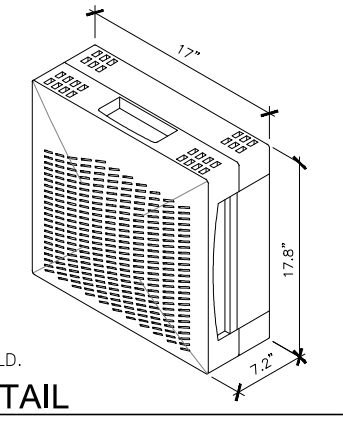

NOTE: RRUS CAN ONLY BE PAINTED ON SOLAR SHIELD.

4 RRUS DETAIL
SCALE: N.T.S.

- NOTES:**
- CONTRACTOR TO FIELD VERIFY ANTENNA CABLE LENGTHS.
 - ALL MAIN CABLES WILL BE COLOR CODED AT THREE (3) LOCATIONS.
 - COLOR CODE ALL ANTENNA AND COAX WITH 2" WIDE BANDS OF COLORED TAPE WITH 1" SEPARATION BETWEEN BANDS - SEE SHEET A-8 & A-9
 - COLOR CODE ALL TOP AND BOTTOM GROUND KITS WITH 1" WIDE BANDS OF COLORED TAPE WITH 1/2" SEPARATION BETWEEN BANDS.
 - START COLOR BANDS 2" BEYOND WEATHERPROOFING.
 - START SECTOR COLOR NEXT TO END CONNECTOR.
 - ALL MAIN CABLES WILL BE GROUNDED W/ COAXIAL CABLE GROUND KITS AT:
 - THE ANTENNA LEVEL
 - MID LEVEL IF TOWER IS OVER 200'
 - BASE OF TOWER PRIOR TO TURNING HORIZONTAL
 - TERMINATION OF COAX LINES TO JUMPERS
 - ALL NEW GROUND BAR DOWNLOADS ARE TO BE CADWELDED TO THE EXISTING ADJACENT GROUND BAR DOWNLOADS A MINIMUM DISTANCE OF 4FT BELOW GROUND BAR
 - PROVIDE BUSS BAR NEAR BTS FOR ATTACHMENT OF WIMAX COAX GROUND KITS

- COAXIAL ANTENNA CABLE NOTES:**
- THE ANTENNA COAXIAL CABLE INSTALLER SHALL BE RESPONSIBLE FOR PERFORMING AND SUPPLYING SPRINT WITH 3 TYPED SWEEP TESTS (ANTENNA RETURN LOSS TEST). THIS TEST SHALL BE PERFORMED TO THE SPECIFICATIONS AND PARAMETERS OUTLINED BY THE SPRINT RADIO FREQUENCY (RF) ENGINEER. THIS TEST SHALL BE PERFORMED PRIOR TO FINAL ACCEPTANCE OF THE SITE/
 - THE COAXIAL ANTENNA CABLE INSTALLER SHALL BE RESPONSIBLE FOR PERFORMING AND SUPPLYING SPRINT WITH 3 TYPED TIME DOMAIN REFLECTOMETER (TDR) TESTS TO VERIFY CABLE LENGTH AND TO CHECK FOR WATER DAMAGE.
 - VAPOR WRAP WILL BE USED TO SEAL ALL CONNECTIONS.
 - ALL JUMPERS TO THE ANTENNAS FROM THE MAIN TRANSMISSION LINE WILL BE 1/2" JUMPERS AND SHALL NOT EXCEED 6'-0". MAXIMUM LENGTH FOR THE JUMPERS AT WIMAX BTS UNITS WILL BE 6'-0".
 - IF COAX IS BEING RE-USED FOR THIS INSTALLATION, PRE AND POST ANTENNA LINE SWEEPS ARE REQUIRED.
 - UPON COMPLETION, PROVIDE A HEIGHT VERIFICATION DEPICTING RAD CENTER AND TOP OF ANTENNA.

- NOTES:**
- ALL AZIMUTHS ARE TO BE ESTABLISHED CLOCKWISE FROM THE TRUE NORTH HEADING.
 - CONTRACTOR SHALL VERIFY PROPOSED ANTENNA RAD CENTER AND ORIENTATIONS WITH SPRINT PCS PRIOR TO INSTALLATION OF ANTENNAS.
 - PRIOR TO ATTACHING ANTENNAS AND MOUNTING SECTIONS, EXISTING TOWER AND TOWER FOUNDATION MUST BE ANALYZED BY A LICENSED STRUCTURAL ENGINEER TO VERIFY TOWER IS CAPABLE OF SUPPORTING THE PROPSD LOADS. REFER TO STRUCTURAL ANALYSIS BY OTHERS.
 - CONTRACTOR SHALL REFER TO TOWER STRUCTURAL CALCULATIONS FOR ADDITIONAL LOADS. NO ERECTION OR MODIFICATION OF TOWER SHALL BE MADE WITHOUT APPROVAL OF STRUCTURAL ENGINEER.

PREPARED FOR:

1 INTERNATIONAL BOULEVARD
SUITE #800
MAHWAH, N.J. 07495

CONSULTANT:

POWDER RIVER
Development Services, LLC
100 E. SHENANGO STREET
SHARPSVILLE, PA 16150
724.962.5999
www.powderriverdev.com
PRDS PROJ.NO. 1181-081911

SITE NAME:
SPRING LAKE FIRE STATION #43

SITE NUMBER:
SA13XC135

SITE ADDRESS:
2059 W. BITTERS ROAD
SAN ANTONIO, TX 78248

STAMP:

DRAWN BY:	KE		
APPROVED BY:	G.W.C.		
DATE DRAWN:	09/07/11		
REVISION			
NO	DESCRIPTION	BY	DATE
△	SUBMISSION: 90% CD	KE	09/07/11
△	FINALS	TM	11/07/11
△	FINALS-REV1	TM	08/17/12

SHEET TITLE:
SITE ELEVATION & ANTENNA DETAILS

SHEET NUMBER:
A-4

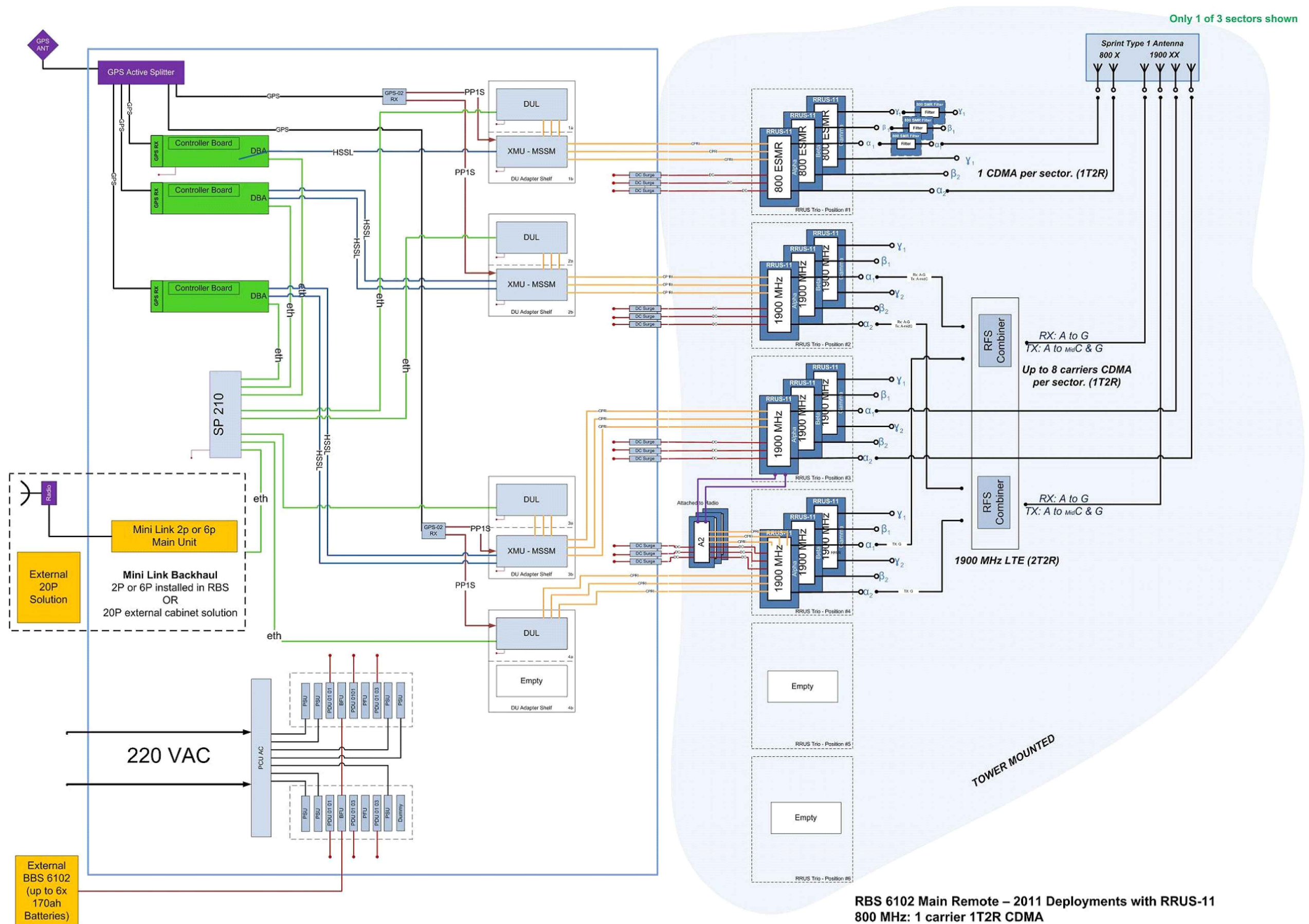

RBS 6102 Main Remote – 2011 Deployments with RRUS-11
 800 MHz: 1 carrier 1T2R CDMA
 1900 MHz: up to 8 carriers 1T2R CDMA
 1900 MHz: 5 MHz 2T2R LTE

PREPARED FOR:
Sprint
 1 INTERNATIONAL BOULEVARD
 SUITE #800
 MAHWAH, N.J. 07495

CONSULTANT:

POWDER RIVER
 Development Services, LLC
 100 E. SHENANGO STREET
 SHARPSVILLE, PA 16150
 724.962.5999
 www.powderriverdev.com
 PRDS PROJ.NO. 1181-081911

SITE NAME:
**SPRING LAKE
 FIRE STATION #43**
 SITE NUMBER:
SA13XC135
 SITE ADDRESS:
 2059 W. BITTERS ROAD
 SAN ANTONIO, TX 78248

STAMP:

 STATE OF TEXAS
 GARY W. CLOWER
 106423
 LICENSED PROFESSIONAL ENGINEER

DRAWN BY:	KE		
APPROVED BY:	G.W.C.		
DATE DRAWN:	09/07/11		
REVISION			
NO	DESCRIPTION	BY	DATE
1	SUBMISSION: 90% CD	KE	09/07/11
2	FINALS	TM	11/07/11
3	FINALS-REV1	TM	08/17/12

SHEET TITLE:
**ANTENNA PLUMBING
 DIAGRAMS**
 SHEET NUMBER:
A-6

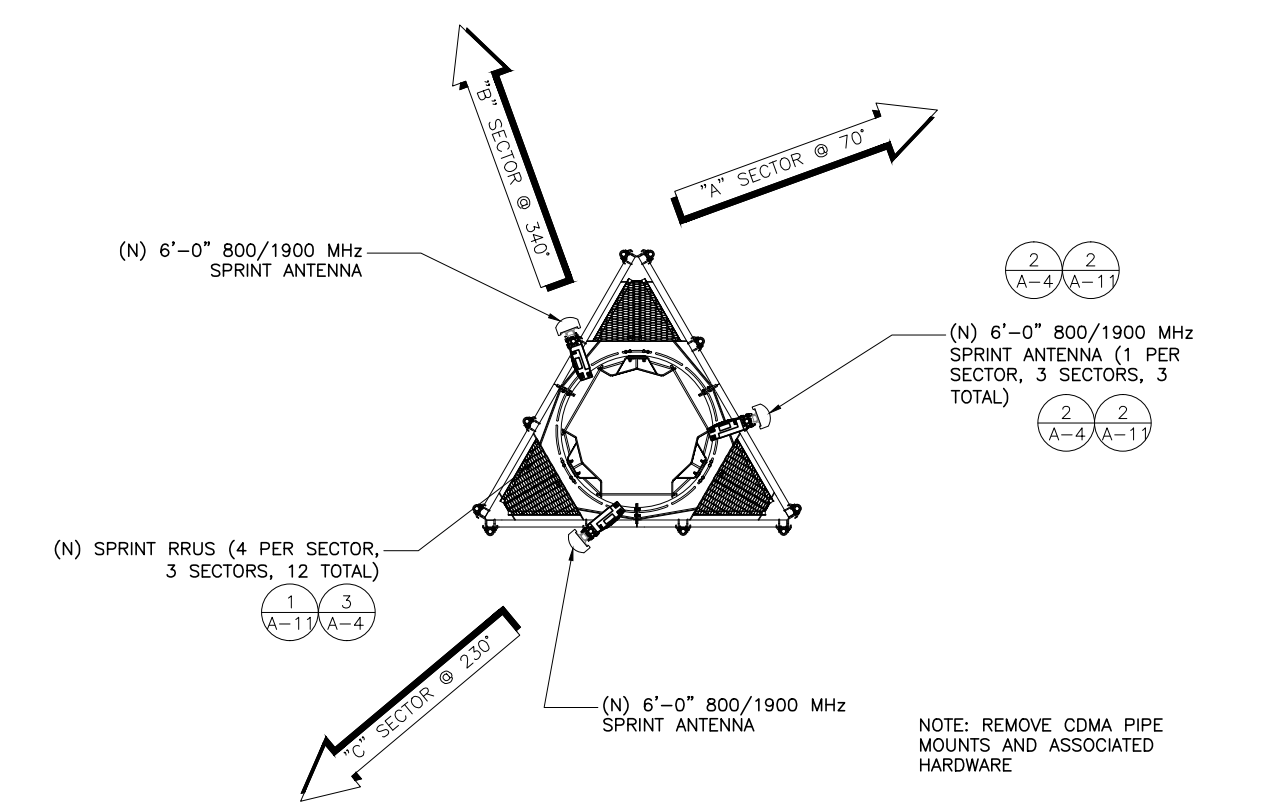

4 PROPOSED ANTENNA PLAN - FINAL
 SCALE: 1/4" = 1'-0"
 TRUE NORTH

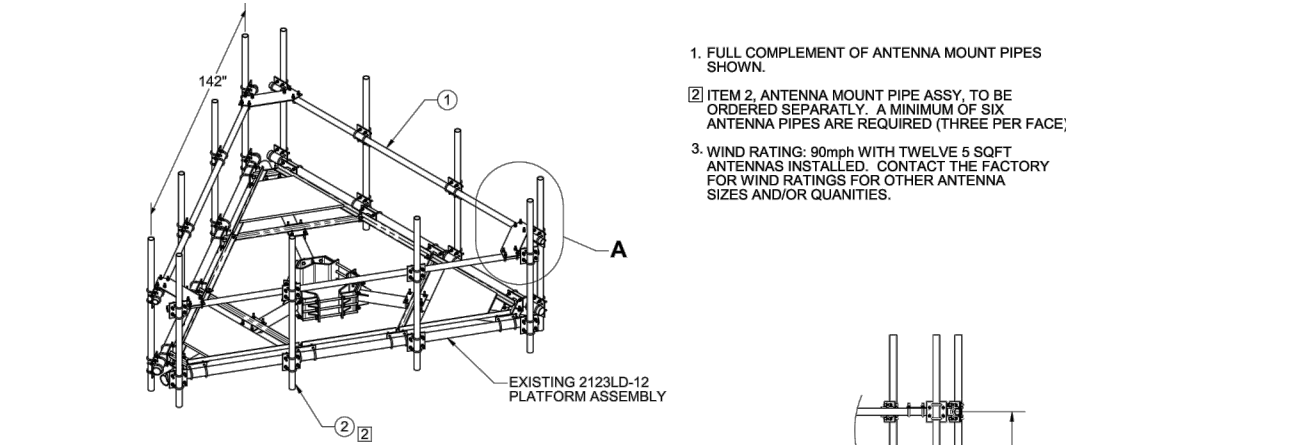

ITEM NO.	QTY.	PART NO.	DESCRIPTION
1	3	2125-150	PIPE, 2" (2.38" OD) SCHED 40 X 150" LG, GALV
2	6-12	2123LD-XHRMKTIT [2]	ANTENNA MOUNT PIPE ASSY, (2" (2.38" OD) SCHED 40 GALV)
3	3	7000-2123LD-14.7	CORNER BRACKET, 12FT PLATFORM
4	12	4499-4G	U-BOLT, 2" (2.38" OD) PIPE, GALV (1/2" DIA)
5	24	4650G	NUT, 1/2" HEX, A563 GALV
6	24	4754G	WASHER, 1/2" RGLR LOCK, GALV

3 HANDRAIL DETAIL
 SCALE: 1/4" = 1'-0"
 TRUE NORTH

- FULL COMPLEMENT OF ANTENNA MOUNT PIPES SHOWN.
- ITEM 2, ANTENNA MOUNT PIPE ASSY, TO BE ORDERED SEPARATELY. A MINIMUM OF SIX ANTENNA PIPES ARE REQUIRED (THREE PER FACE);
- WIND RATING: 90mph WITH TWELVE 5 SQFT ANTENNAS INSTALLED. CONTACT THE FACTORY FOR WIND RATINGS FOR OTHER ANTENNA SIZES AND/OR QUANTITIES.

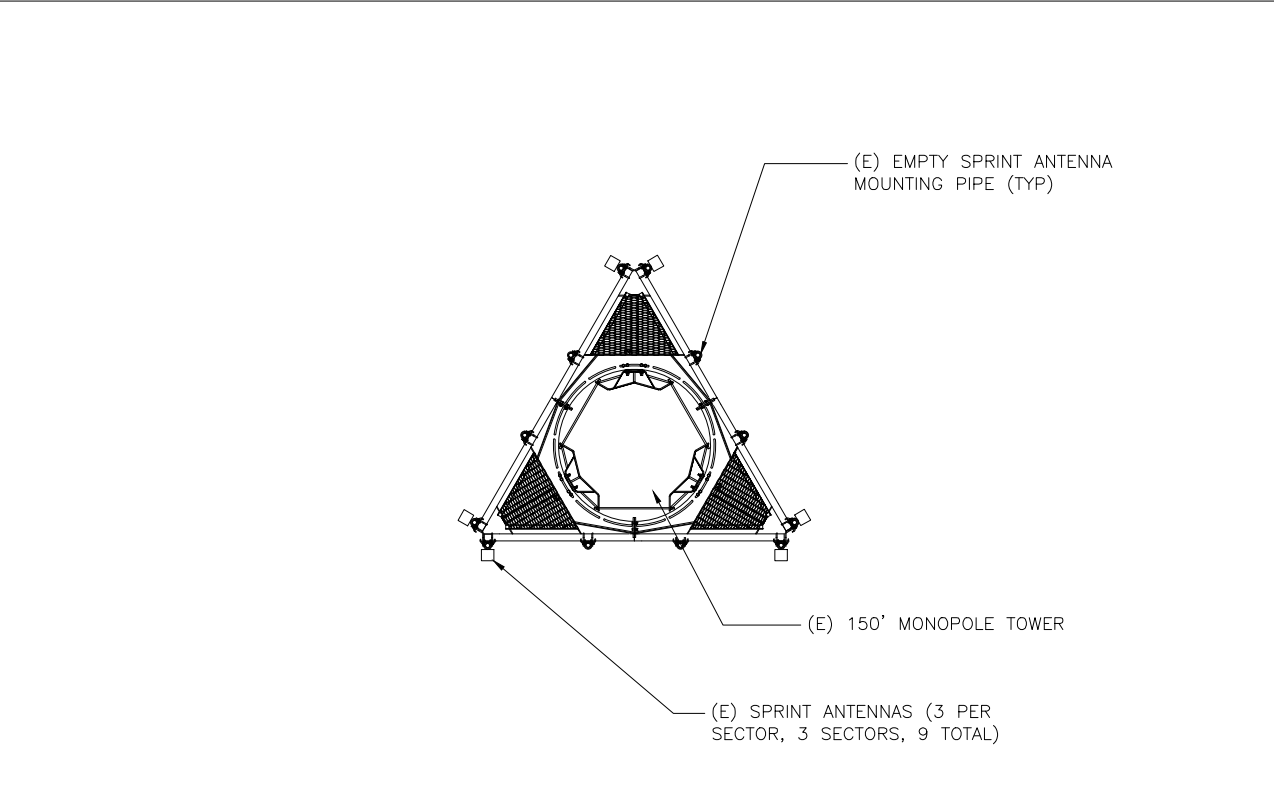
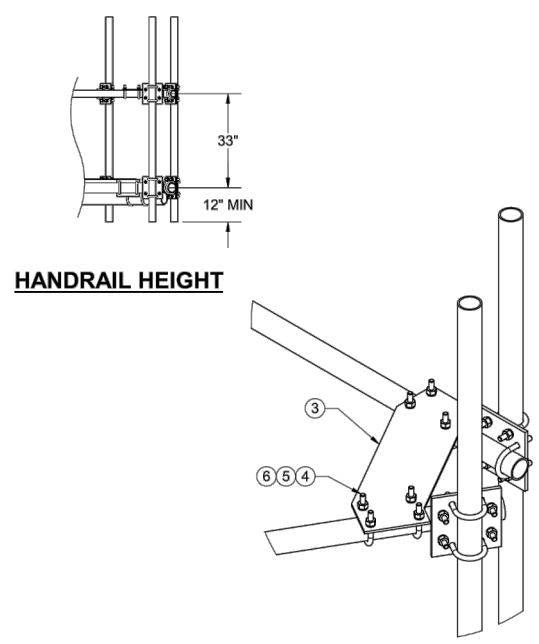

2 EXISTING ANTENNA PLAN
 SCALE: 1/4" = 1'-0"
 TRUE NORTH

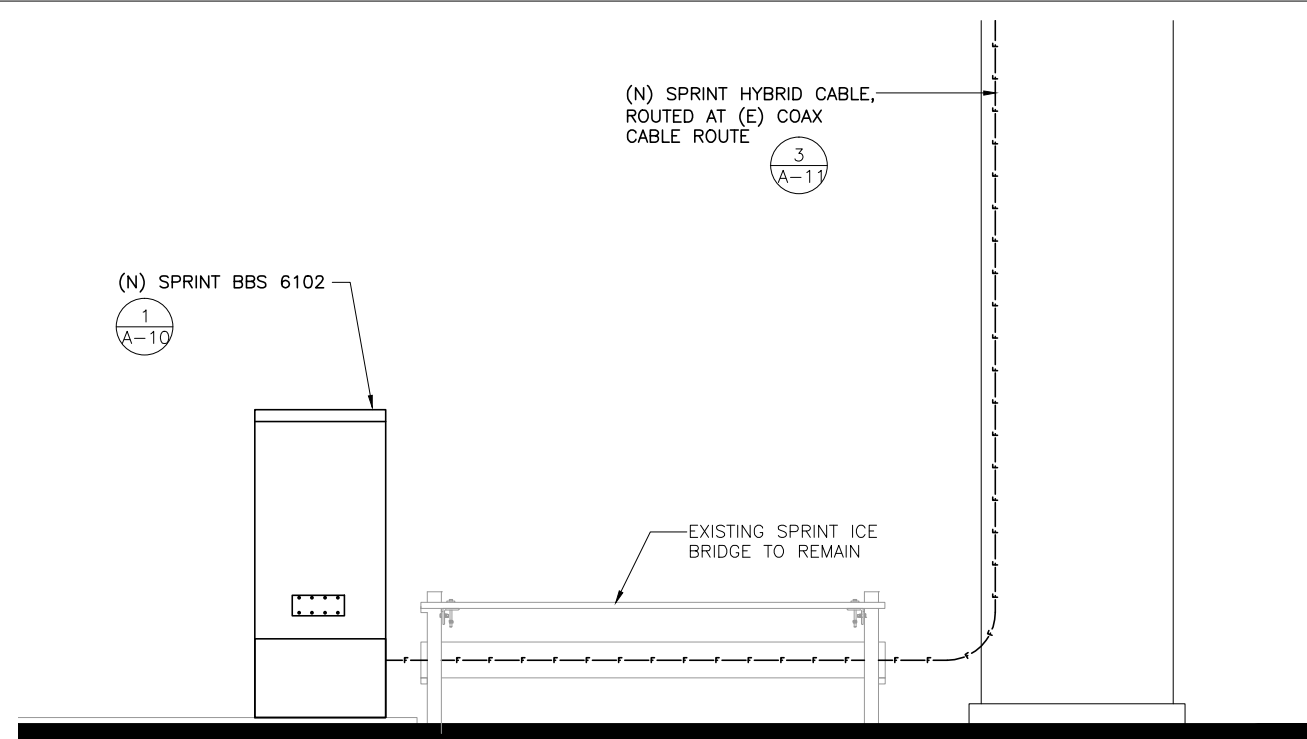

1 COAX RUN DIAGRAM
 SCALE: 1/2" = 1'-0"

PREPARED FOR:

1 INTERNATIONAL BOULEVARD
 SUITE #800
 MAHWAH, N.J. 07495

CONSULTANT:

POWDER RIVER
 Development Services, LLC
 100 E. SHENANGO STREET
 SHARPSVILLE, PA 16150
 724.962.5999
 www.powderriverdev.com
 PRDS PROJ.NO. 1181-081911

SITE NAME:
**SPRING LAKE
 FIRE STATION #43**

SITE NUMBER:
SA13XC135

SITE ADDRESS:
 2059 W. BITTERS ROAD
 SAN ANTONIO, TX 78248

STAMP:

DRAWN BY:	KE		
APPROVED BY:	G.W.C.		
DATE DRAWN:	09/07/11		
REVISION			
NO	DESCRIPTION	BY	DATE
△	SUBMISSION: 90% CD	KE	09/07/11
△	FINALS	TM	11/07/11
△	FINALS-REV1	TM	08/17/12

SHEET TITLE:
**ENLARGED ANTENNA
 PLANS**

SHEET NUMBER:
A-7

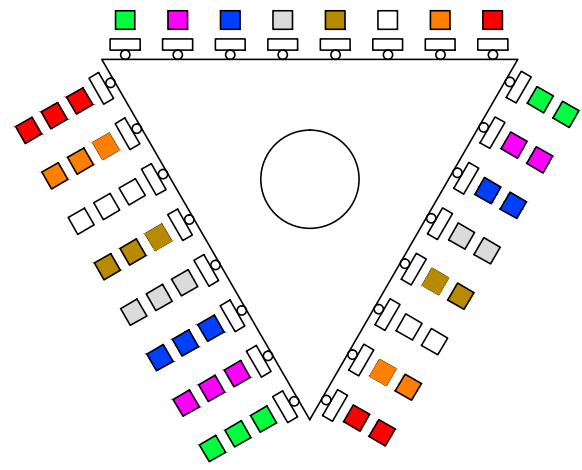

SECTOR LEGEND	TECHNOLOGY COLOR CODE
SECTOR 1 => 1 BAND	 IDEN
SECTOR 2 => 2 BAND	 CDMA
SECTOR 3 => 3 BAND	 WiMAX
SECTOR 4 => 4 BAND	
SECTOR 5 => 5 BAND	
SECTOR 6 => 6 BAND	

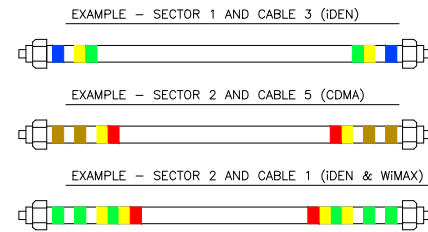

- COLOR BAND TO BE 2" WIDE ON MAIN LINE.
- SPACING TO BE 1" BETWEEN BANDS AND 2" BETWEEN LINE AND TECHNOLOGY BANDS. NO SPACE BETWEEN TECHNOLOGY COLOR BANDS.
- COLOR BAND ON JUMPERS 1" WIDE WITH 1" SPACE.
- START COLOR BANDS 2" BEYOND WEATHERPROOFING.
- START SECTOR COLOR NEXT TO END CONNECTOR.

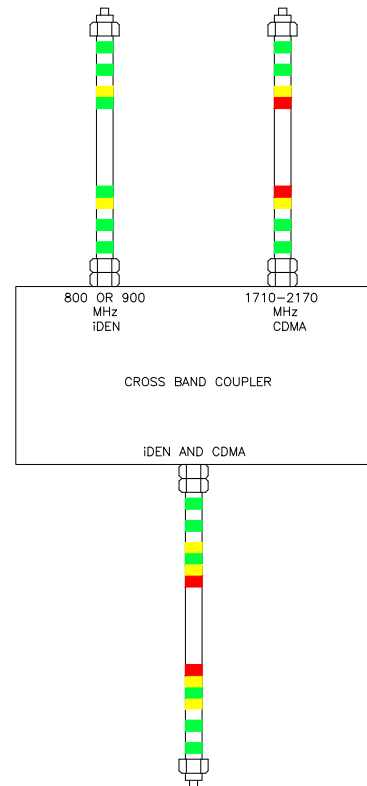

3 ANTENNA & CABLE COLOR CODE

SCALE: N.T.S.

TYPICAL COAX CABLE COLOR CODING SCHEME				
SECTOR	CABLE	FIRST RING	SECOND RING	THIRD RING
1 ALPHA	1	GREEN	NO TAPE	NO TAPE
1	2	BLUE	NO TAPE	NO TAPE
1	3	BROWN	NO TAPE	NO TAPE
1	4	WHITE	NO TAPE	NO TAPE
1	5	RED	NO TAPE	NO TAPE
1	6	GREY	NO TAPE	NO TAPE
1	7	PURPLE	NO TAPE	NO TAPE
1	8	ORANGE	NO TAPE	NO TAPE
2 BETA	1	GREEN	GREEN	NO TAPE
2	2	BLUE	BLUE	NO TAPE
2	3	BROWN	BROWN	NO TAPE
2	4	WHITE	WHITE	NO TAPE
2	5	RED	RED	NO TAPE
2	6	GREY	GREY	NO TAPE
2	7	PURPLE	PURPLE	NO TAPE
2	8	ORANGE	ORANGE	NO TAPE
3 GAMMA	1	GREEN	GREEN	GREEN
3	2	BLUE	BLUE	BLUE
3	3	BROWN	BROWN	BROWN
3	4	WHITE	WHITE	WHITE
3	5	RED	RED	RED
3	6	GREY	GREY	GREY
3	7	PURPLE	PURPLE	PURPLE
3	8	ORANGE	ORANGE	ORANGE

5 COAXIAL CABLE COLOR CODE

SCALE: N.T.S.

TECHNOLOGY COLOR CODE	FIRST RING	SECOND RING
IDEN	YELLOW	GREEN
CDMA	YELLOW	RED
WiMAX	YELLOW	BLUE

2 FREQUENCY COLOR CODE

SCALE: N.T.S.

4 NOT USED

SCALE: N.T.S.

1 NOT USED

SCALE: N.T.S.

PREPARED FOR:



1 INTERNATIONAL BOULEVARD
SUITE #800
MAHWAH, N.J. 07495

CONSULTANT:



POWDER RIVER

Development Services, LLC

100 E. SHENANGO STREET
SHARPSVILLE, PA 16150

724.962.5999

www.powderriverdev.com

PRDS PROJ.NO. 1181-081911

SITE NAME:

**SPRING LAKE
FIRE STATION #43**

SITE NUMBER:

SA13XC135

SITE ADDRESS:

2059 W. BITTERS ROAD
SAN ANTONIO, TX 78248

STAMP:

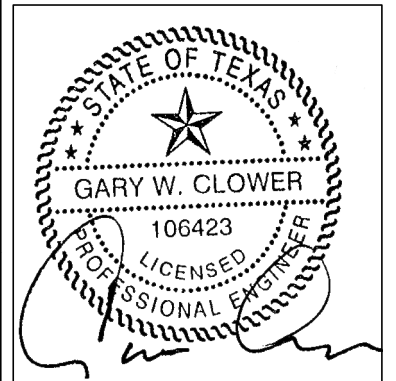

DRAWN BY: KE

APPROVED BY: G.W.C.

DATE DRAWN: 09/07/11

REVISION

NO	DESCRIPTION	BY	DATE
△	SUBMISSION: 90% CD	KE	09/07/11
△	FINALS	TM	11/07/11
△	FINALS-REV1	TM	08/17/12

SHEET TITLE:

(E) COLOR CODING

SHEET NUMBER:

A-8

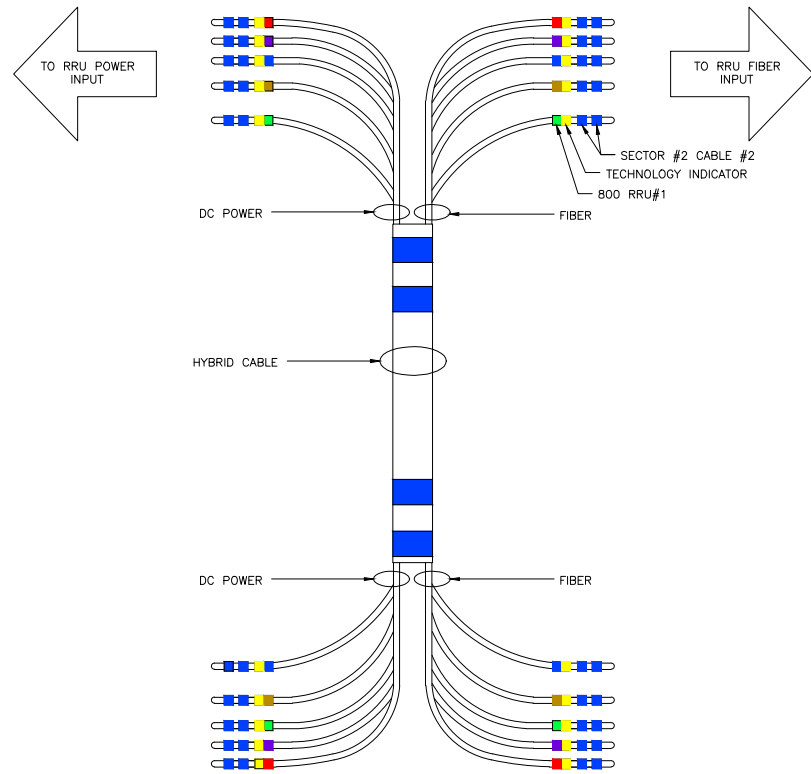

5 HYBRID CABLE COLOR CODE
SCALE: N.T.S.

TYPICAL COAX CABLE COLOR CODING SCHEME				
SECTOR	CABLE	FIRST RING	SECOND RING	THIRD RING
1 ALPHA	1	GREEN	NO TAPE	NO TAPE
1	2	BLUE	NO TAPE	NO TAPE
1	3	BROWN	NO TAPE	NO TAPE
1	4	WHITE	NO TAPE	NO TAPE
1	5	RED	NO TAPE	NO TAPE
1	6	SLATE	NO TAPE	NO TAPE
1	7	PURPLE	NO TAPE	NO TAPE
1	8	ORANGE	NO TAPE	NO TAPE
2 BETA	1	GREEN	GREEN	NO TAPE
2	2	BLUE	BLUE	NO TAPE
2	3	BROWN	BROWN	NO TAPE
2	4	WHITE	WHITE	NO TAPE
2	5	RED	RED	NO TAPE
2	6	SLATE	SLATE	NO TAPE
2	7	PURPLE	PURPLE	NO TAPE
2	8	ORANGE	ORANGE	NO TAPE
3 GAMMA	1	GREEN	GREEN	GREEN
3	2	BLUE	BLUE	BLUE
3	3	BROWN	BROWN	BROWN
3	4	WHITE	WHITE	WHITE
3	5	RED	RED	RED
3	6	SLATE	SLATE	SLATE
3	7	PURPLE	PURPLE	PURPLE
3	8	ORANGE	ORANGE	ORANGE

4 COAXIAL CABLE COLOR CODE
SCALE: N.T.S.

TECHNOLOGY COLOR CODE	FIRST RING	SECOND RING
800 #1	YELLOW	GREEN
1900 #1	YELLOW	RED
1900 #2	YELLOW	BROWN
RESERVED	YELLOW	BLUE
RESERVED	YELLOW	SLATE
RESERVED	YELLOW	ORANGE
RESERVED	YELLOW	WHITE
1600 #1	YELLOW	PURPLE

2 FREQUENCY COLOR CODE
SCALE: N.T.S.

3 NOT USED
SCALE: N.T.S.

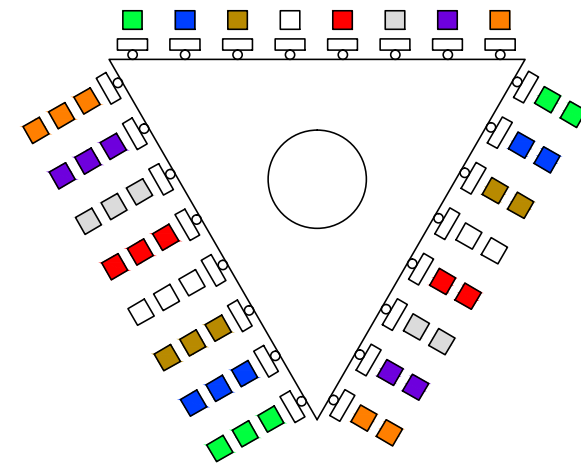

SECTOR LEGEND
 SECTOR 1 => 1 BAND
 SECTOR 2 => 2 BAND
 SECTOR 3 => 3 BAND
 SECTOR 4 => 4 BAND
 SECTOR 5 => 5 BAND
 SECTOR 6 => 6 BAND

TECHNOLOGY COLOR CODE
 IDEN: Green
 CDMA: Red
 WIMAX: Blue

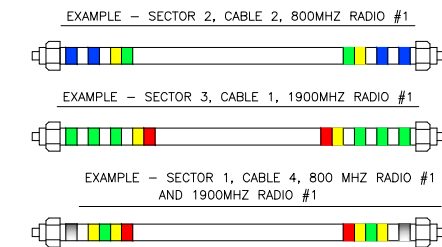

- COLOR BAND TO BE 2" WIDE ON MAIN LINE.
- SPACING TO BE 1" BETWEEN BANDS AND 2" BETWEEN LINE AND TECHNOLOGY BANDS. NO SPACE BETWEEN TECHNOLOGY COLOR BANDS.
- COLOR BAND ON JUMPERS 1" WIDE WITH 1" SPACE.
- START COLOR BANDS 2" BEYOND WEATHERPROOFING.
- START SECTOR COLOR NEXT TO END CONNECTOR.

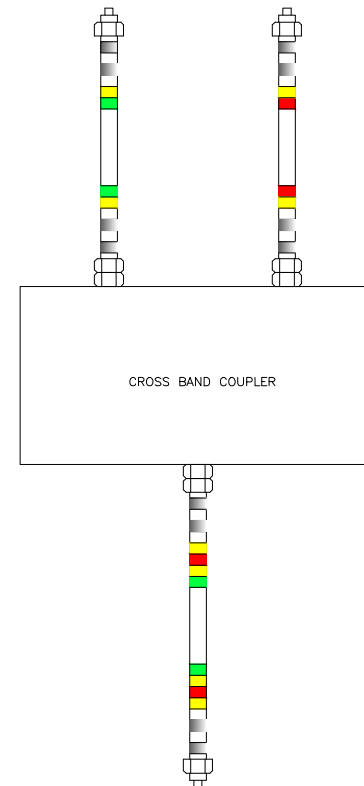

1 ANTENNA & CABLE COLOR CODE
SCALE: N.T.S.

PREPARED FOR:



1 INTERNATIONAL BOULEVARD
SUITE #800
MAHWAH, N.J. 07495

CONSULTANT:



POWDER RIVER

Development Services, LLC

100 E. SHENANGO STREET
SHARPSVILLE, PA 16150

724.962.5999

www.powderriverdev.com

PRDS PROJ.NO. 1181-081911

SITE NAME:

**SPRING LAKE
FIRE STATION #43**

SITE NUMBER:

SA13XC135

SITE ADDRESS:

2059 W. BITTERS ROAD
SAN ANTONIO, TX 78248

STAMP:

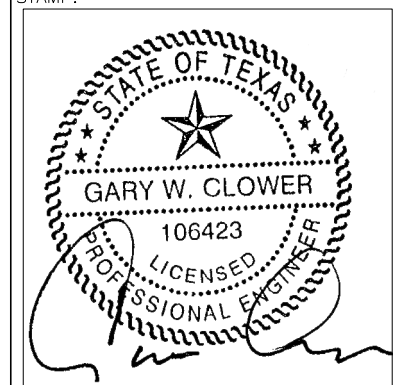

DRAWN BY: KE
APPROVED BY: G.W.C.
DATE DRAWN: 09/07/11

REVISION			
NO	DESCRIPTION	BY	DATE
△	SUBMISSION: 90% CD	KE	09/07/11
△	FINALS	TM	11/07/11
△	FINALS-REV1	TM	08/17/12

SHEET TITLE:
(N) COLOR CODING

SHEET NUMBER:
A-9

MANUFACTURER: ERICSSON
 MODEL: GLOBAL BASE FRAME (GBF) 6102
 WEIGHT: <44.0 LBS.

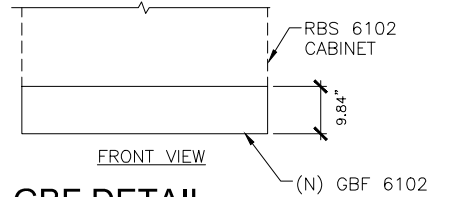
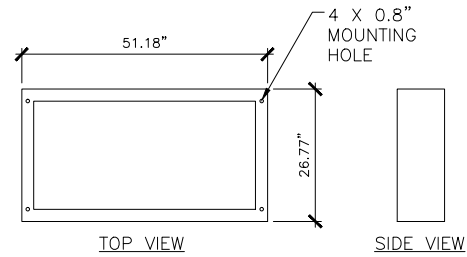

5 GBF DETAIL
 SCALE: N.T.S.

4

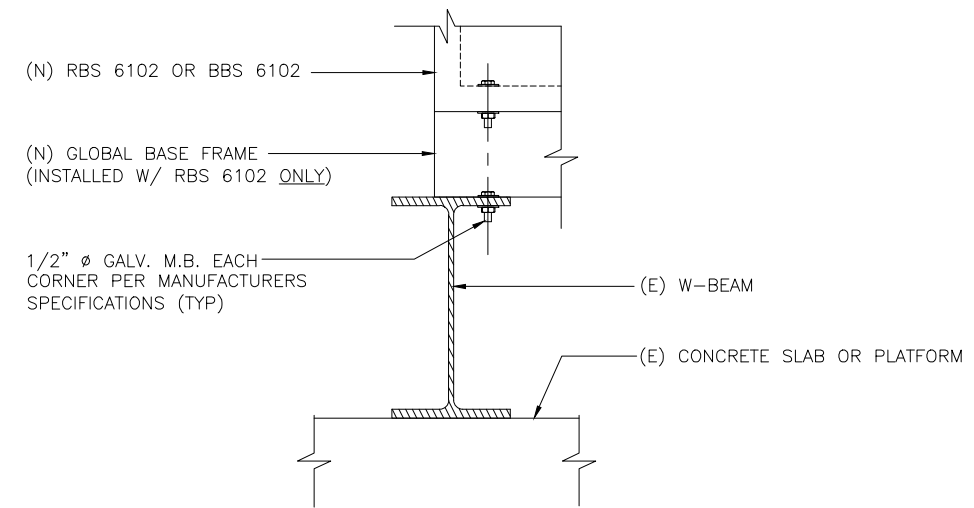

3 CABINET MOUNTING DETAIL
 N.T.S.

PREPARED FOR:



1 INTERNATIONAL BOULEVARD
 SUITE #800
 MAHWAH, N.J. 07495

CONSULTANT:



POWDER RIVER

Development Services, LLC

100 E. SHENANGO STREET
 SHARPSVILLE, PA 16150

724.962.5999

www.powderriverdev.com

PRDS PROJ.NO. 1181-081911

SITE NAME:

**SPRING LAKE
 FIRE STATION #43**

SITE NUMBER:

SA13XC135

SITE ADDRESS:

2059 W. BITTERS ROAD
 SAN ANTONIO, TX 78248

STAMP:

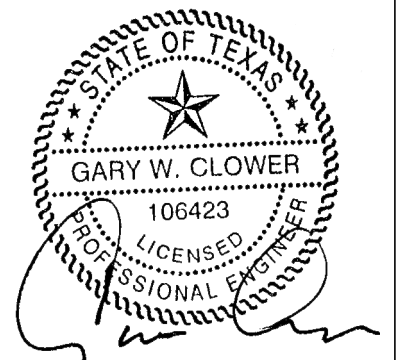

ERICSSON RBS 6102	
DIMENSIONS	51.18"W x 27.56"D x *66.93"H
WEIGHT	**771.62 LBS.
MINIMUM CLEARANCES	
FRONT	27.56"
SIDES	1.97"
REAR	7.87"

*HEIGHT SHOWN ON THE TABLE INCLUDES GLOBAL BASE FRAME, PROVIDED BY ERICSSON.

**WEIGHT SHOWN ON THE TABLE INCLUDES GLOBAL BASE FRAME, PROVIDED BY ERICSSON

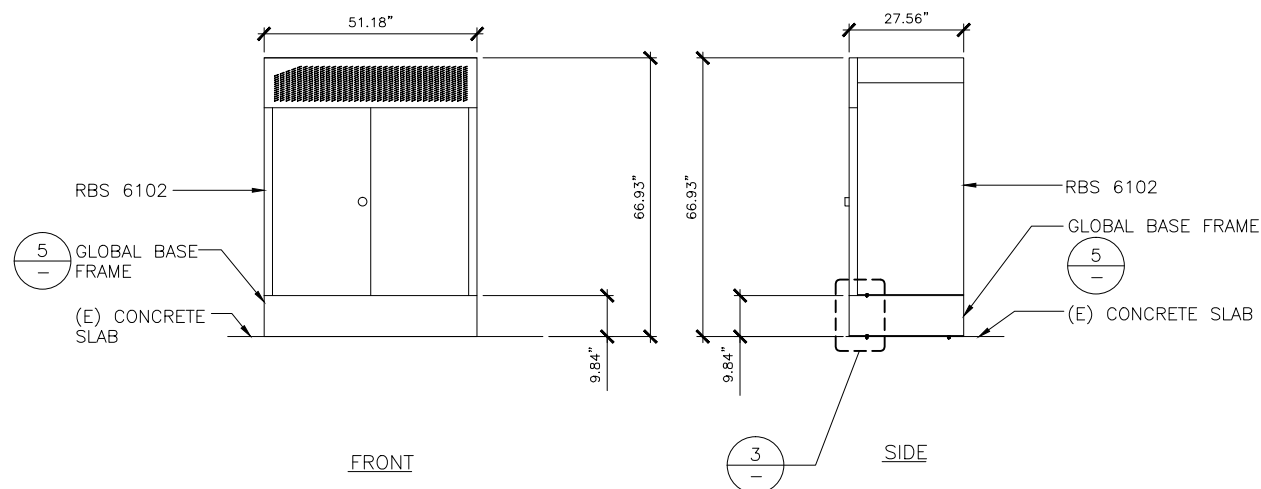

2 RBS 6102
 SCALE: N.T.S.

ERICSSON BBS 6102	
DIMENSIONS	51.18"W x 32.68"D x 57.28"H
WEIGHTS	*449.74 - 568.79 LBS. **491.63 - 654.77 LBS.
MINIMUM CLEARANCES	
FRONT	31.00"
SIDES	6.00"
REAR	6.00"

*WEIGHT SHOWN ON THE TABLE INCLUDES AGM BATTERIES

**WEIGHT SHOWN ON THE TABLE INCLUDES OPzV BATTERIES

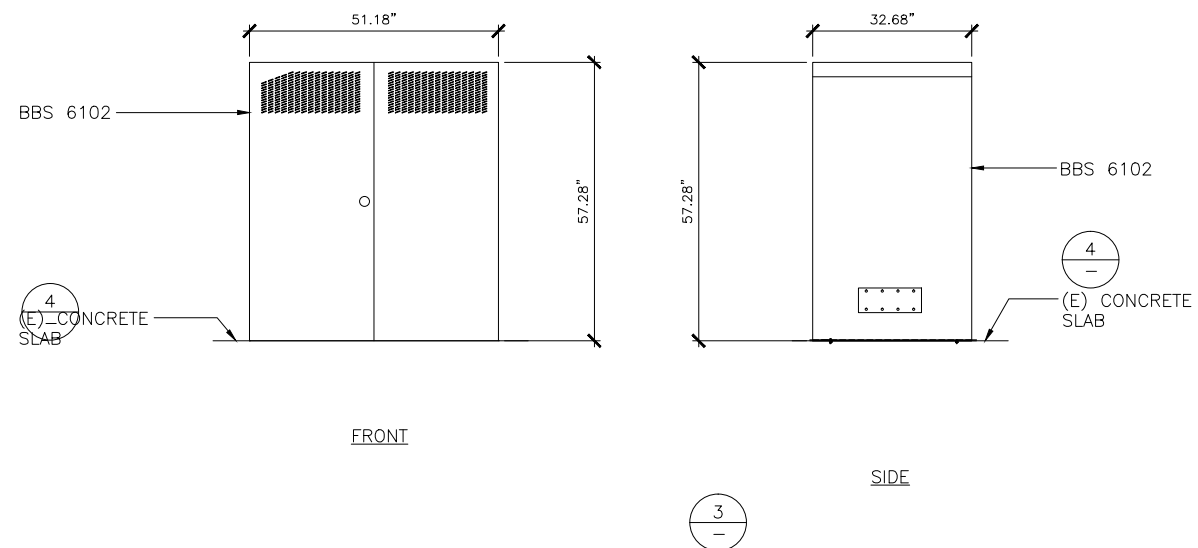

1 BBS 6102
 SCALE: N.T.S.

DRAWN BY:	KE
APPROVED BY:	G.W.C.
DATE DRAWN:	09/07/11

REVISION			
NO	DESCRIPTION	BY	DATE
△	SUBMISSION: 90% CD	KE	09/07/11
△	FINALS	TM	11/07/11
△	FINALS-REV1	TM	08/17/12

SHEET TITLE:
DETAILS

SHEET NUMBER:
A-10

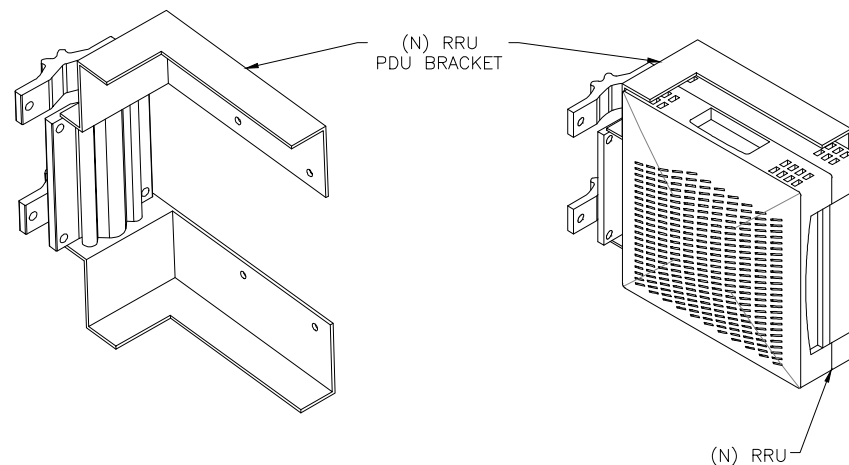
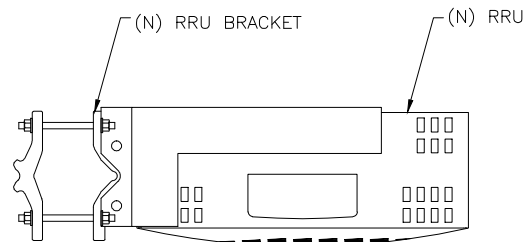
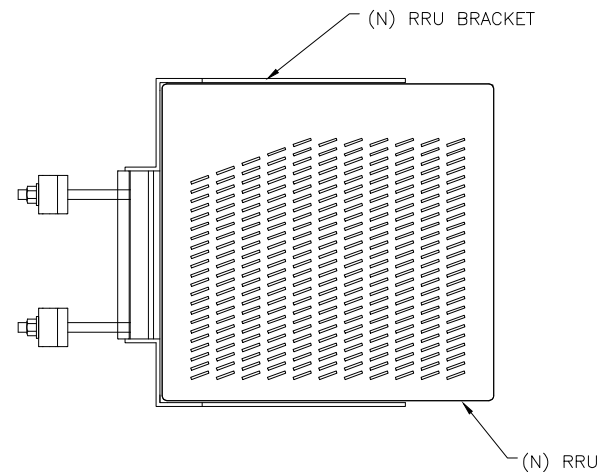

5 RRU MOUNTING BRACKET
SCALE: N.T.S.

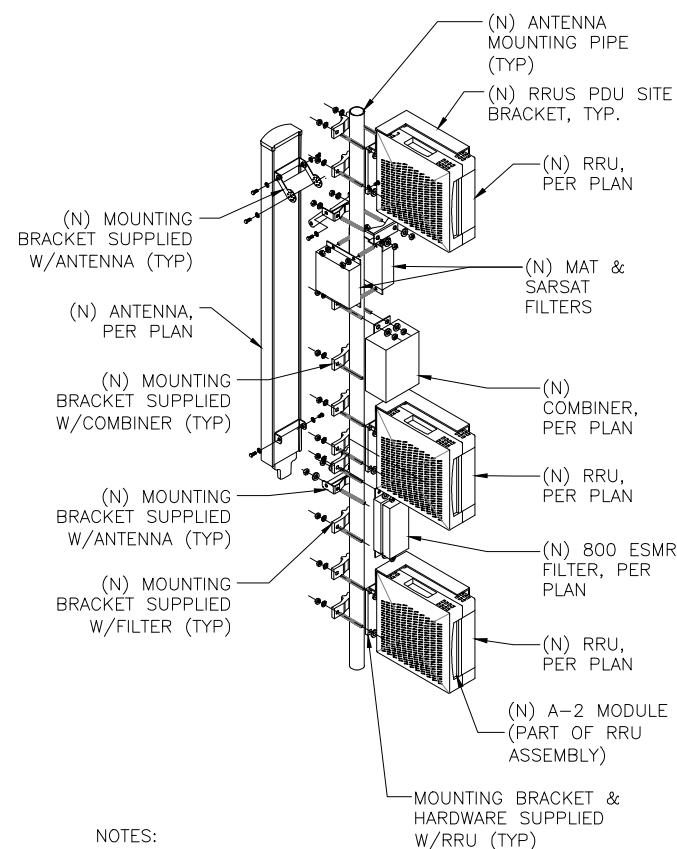

NOTES:
 (N) COMBINER SHALL BE SECURELY U-BOLTED TO (N) ANTENNA MOUNTING PIPE ADJACENT TO (N) RRUS. (2) PER SECTOR - REFER TO RFDS.
 (N) FILTERS SHALL BE SECURELY U-BOLTED TO (N) ANTENNA MOUNTING PIPE ADJACENT TO (N) RRUS. (6) PER SECTOR - REFER TO RFDS.

2 FINAL MOUNT DESIGN
SCALE: N.T.S.



CABLE	GAUGE	OD (IN)	MIN. BEND RADIUS (IN)	WEIGHT (LBS/FT)
5 POWER AND 6 FIBER PAIRS	#8 AWG	1.17	14.03	.954

4 NEW MLE HYBRID CABLE
SCALE: N.T.S.

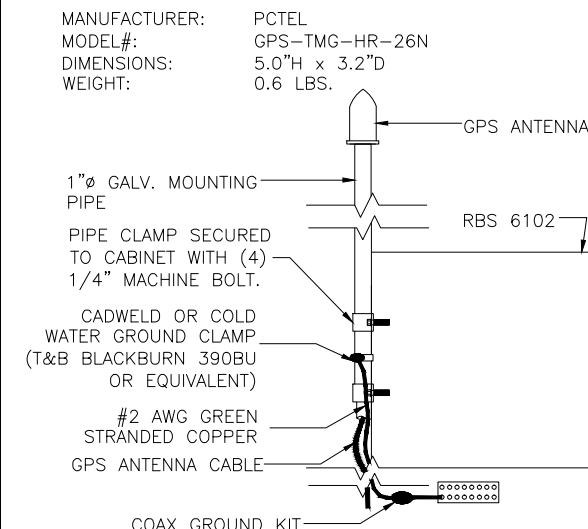

3 GPS ANTENNA
SCALE: N.T.S.

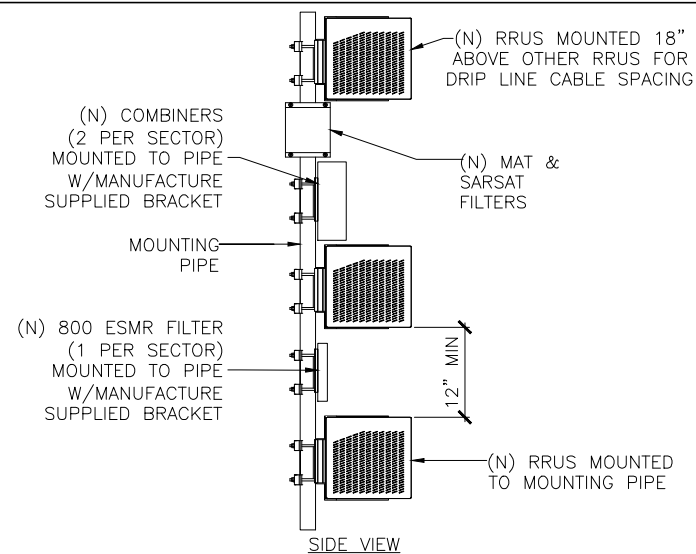

1 RRU PIPE MOUNT SPACING
SCALE: N.T.S.

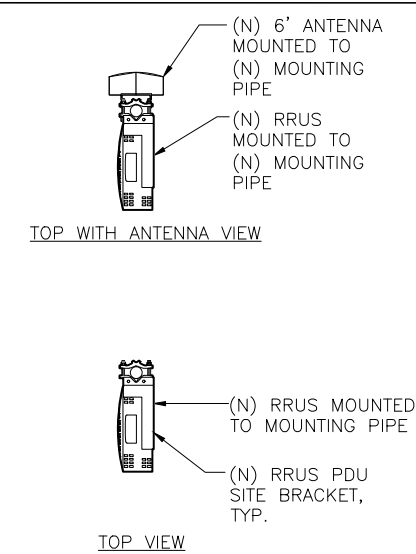
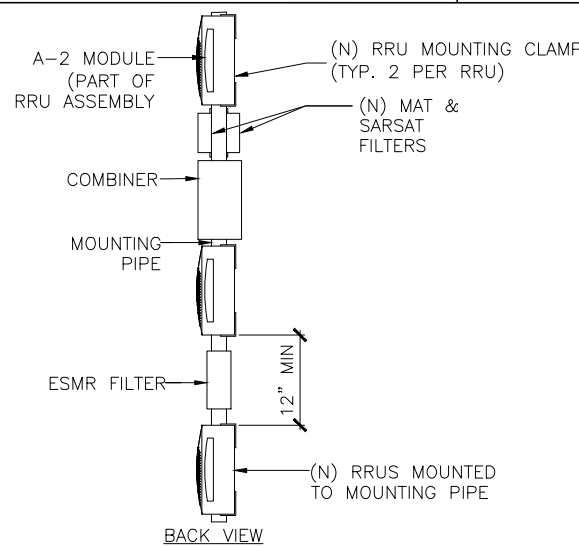

MANUFACTURER: PCTEL
 MODEL#: GPS-TMG-HR-26N
 DIMENSIONS: 5.0"H x 3.2"D
 WEIGHT: 0.6 LBS.

1"Ø GALV. MOUNTING PIPE
 PIPE CLAMP SECURED TO CABINET WITH (4) 1/4" MACHINE BOLT.
 CADWELD OR COLD WATER GROUND CLAMP (T&B BLACKBURN 390BU OR EQUIVALENT)
 #2 AWG GREEN STRANDED COPPER
 GPS ANTENNA CABLE
 COAX GROUND KIT

PREPARED FOR:



1 INTERNATIONAL BOULEVARD
 SUITE #800
 MAHWAH, N.J. 07495

CONSULTANT:



POWDER RIVER

Development Services, LLC

100 E. SHENANGO STREET
 SHARPSVILLE, PA 16150

724.962.5999

www.powderriverdev.com

PRDS PROJ.NO. 1181-081911

SITE NAME:
**SPRING LAKE
 FIRE STATION #43**

SITE NUMBER:
SA13XC135

SITE ADDRESS:
 2059 W. BITTERS ROAD
 SAN ANTONIO, TX 78248

STAMP:

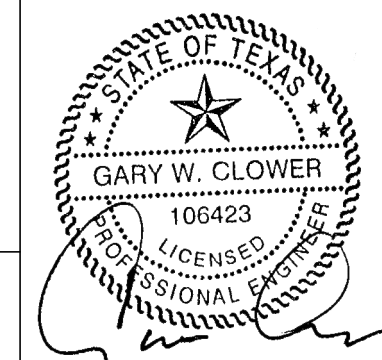

DRAWN BY:	KE		
APPROVED BY:	G.W.C.		
DATE DRAWN:	09/07/11		
REVISION			
NO	DESCRIPTION	BY	DATE
△	SUBMISSION: 90% CD	KE	09/07/11
△	FINALS	TM	11/07/11
△	FINALS-REV1	TM	08/17/12

SHEET TITLE:
DETAILS

SHEET NUMBER:
A-11

3 DETAIL
SCALE: 1/2" = 1'-0"

2 DETAIL
SCALE: 1/2" = 1'-0"

ELECTRICAL NOTES:

1. ALL ELECTRICAL WORK SHALL CONFORM TO THE LATEST EDITION OF THE NATIONAL ELECTRICAL CODE (N.E.C.), AND APPLICABLE LOCAL CODES.
2. GROUNDING SHALL COMPLY WITH ARTICLE 250 OF NATIONAL ELECTRICAL CODE.
3. ALL ELECTRICAL ITEMS SHALL BE U.L. APPROVED OR LISTED
4. ALL WIRES SHALL BE AWG MIN #12 THHN COPPER UNLESS NOTED.
5. CONDUCTORS SHALL BE INSTALLED IN SCHEDULE 40 PVC CONDUIT UNLESS NOTED OTHERWISE.
6. LABEL SPRINT SERVICE DISCONNECT SWITCH AND PPC CABINET WITH ENGRAVED LAMICOID LABELS, LETTERS 1" IN HEIGHT.
7. ROUTE GROUNDING CONDUCTORS ALONG THE SHORTEST AND STRAIGHTEST PATH POSSIBLE. BEND GROUNDING LEADS WITH A MINIMUM 8" RADIUS.
8. ENGAGE AN INDEPENDENT TESTING FIRM TO TEST AND VERIFY THAT RESISTANCE DOES NOT EXCEED 5 OHMS TO GROUND. TEST GROUND RING RESISTANCE PRIOR TO MAKING FINAL GROUND CONNECTIONS TO INFRASTRUCTURE AND EQUIPMENT. GROUNDING AND OTHER OPERATIONAL TESTING SHALL BE WITNESSED BY SPRINTS REPRESENTATIVE.
9. PROVIDE PULL BOXES AND JUNCTION BOXES WHERE REQUIRED SO THAT CONDUIT BENDS DO NOT EXCEED 360°.
10. OBTAIN PERMITS AND PAY FEES RELATED TO ELECTRICAL WORK PERFORMED ON THIS PROJECT. DELIVER COPIES OF ALL PERMITS TO SPRINT REPRESENTATIVE.
11. SCHEDULE AND ATTEND INSPECTIONS RELATED TO ELECTRICAL WORK REQUIRED BY JURISDICTION HAVING AUTHORITY. CORRECT AND PAY FOR ANY WORK REQUIRED TO PASS ANY FAILED INSPECTION.
12. RELINE AS-BUILTS ARE TO BE DELIVERED TO SPRINT REPRESENTATIVE.
13. PROVIDE TWO COPIES OF OPERATION AND MAINTENANCE MANUALS IN THREE-RING BINDER.
14. FURNISH AND INSTALL THE COMPLETE ELECTRICAL SERVICE, TELCO CONDUIT AND THE COMPLETE GROUNDING SYSTEM.
15. ALL WORK SHALL BE PERFORMED IN STRICT ACCORDANCE WITH ALL APPLICABLE BUILDING CODES AND LOCAL ORDINANCES, INSTALLED IN A NEAT MANNER, AND SHALL BE SUBJECT TO APPROVAL BY SPRINT REPRESENTATIVE.
16. CONDUCT A PRE-CONSTRUCTION SITE VISIT AND VERIFY EXISTING SITE CONDITIONS AFFECTING THIS WORK. REPORT ANY OMISSIONS OR DISCREPANCIES FOR CLARIFICATION PRIOR TO THE START OF CONSTRUCTION.
17. PROTECT ADJACENT STRUCTURES AND FINISHES FROM DAMAGE. REPAIR TO ORIGINAL CONDITION ANY DAMAGED AREA.
18. REMOVE DEBRIS ON A DAILY BASIS. DEBRIS NOT REMOVED IN A TIMELY FASHION WILL BE REMOVED BY OTHERS AND THE RESPONSIBLE SUBCONTRACTOR SHALL BE CHARGED ACCORDINGLY. REMOVAL OF DEBRIS SHALL BE COORDINATED WITH THE OWNER'S REPRESENTATIVE. DEBRIS SHALL BE REMOVED FROM THE PROPERTY AND DISPOSED OF LEGALLY.
19. UPON COMPLETION OF WORK, THE SITE SHALL BE CLEAN AND FREE OF DUST AND FINGERPRINTS.
20. PRIOR TO ANY TRENCHING, CONTACT LOCAL UTILITY TO VERIFY LOCATION OF ANY EXISTING BURIED SERVICE CONDUITS.
21. DOCUMENT GROUND RING INSTALLATION AND CONNECTIONS TO IT WITH PHOTOGRAPHS PRIOR TO BACKFILLING SITE. PRESENT PHOTO ARCHIVE AT SITE "PUNCH LIST" WALK TO SPRINT'S REPRESENTATIVE.

PREPARED FOR:



1 INTERNATIONAL BOULEVARD
SUITE #800
MAHWAH, N.J. 07495

CONSULTANT:



POWDER RIVER

Development Services, LLC

100 E. SHENANGO STREET
SHARPSVILLE, PA 16150

724.962.5999

www.powderriverdev.com

PRDS PROJ.NO. 1181-081911

SITE NAME:

**SPRING LAKE
FIRE STATION #43**

SITE NUMBER:

SA13XC135

SITE ADDRESS:

2059 W. BITTERS ROAD
SAN ANTONIO, TX 78248

STAMP:

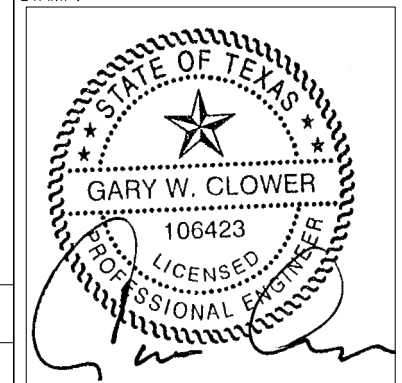

ABBREVIATIONS

A	AMPERE
AF	AMPERE FRAME
AGB	ANTENNA GROUND BAR
C	CONDUIT
G	GROUND
KWH	KILOWATT HOUR
MGB	MASTER GROUND BAR
MCB	MAIN CIRCUIT BREAKER
PVC	POLYVINYL CHLORIDE
P	POLE
RMC	RIGID METAL CONDUIT
SN	SOLID NEUTRAL
V	VOLT
W	WIRE
Ø	PHASE

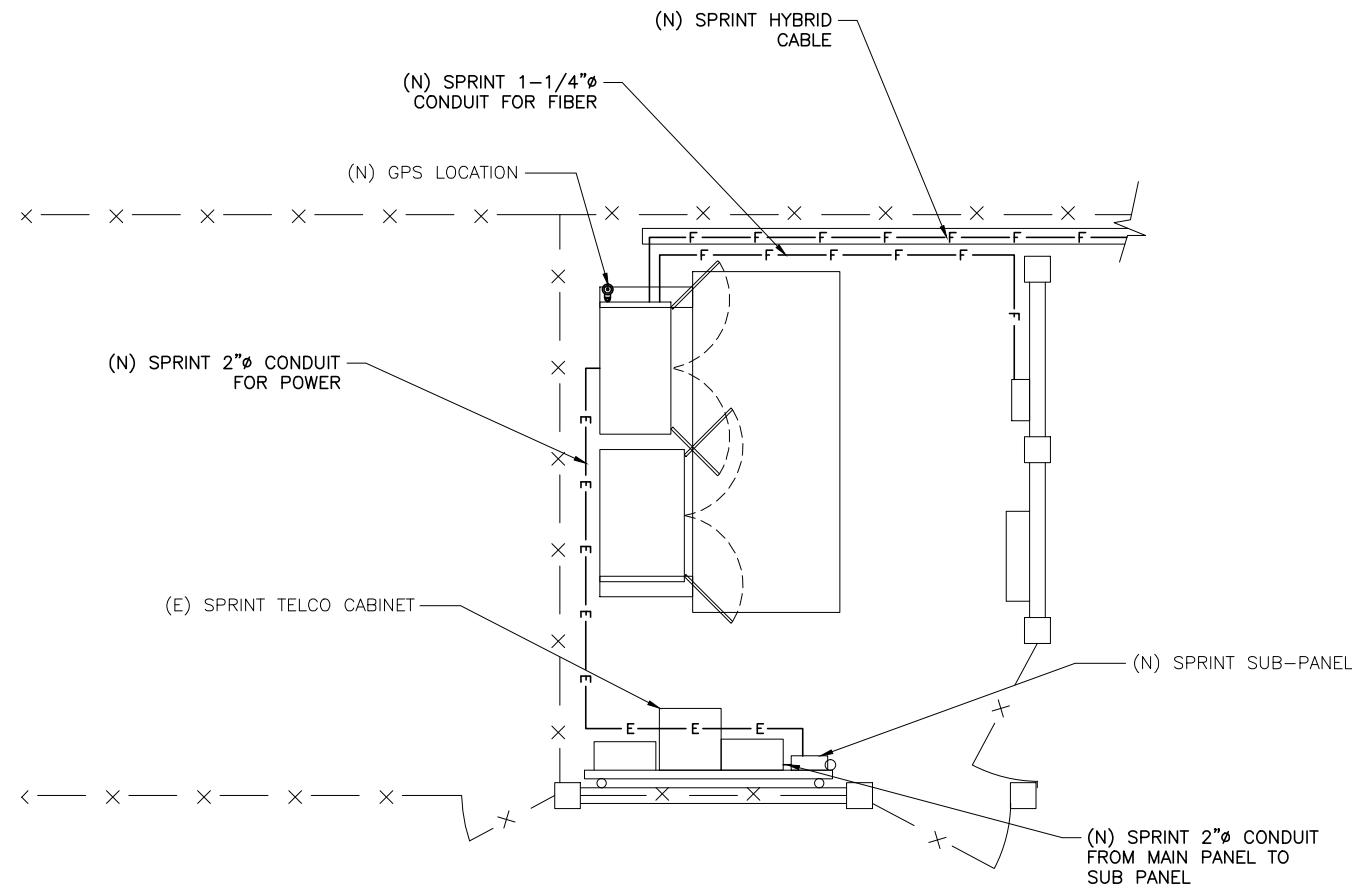

1 ELECTRICAL / TELCO SITE PLAN

FULL SIZE PLOT: SCALE: 3/8" = 1'-0"
HALF SIZE PLOT: SCALE: 3/16" = 1'-0"

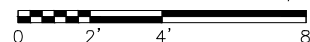

LEGEND:

KILOWATT HOUR METER



E

T

G

DRAWN BY: KE

APPROVED BY: G.W.C.

DATE DRAWN: 09/07/11

REVISION

NO	DESCRIPTION	BY	DATE
1	SUBMISSION: 90% CD	KE	09/07/11
2	FINALS	TM	11/07/11
3	FINALS-REV1	TM	08/17/12

SHEET TITLE:
**ELECTRICAL PLAN &
DETAILS**

SHEET NUMBER:

E-1

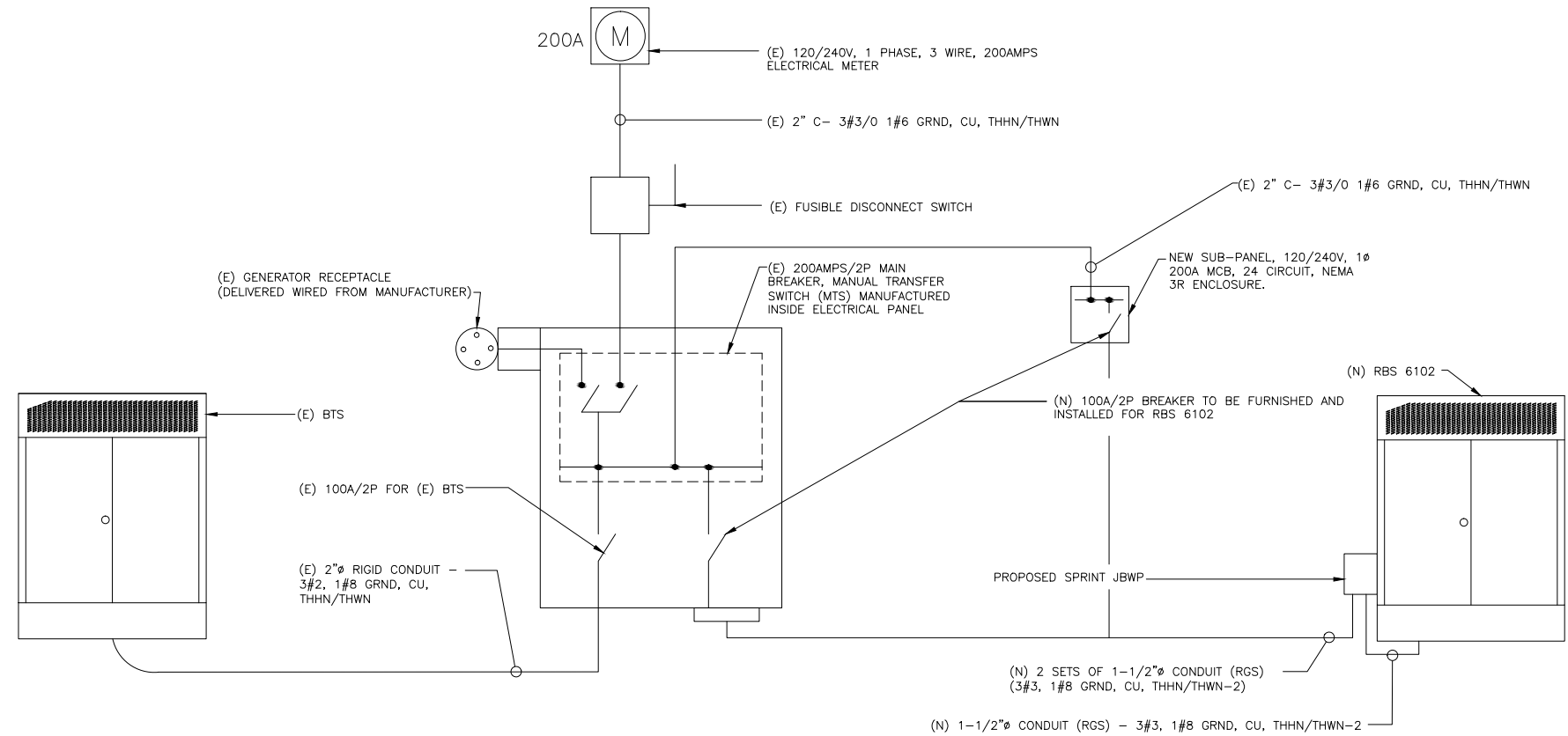

3 ELECTRICAL & TELCO ONE-LINE RISER DIAGRAM
N.T.S.

120/240V, 1Ø, 3W
200A BUS, 22 KAIC

FINAL PANEL "A" SCHEDULE

CKT. NO.	CKT AMPS	BKR POLES	DESCRIPTION	LOAD (WATTS)		DESCRIPTION	CKT AMPS	BKR POLES	CKT. NO.
				L1	L2				
1	100	2	SPARE	---	---	(E) SURGE PROTECTOR (TVSS)	60	2	2
3				---	---				4
5	100	2	(N) RBS 6102	5,800	---	SPACE		1	6
7				---	5,800	SPACE		1	8
9	20	1	(E) SERVICE LIGHTS	900	---	(E) TELCO CABINET	20	1	10
11	10	1	(E) RECP OLD TELCO	---	360	(E) OUTSIDE RECP	20	1	12
PHASE TOTAL (WATTS)				6,700	6,160				
TOTAL CONNECTED (WATTS)				12,860					
25% OF LARGEST CONTINUOUS LOAD (LCL)				3,215					
TOTAL LOAD (WATTS)				16,075					
TOTAL LOAD (AMPS)				70A					

2 PANEL SCHEDULE-PERMANENT
N.T.S.

PREPARED FOR:



1 INTERNATIONAL BOULEVARD
SUITE #800
MAHWAH, N.J. 07495

CONSULTANT:



POWDER RIVER

Development Services, LLC

100 E. SHENANGO STREET
SHARPSVILLE, PA 16150

724.962.5999

www.powderriverdev.com

PRDS PROJ.NO. 1181-081911

SITE NAME:

**SPRING LAKE
FIRE STATION #43**

SITE NUMBER:

SA13XC135

SITE ADDRESS:

2059 W. BITTERS ROAD
SAN ANTONIO, TX 78248

STAMP:



DRAWN BY: KE

APPROVED BY: G.W.C.

DATE DRAWN: 09/07/11

REVISION

NO	DESCRIPTION	BY	DATE
1	△ SUBMISSION: 90% CD	KE	09/07/11
2	△ FINALS	TM	11/07/11
3	△ FINALS-REV1	TM	08/17/12

SHEET TITLE:
**POWER/TELCO
DIAGRAMS**

SHEET NUMBER:

E-2

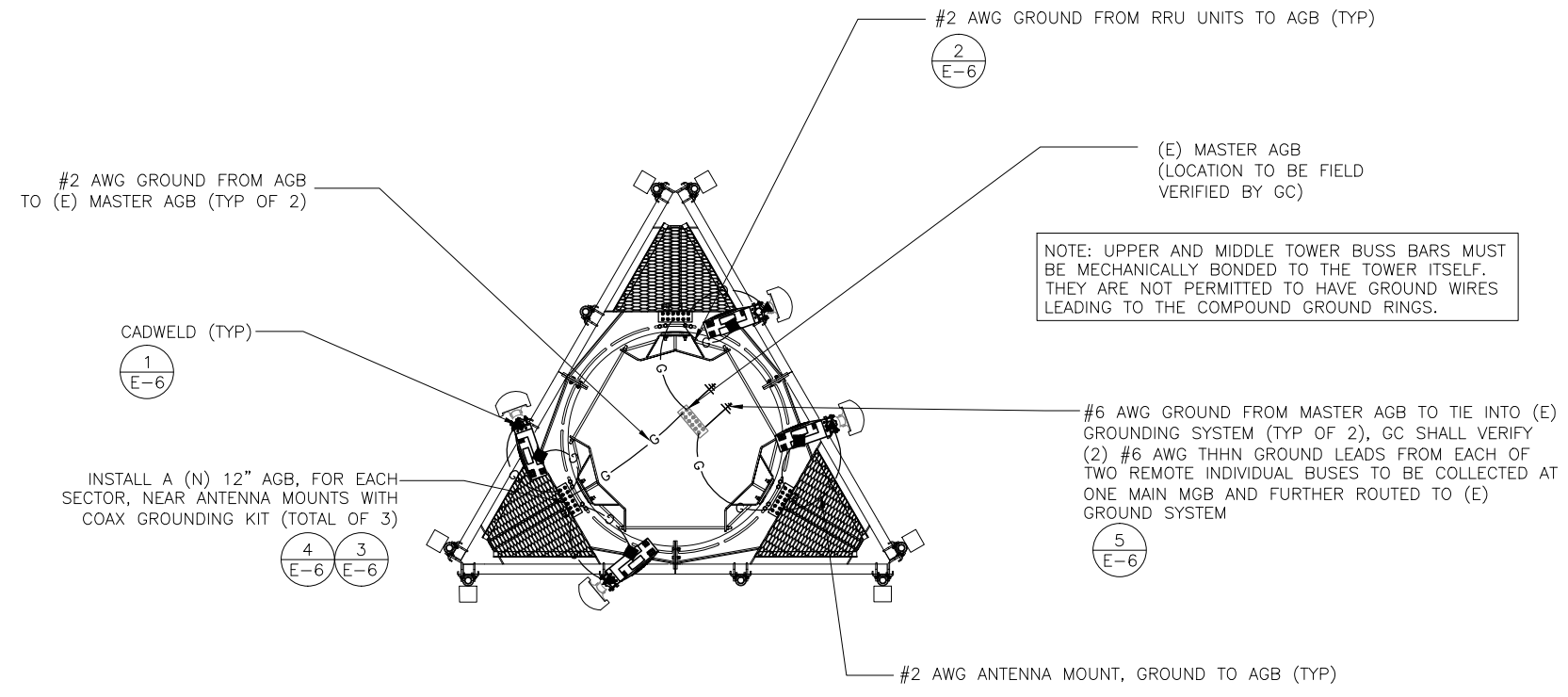

2 ANTENNA GROUNDING PLAN (FINAL)
 SCALE: 3/8" = 1'-0"
 TRUE NORTH

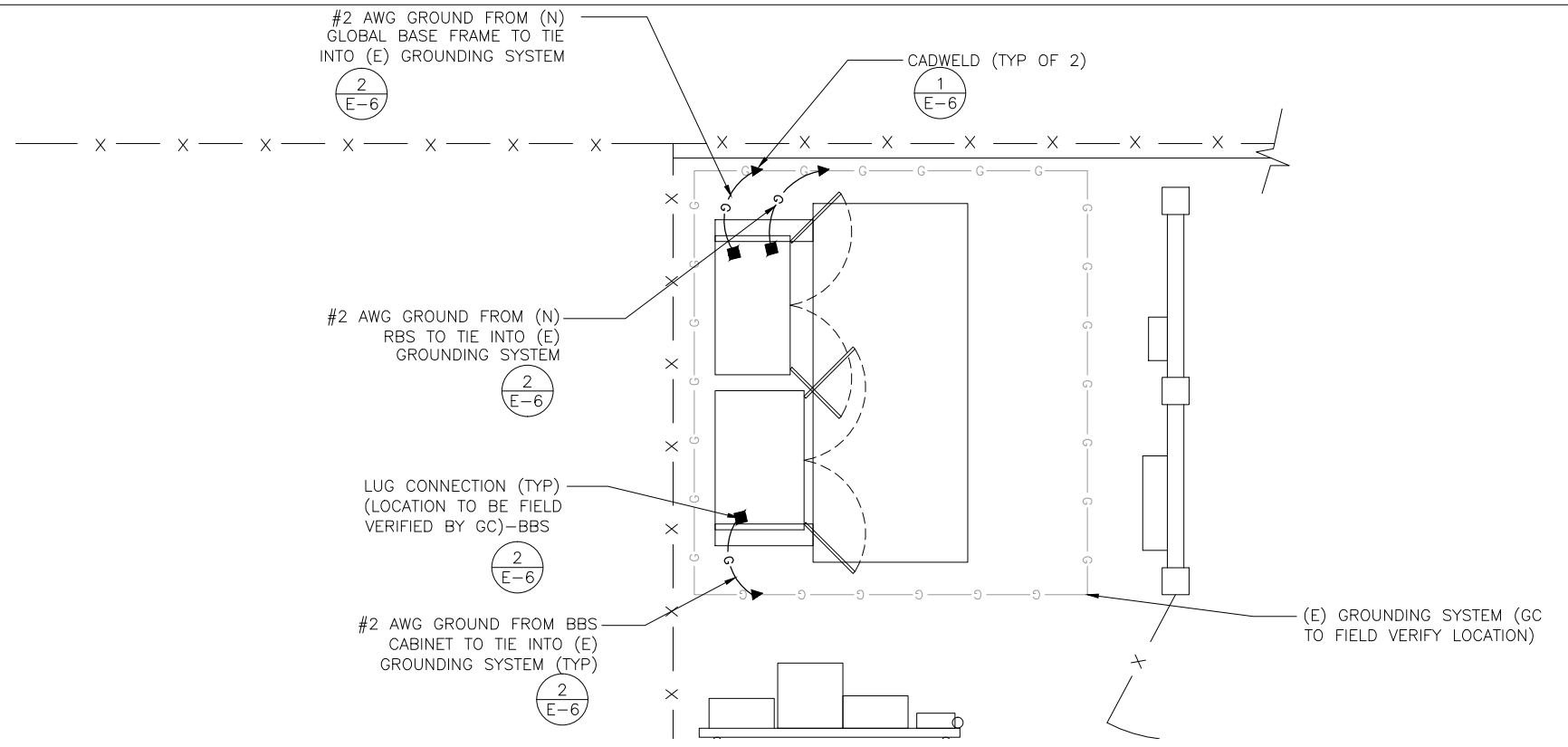

1 EQUIPMENT GROUNDING PLAN (FINAL)
 SCALE: 3/8" = 1'-0"
 TRUE NORTH

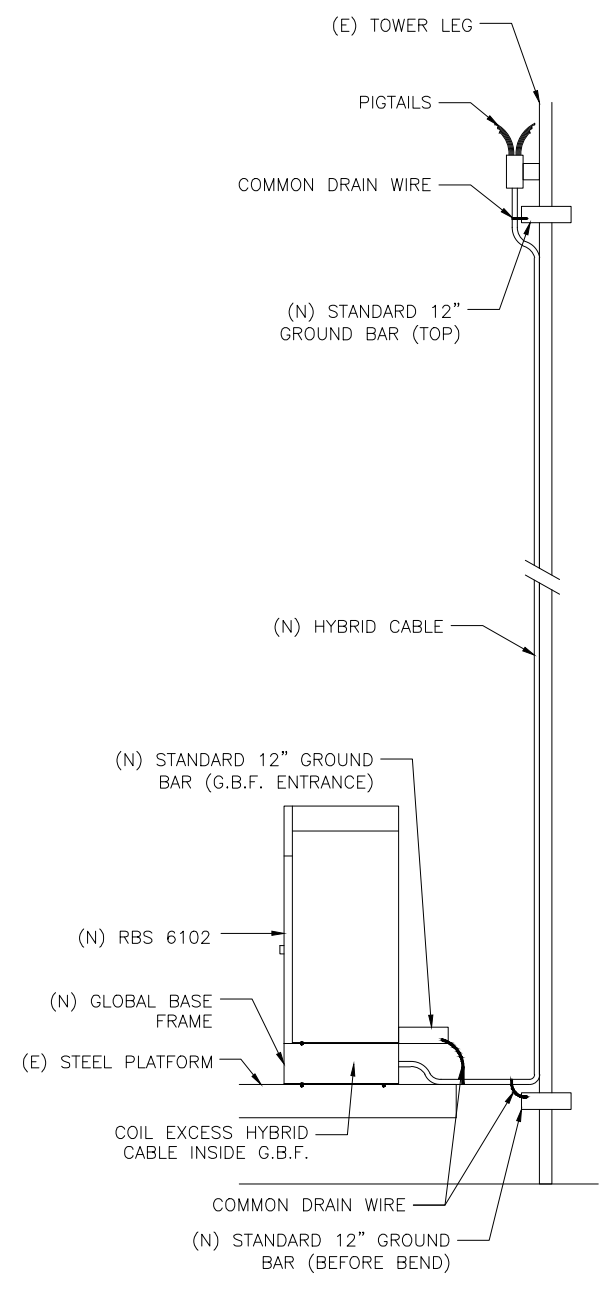

3 HYBRID GROUNDING DETAIL
 SCALE: N.T.S.

ABBREVIATIONS:

AGB	ANTENNA GROUND BAR
G	GROUND
MGB	MASTER GROUND BAR

GROUNDING LEGEND:

SYMBOL	DESCRIPTION
▶	EXOTHERMIC WELD
—G—G—G—	GROUNDWIRE
■	MECHANICAL CONNECTION

PREPARED FOR:
Sprint
 1 INTERNATIONAL BOULEVARD
 SUITE #800
 MAHWAH, N.J. 07495

CONSULTANT:

POWDER RIVER
 Development Services, LLC
 100 E. SHENANGO STREET
 SHARPSVILLE, PA 16150
 724.962.5999
 www.powderriverdev.com
 PRDS PROJ.NO. 1181-081911

SITE NAME:
SPRING LAKE FIRE STATION #43
 SITE NUMBER:
SA13XC135
 SITE ADDRESS:
 2059 W. BITTERS ROAD
 SAN ANTONIO, TX 78248

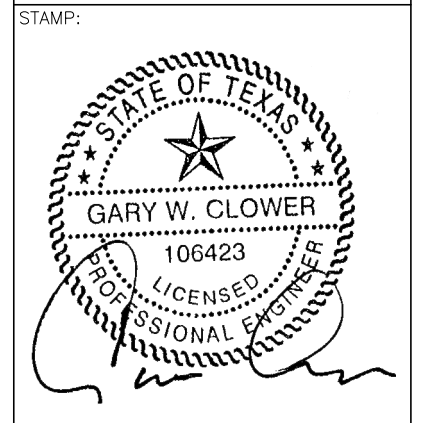

DRAWN BY:	KE		
APPROVED BY:	G.W.C.		
DATE DRAWN:	09/07/11		
REVISION			
NO	DESCRIPTION	BY	DATE
△	SUBMISSION: 90% CD	KE	09/07/11
△	FINALS	TM	11/07/11
△	FINALS-REV1	TM	08/17/12

SHEET TITLE:
GROUNDING PLANS (FINAL)
 SHEET NUMBER:
E-3

6 NOT USED
SCALE: N.T.S.

5 NOT USED
SCALE: N.T.S.

4 NOT USED
SCALE: N.T.S.

3 POWER CONNECTION AT RRUS
1/2" = 1'-0"

2 NOT USED
N.T.S.

1 DC POWER CONNECTION AT RBS
N.T.S.

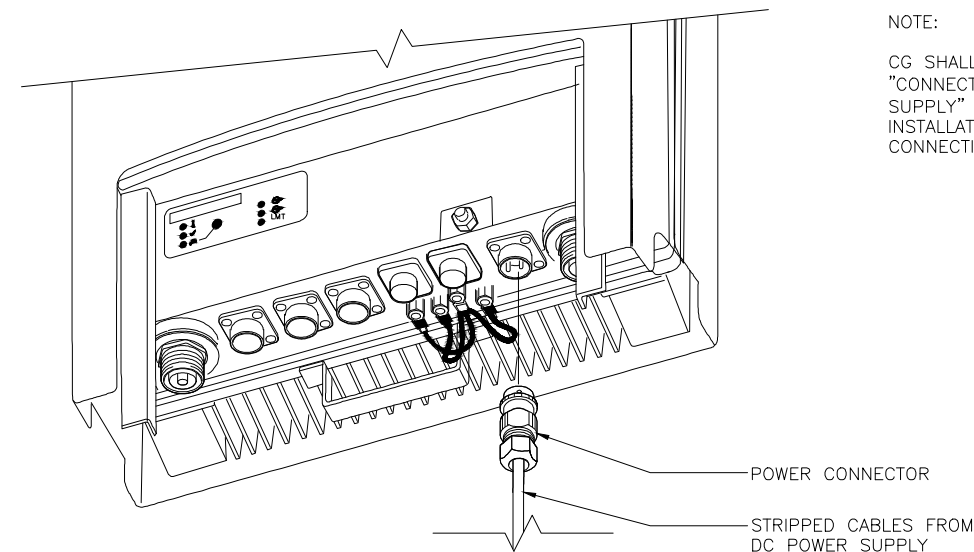

NOTE:

CG SHALL REFERENCE SECTION 8.4 "CONNECTING THE -48V DC POWER SUPPLY" OF THE ERICSSON RRUS INSTALLATION DOCUMENTS, FOR ALL CONNECTION SPECIFICATIONS.

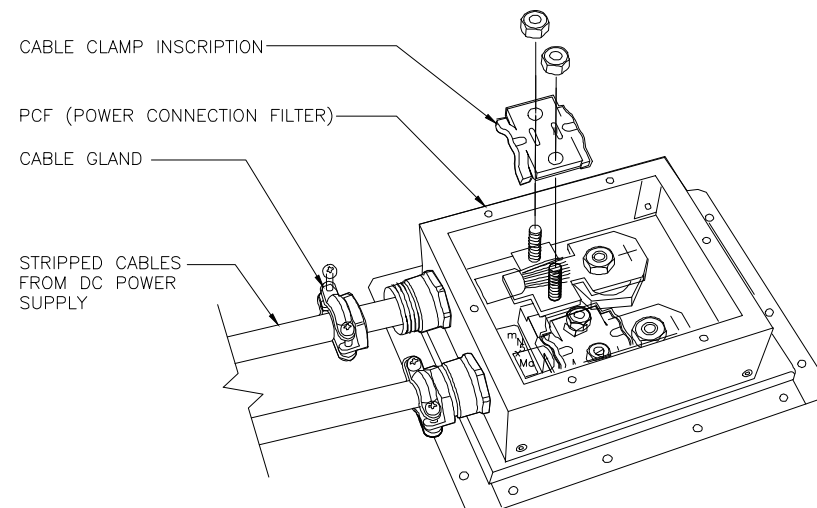

NOTE:

CG SHALL REFERENCE SECTION 10 "CONNECTING THE POWER SUPPLY" OF THE ERICSSON RBS 6102 INSTALLATION DOCUMENTS, FOR ALL CONNECTION SPECIFICATIONS.

PREPARED FOR:



1 INTERNATIONAL BOULEVARD
SUITE #800
MAHWAH, N.J. 07495

CONSULTANT:



POWDER RIVER

Development Services, LLC

100 E. SHENANGO STREET
SHARPSVILLE, PA 16150

724.962.5999

www.powderriverdev.com

PRDS PROJ.NO. 1181-081911

SITE NAME:
**SPRING LAKE
FIRE STATION #43**

SITE NUMBER:
SA13XC135

SITE ADDRESS:
2059 W. BITTERS ROAD
SAN ANTONIO, TX 78248

STAMP:



DRAWN BY:	KE		
APPROVED BY:	G.W.C.		
DATE DRAWN:	09/07/11		
REVISION			
NO	DESCRIPTION	BY	DATE
△	SUBMISSION: 90% CD	KE	09/07/11
△	FINALS	TM	11/07/11
△	FINALS-REV1	TM	08/17/12

SHEET TITLE:
ELECTRICAL DETAILS

SHEET NUMBER:
E-4

ERICSSON MM-BTS RBS 6102	ALARM CONTACT	SEVERITY	OWNER	COMMENTS	
BTS SCAN POINT 1	{2200} BBS 6102 OPEN DOOR	NC	MINOR	SERVICE ASSURANCE	RBS/RIGHT OVP1/A1
BTS SCAN POINT 2	{2100} BBS 6102 CLIMATE UNIT FAILURE	NC	MINOR	FIELD SERVICES	RBS/RIGHT OVP1/A2
BTS SCAN POINT 3	{2008} CDMA DBU1 FAN FAILURE	NC	MAJOR	FIELD SERVICES	RBS/RIGHT OVP1/A3
BTS SCAN POINT 4	{1000} UTILITY POWER FAILURE	NC	MAJOR	SERVICE ASSURANCE	RBS/RIGHT OVP1/A4
BTS SCAN POINT 5	{1200} GENERATOR FAILURE	NC	MAJOR	FIELD SERVICES	RBS/RIGHT OVP1/A5
BTS SCAN POINT 6	{1201} GENERATOR RUNNING	NC	MINOR	NO ACTION. DRMS ONLY.	RBS/RIGHT OVP1/A6
BTS SCAN POINT 7	{1202} GENERATOR LOW FUEL THRESHOLD	NC	MAJOR	FIELD SERVICES	RBS/RIGHT OVP1/A7
BTS SCAN POINT 8	CUSTOMER DEFINED				RBS/RIGHT OVP1/A8
BTS SCAN POINT 9	{2008} CDMA DBU2 FAN FAILURE	NC	MAJOR	FIELD SERVICES	RBS/RIGHT OVP2/A1
BTS SCAN POINT 10	{9000} TOWER TOP LIGHT FAILURE, NOTAM REQUIRED	NC	MAJOR	SERVICE ASSURANCE	RBS/RIGHT OVP2/A2
BTS SCAN POINT 11	{9100} TOWER SIDE LIGHT FAILURE, NO NOTAM	NC	MINOR	SERVICE ASSURANCE	RBS/RIGHT OVP2/A3
BTS SCAN POINT 12	USER DEFINED FROM STANDARDS COLUMN A ONLY				RBS/RIGHT OVP2/A4
BTS SCAN POINT 13	USER DEFINED FROM STANDARDS COLUMN A ONLY				RBS/RIGHT OVP2/A5
BTS SCAN POINT 14	USER DEFINED FROM STANDARDS COLUMN A ONLY				RBS/RIGHT OVP2/A6
BTS SCAN POINT 15	USER DEFINED FROM STANDARDS COLUMN A ONLY				RBS/RIGHT OVP2/A7
BTS SCAN POINT 16	USER DEFINED FROM STANDARDS COLUMN A ONLY				RBS/RIGHT OVP2/A8
BTS SCAN POINT 17	{2008} CDMA DBU3 FAN FAILURE	NC	MAJOR	FIELD SERVICES	RBS/LEFT OVP1/A1

*NC = NORMALLY CLOSED (CLOSED CONTACTS WITH NO ALARM CONDITION)

7 RBS ALARM SCHEDULE

SCALE: N.T.S.

NOTES:

- DO NOT INSTALL CABLE GROUND KIT AT A BEND AND ALWAYS DIRECT GROUND WIRE DOWN TO ANTENNA GROUND BAR.
- WEATHER PROOFING SHALL BE TWO-PART TAPE KIT. COLD SHRINK SHALL NOT BE USED.

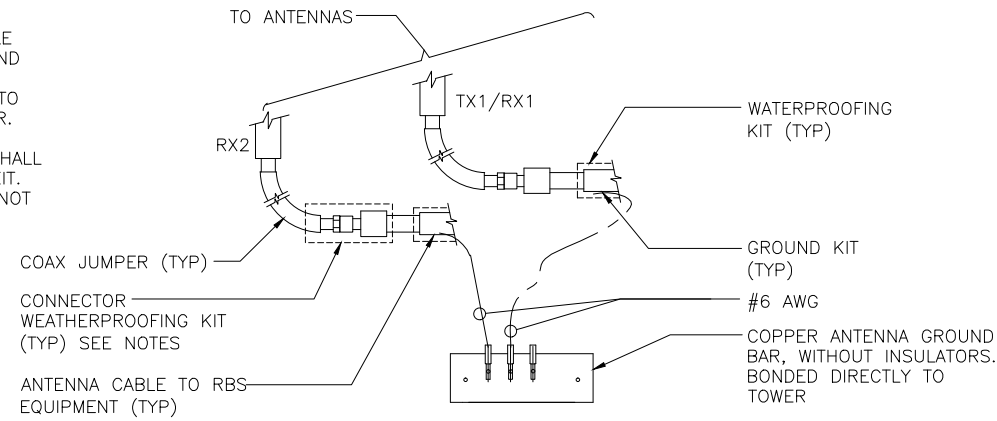

4 ANTENNA GROUNDING KIT

N.T.S.

NOTES:

- ALL HARDWARE 18-8 STAINLESS STEEL INCLUDING SPLIT WASHERS.
- COAT WIRE END WITH ANTI-OXIDATION COMPOUND PRIOR TO INSERTION INTO LUG BARREL AND CRIMPING.
- APPLY ANTI-OXIDATION COMPOUND BETWEEN ALL LUGS AND BUSS BARS PRIOR TO MATING AND BOLTING.

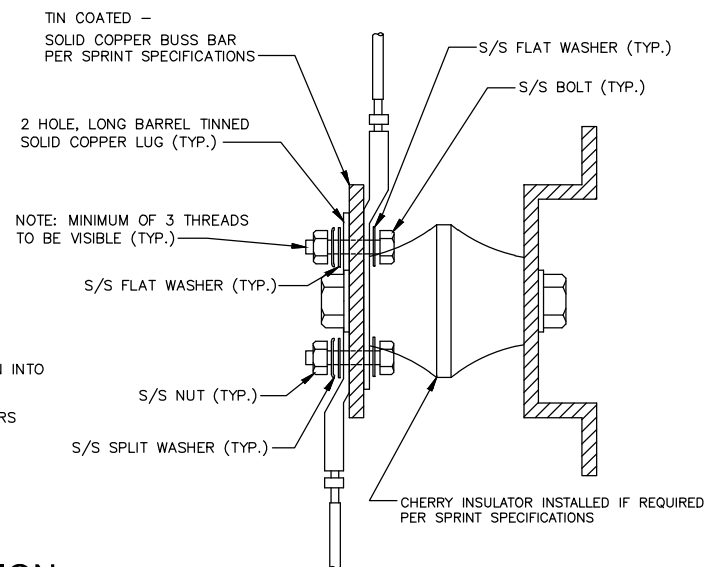

2 MECHANICAL LUG CONNECTION

SCALE: N.T.S.

6 NOT USED

SCALE: N.T.S.

5 NOT USED

SCALE: N.T.S.

3 12" GROUND BAR

N.T.S.

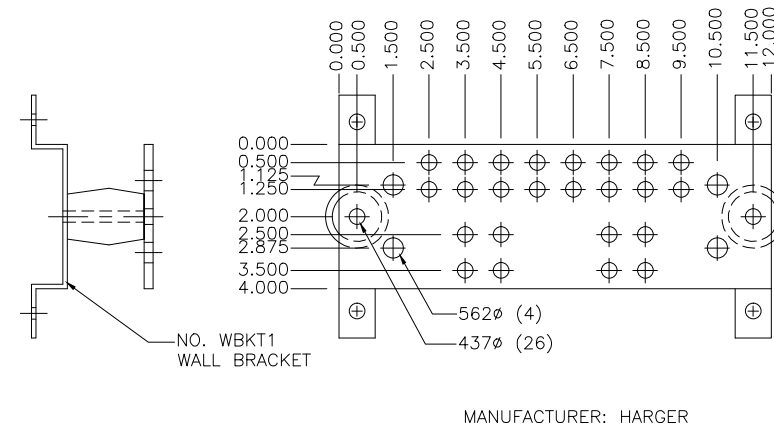

1 EXOTHERMIC WELD

N.T.S.

NOTE:

ERICO EXOTHERMIC "MOLD TYPES" SHOWN HERE ARE EXAMPLES. CONSULT WITH PROJECT MANAGER FOR SPECIFIC MOLDS TO BE USED FOR THIS PROJECT.

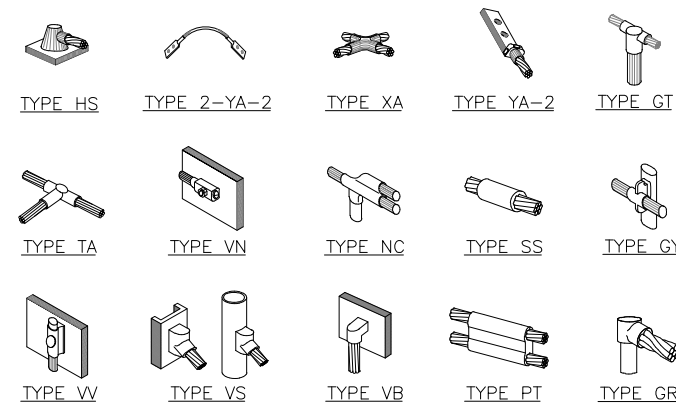

PREPARED FOR:



1 INTERNATIONAL BOULEVARD
SUITE #800
MAHWAH, N.J. 07495

CONSULTANT:



POWDER RIVER

Development Services, LLC

100 E. SHENANGO STREET
SHARPSVILLE, PA 16150

724.962.5999

www.powderriverdev.com

PRDS PROJ.NO. 1181-081911

SITE NAME:
**SPRING LAKE
FIRE STATION #43**

SITE NUMBER:
SA13XC135

SITE ADDRESS:
2059 W. BITTERS ROAD
SAN ANTONIO, TX 78248

STAMP:

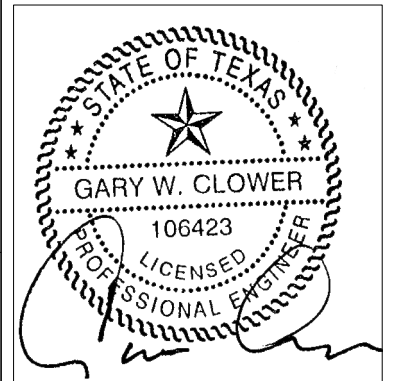

DRAWN BY: KE

APPROVED BY: G.W.C.

DATE DRAWN: 09/07/11

REVISION

NO	DESCRIPTION	BY	DATE
△	SUBMISSION: 90% CD	KE	09/07/11
△	FINALS	TM	11/07/11
△	FINALS-REV1	TM	08/17/12

SHEET TITLE:

GROUNDING DETAILS

SHEET NUMBER:

E-5

6 NOT USED
SCALE: N.T.S.

5 NOT USED
SCALE: N.T.S.

4 BBS GROUNDING
SCALE: N.T.S.

3 GBF GROUNDING DETAIL
N.T.S.

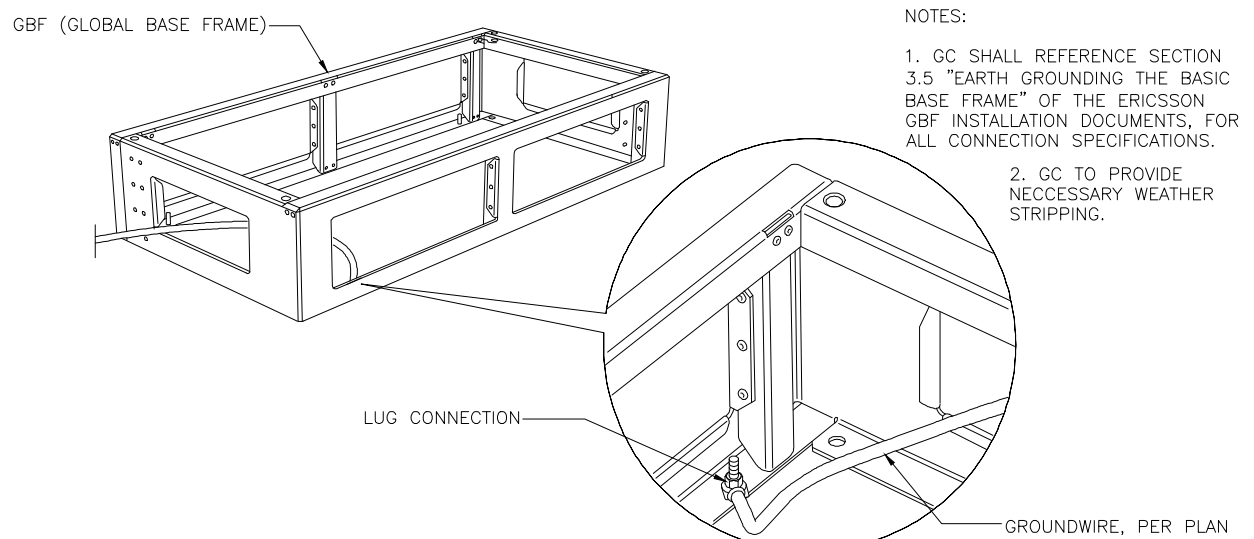
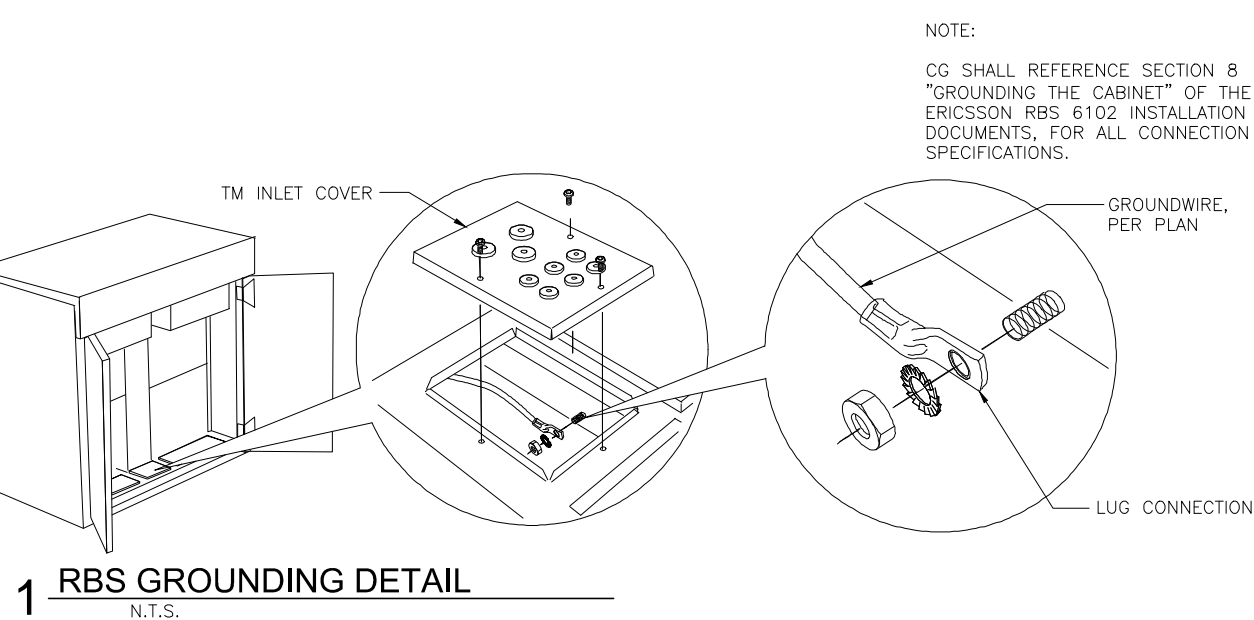
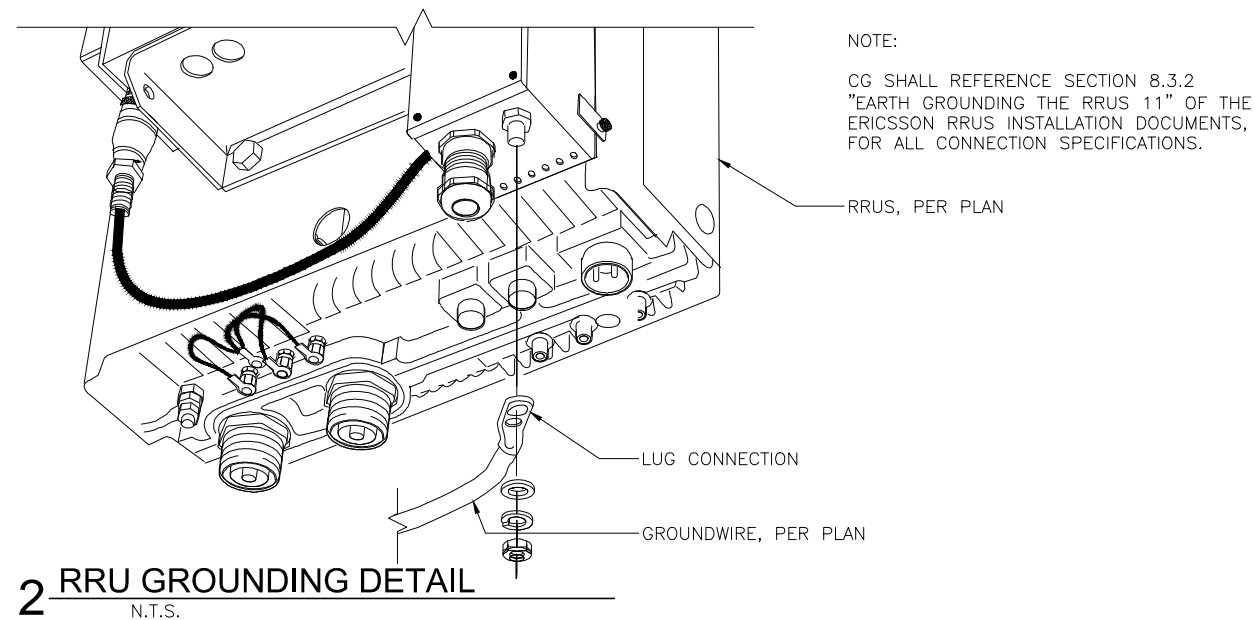

PREPARED FOR:



1 INTERNATIONAL BOULEVARD
SUITE #800
MAHWAH, N.J. 07495

CONSULTANT:



POWDER RIVER
Development Services, LLC
100 E. SHENANGO STREET
SHARPSVILLE, PA 16150
724.962.5999
www.powderriverdev.com
PRDS PROJ.NO. 1181-081911

SITE NAME:
**SPRING LAKE
FIRE STATION #43**

SITE NUMBER:
SA13XC135

SITE ADDRESS:
2059 W. BITTERS ROAD
SAN ANTONIO, TX 78248

STAMP:



DRAWN BY:	KE		
APPROVED BY:	G.W.C.		
DATE DRAWN:	09/07/11		
REVISION			
NO	DESCRIPTION	BY	DATE
△	SUBMISSION: 90% CD	KE	09/07/11
△	FINALS	TM	11/07/11
△	FINALS-REV1	TM	08/17/12

SHEET TITLE:
GROUNDING DETAILS

SHEET NUMBER:
E-6