

HISTORIC AND DESIGN REVIEW COMMISSION

July 15, 2020

HDRC CASE NO: 2020-299
ADDRESS: 120 CALLAGHAN AVE
LEGAL DESCRIPTION: NCB 719 BLK 1 LOT N 1/2 OF 5
ZONING: RM-4,H
CITY COUNCIL DIST.: 1
DISTRICT: Lavaca Historic District
APPLICANT: Mario Mendiola/MENDIOLA MARIO J
OWNER: Mario Mendiola/MENDIOLA MARIO J
TYPE OF WORK: Reconstruction in-kind of primary historic structure
APPLICATION RECEIVED: June 26, 2020
60-DAY REVIEW: Not applicable due to City Council Emergency Orders
CASE MANAGER: Stephanie Phillips

REQUEST:

The applicant is requesting a Certificate of Appropriateness for an amendment from previously approved plans for a rear addition and exterior modifications, approved at the December 19, 2019, HDRC hearing. The amendment is for the reconstruction of the primary historic structure in-kind, to include the rear addition and exterior modifications, after demolition occurred beyond the scope of approval and permits.

APPLICABLE CITATIONS:

Historic Design Guidelines, Chapter 2, Exterior Maintenance and Alterations

1. Materials: Woodwork

A. MAINTENANCE (PRESERVATION)

- i. *Inspections*—Conduct semi-annual inspections of all exterior wood elements to verify condition and determine maintenance needs.
- ii. *Cleaning*—Clean exterior surfaces annually with mild household cleaners and water. Avoid using high pressure power washing and any abrasive cleaning or stripping methods that can damage the historic wood siding and detailing.
- iii. *Paint preparation*—Remove peeling, flaking, or failing paint surfaces from historic woodwork using the gentlest means possible to protect the integrity of the historic wood surface. Acceptable methods for paint removal include scraping and sanding, thermal removal, and when necessary, mild chemical strippers. Sand blasting and water blasting should never be used to remove paint from any surface. Sand only to the next sound level of paint, not all the way to the wood, and address any moisture and deterioration issues before repainting.
- iv. *Repainting*—Paint once the surface is clean and dry using a paint type that will adhere to the surface properly. See *General Paint Type Recommendations* in Preservation Brief #10 listed under Additional Resources for more information.
- v. *Repair*—Repair deteriorated areas or refasten loose elements with an exterior wood filler, epoxy, or glue.

B. ALTERATIONS (REHABILITATION, RESTORATION, AND RECONSTRUCTION)

- i. *Façade materials*—Avoid removing materials that are in good condition or that can be repaired in place. Consider exposing original wood siding if it is currently covered with vinyl or aluminum siding, stucco, or other materials that have not achieved historic significance.
- ii. *Materials*—Use in-kind materials when possible or materials similar in size, scale, and character when exterior woodwork is beyond repair. Ensure replacement siding is installed to match the original pattern, including exposures. Do not introduce modern materials that can accelerate and hide deterioration of historic materials. Hardboard and other cementitious materials are not recommended.
- iii. *Replacement elements*—Replace wood elements in-kind as a replacement for existing wood siding, matching in profile, dimensions, material, and finish, when beyond repair.

2. Materials: Masonry and Stucco

A. MAINTENANCE (PRESERVATION)

- i. *Paint*—Avoid painting historically unpainted surfaces. Exceptions may be made for severely deteriorated material where other consolidation or stabilization methods are not appropriate. When painting is acceptable, utilize a water permeable paint to avoid trapping water within the masonry.
 - ii. *Clear area*—Keep the area where masonry or stucco meets the ground clear of water, moisture, and vegetation.
 - iii. *Vegetation*—Avoid allowing ivy or other vegetation to grow on masonry or stucco walls, as it may loosen mortar and stucco and increase trapped moisture.
 - iv. *Cleaning*—Use the gentlest means possible to clean masonry and stucco when needed, as improper cleaning can damage the surface. Avoid the use of any abrasive, strong chemical, sandblasting, or high-pressure cleaning method.
- B. ALTERATIONS (REHABILITATION, RESTORATION, AND RECONSTRUCTION)**
- i. *Patching*—Repair masonry or stucco by patching or replacing it with in-kind materials whenever possible. Utilize similar materials that are compatible with the original in terms of composition, texture, application technique, color, and detail, when in-kind replacement is not possible. EIFS is not an appropriate patching or replacement material for stucco.
 - ii. *Repointing*—The removal of old or deteriorated mortar should be done carefully by a professional to ensure that masonry units are not damaged in the process. Use mortar that matches the original in color, profile, and composition when repointing. Incompatible mortar can exceed the strength of historic masonry and results in deterioration. Ensure that the new joint matches the profile of the old joint when viewed in section. It is recommended that a test panel is prepared to ensure the mortar is the right strength and color.
 - iii. *Removing paint*—Take care when removing paint from masonry as the paint may be providing a protectant layer or hiding modifications to the building. Use the gentlest means possible, such as alkaline poultice cleaners and strippers, to remove paint from masonry.
 - iv. *Removing stucco*—Remove stucco from masonry surfaces where it is historically inappropriate. Prepare a test panel to ensure that underlying masonry has not been irreversibly damaged before proceeding.

3. Materials: Roofs

A. MAINTENANCE (PRESERVATION)

i. *Regular maintenance and cleaning*—Avoid the build-up of accumulated dirt and retained moisture. This can lead to the growth of moss and other vegetation, which can lead to roof damage. Check roof surface for breaks or holes and flashing for open seams and repair as needed.

B. ALTERATIONS (REHABILITATION, RESTORATION, AND RECONSTRUCTION)

- i. *Roof replacement*—Consider roof replacement when more than 25-30 percent of the roof area is damaged or 25-30 percent of the roof tiles (slate, clay tile, or cement) or shingles are missing or damaged.
- ii. *Roof form*—Preserve the original shape, line, pitch, and overhang of historic roofs when replacement is necessary.
- iii. *Roof features*—Preserve and repair distinctive roof features such as cornices, parapets, dormers, open eaves with exposed rafters and decorative or plain rafter tails, flared eaves or decorative purlins, and brackets with shaped ends.
- iv. *Materials: sloped roofs*—Replace roofing materials in-kind whenever possible when the roof must be replaced. Retain and re-use historic materials when large-scale replacement of roof materials other than asphalt shingles is required (e.g., slate or clay tiles). Salvaged materials should be re-used on roof forms that are most visible from the public right-of-way. Match new roofing materials to the original materials in terms of their scale, color, texture, profile, and style, or select materials consistent with the building style, when in-kind replacement is not possible.
- v. *Materials: flat roofs*—Allow use of contemporary roofing materials on flat or gently sloping roofs not visible from the public right-of-way.
- vi. *Materials: metal roofs*—Use metal roofs on structures that historically had a metal roof or where a metal roof is appropriate for the style or construction period. Refer to Checklist for Metal Roofs on page 10 for desired metal roof specifications when considering a new metal roof. New metal roofs that adhere to these guidelines can be approved administratively as long as documentation can be provided that shows that the home has historically had a metal roof.
- vii. *Roof vents*—Maintain existing historic roof vents. When deteriorated beyond repair, replace roof vents in-kind or with one similar in design and material to those historically used when in-kind replacement is not possible.

4. Materials: Metal

A. MAINTENANCE (PRESERVATION)

- i. *Cleaning*—Use the gentlest means possible when cleaning metal features to avoid damaging the historic finish. Prepare a test panel to determine appropriate cleaning methods before proceeding. Use a wire brush to remove corrosion or paint build up on hard metals like wrought iron, steel, and cast iron.
- ii. *Repair*—Repair metal features using methods appropriate to the specific type of metal.
- iii. *Paint*—Avoid painting metals that were historically exposed such as copper and bronze.

B. ALTERATIONS (REHABILITATION, RESTORATION, AND RECONSTRUCTION)

- i. *Replacement*—Replace missing or significantly damaged metal features in-kind or with a substitute compatible in size, form, material, and general appearance to the historical feature when in-kind replacement is not possible.
- ii. *Rust*—Select replacement anchors of stainless steel to limit rust and associated expansion that can cause cracking of the surrounding material such as wood or masonry. Insert anchors into the mortar joints of masonry buildings.
- iii. *New metal features*—Add metal features based on accurate evidence of the original, such as photographs. Base the design on the architectural style of the building and historic patterns if no such evidence exists.

5. Architectural Features: Lighting

A. MAINTENANCE (PRESERVATION)

- i. *Lighting*—Preserve historic light fixtures in place and maintain through regular cleaning and repair as needed.

B. ALTERATIONS (REHABILITATION, RESTORATION, AND RECONSTRUCTION)

- i. *Rewiring*—Consider rewiring historic fixtures as necessary to extend their lifespan.
- ii. *Replacement lighting*—Replace missing or severely damaged historic light fixtures in-kind or with fixtures that match the original in appearance and materials when in-kind replacement is not feasible. Fit replacement fixtures to the existing mounting location.
- iii. *New light fixtures*—Avoid damage to the historic building when installing necessary new light fixtures, ensuring they may be removed in the future with little or no damage to the building. Place new light fixtures and those not historically present in locations that do not distract from the façade of the building while still directing light where needed. New light fixtures should be unobtrusive in design and should not rust or stain the building.

6. Architectural Features: Doors, Windows, and Screens

A. MAINTENANCE (PRESERVATION)

- i. *Openings*—Preserve existing window and door openings. Avoid enlarging or diminishing to fit stock sizes or air conditioning units. Avoid filling in historic door or window openings. Avoid creating new primary entrances or window openings on the primary façade or where visible from the public right-of-way.
- ii. *Doors*—Preserve historic doors including hardware, fanlights, sidelights, pilasters, and entablatures.
- iii. *Windows*—Preserve historic windows. When glass is broken, the color and clarity of replacement glass should match the original historic glass.
- iv. *Screens and shutters*—Preserve historic window screens and shutters.
- v. *Storm windows*—Install full-view storm windows on the interior of windows for improved energy efficiency. Storm window may be installed on the exterior so long as the visual impact is minimal and original architectural details are not obscured.

B. ALTERATIONS (REHABILITATION, RESTORATION, AND RECONSTRUCTION)

- i. *Doors*—Replace doors, hardware, fanlight, sidelights, pilasters, and entablatures in-kind when possible and when deteriorated beyond repair. When in-kind replacement is not feasible, ensure features match the size, material, and profile of the historic element.
- ii. *New entrances*—Ensure that new entrances, when necessary to comply with other regulations, are compatible in size, scale, shape, proportion, material, and massing with historic entrances.
- iii. *Glazed area*—Avoid installing interior floors or suspended ceilings that block the glazed area of historic windows.
- iv. *Window design*—Install new windows to match the historic or existing windows in terms of size, type, configuration, material, form, appearance, and detail when original windows are deteriorated beyond repair.
- v. *Muntins*—Use the exterior muntin pattern, profile, and size appropriate for the historic building when replacement windows are necessary. Do not use internal muntins sandwiched between layers of glass.
- vi. *Replacement glass*—Use clear glass when replacement glass is necessary. Do not use tinted glass, reflective glass, opaque glass, and other non-traditional glass types unless it was used historically. When established by the architectural style of the building, patterned, leaded, or colored glass can be used.
- vii. *Non-historic windows*—Replace non-historic incompatible windows with windows that are typical of the architectural style of the building.
- viii. *Security bars*—Install security bars only on the interior of windows and doors.
- ix. *Screens*—Utilize wood screen window frames matching in profile, size, and design of those historically found when the existing screens are deteriorated beyond repair. Ensure that the tint of replacement screens closely matches the original screens or those used historically.

x. *Shutters*—Incorporate shutters only where they existed historically and where appropriate to the architectural style of the house. Shutters should match the height and width of the opening and be mounted to be operational or appear to be operational. Do not mount shutters directly onto any historic wall material.

7. Architectural Features: Porches, Balconies, and Porte-Cocheres

A. MAINTENANCE (PRESERVATION)

i. *Existing porches, balconies, and porte-cocheres*—Preserve porches, balconies, and porte-cocheres. Do not add new porches, balconies, or porte-cocheres where not historically present.

ii. *Balusters*—Preserve existing balusters. When replacement is necessary, replace in-kind when possible or with balusters that match the originals in terms of materials, spacing, profile, dimension, finish, and height of the railing.

iii. *Floors*—Preserve original wood or concrete porch floors. Do not cover original porch floors of wood or concrete with carpet, tile, or other materials unless they were used historically.

B. ALTERATIONS (REHABILITATION, RESTORATION, AND RECONSTRUCTION)

i. *Front porches*—Refrain from enclosing front porches. Approved screen panels should be simple in design as to not change the character of the structure or the historic fabric.

ii. *Side and rear porches*—Refrain from enclosing side and rear porches, particularly when connected to the main porch or balcony. Original architectural details should not be obscured by any screening or enclosure materials. Alterations to side and rear porches should result in a space that functions, and is visually interpreted as, a porch.

iii. *Replacement*—Replace in-kind porches, balconies, porte-cocheres, and related elements, such as ceilings, floors, and columns, when such features are deteriorated beyond repair. When in-kind replacement is not feasible, the design should be compatible in scale, massing, and detail while materials should match in color, texture, dimensions, and finish.

iv. *Adding elements*—Design replacement elements, such as stairs, to be simple so as to not distract from the historic character of the building. Do not add new elements and details that create a false historic appearance.

v. *Reconstruction*—Reconstruct porches, balconies, and porte-cocheres based on accurate evidence of the original, such as photographs. If no such evidence exists, the design should be based on the architectural style of the building and historic patterns.

8. Architectural Features: Foundations

A. MAINTENANCE (PRESERVATION)

i. *Details*—Preserve the height, proportion, exposure, form, and details of a foundation such as decorative vents, grilles, and lattice work.

ii. *Ventilation*—Ensure foundations are vented to control moisture underneath the dwelling, preventing deterioration.

iii. *Drainage*—Ensure downspouts are directed away and soil is sloped away from the foundation to avoid moisture collection near the foundation.

iv. *Repair*—Inspect foundations regularly for sufficient drainage and ventilation, keeping it clear of vegetation. Also inspect for deteriorated materials such as limestone and repair accordingly. Refer to maintenance and alteration of applicable materials, for additional guidelines.

B. ALTERATIONS (REHABILITATION, RESTORATION, AND RECONSTRUCTION)

i. *Replacement features*—Ensure that features such as decorative vents and grilles and lattice panels are replaced in-kind when deteriorated beyond repair. When in-kind replacement is not possible, use features matching in size, material, and design. Replacement skirting should consist of durable, proven materials, and should either match the existing siding or be applied to have minimal visual impact.

ii. *Alternative materials*—Cedar piers may be replaced with concrete piers if they are deteriorated beyond repair.

iii. *Shoring*—Provide proper support of the structure while the foundation is rebuilt or repaired.

iv. *New utilities*—Avoid placing new utility and mechanical connections through the foundation along the primary façade or where visible from the public right-of-way.

FINDINGS:

- a. The primary structure at 120 Callaghan is a 1.5-story single family structure constructed circa 1915 in the Folk Victorian style. The home features a primary side-gable configuration, an asymmetrical front porch with turned columns, tall rectangular wood windows with a 2 over 2 configuration, and a primary front gable with decorative wood shingles. The structure is contributing to the Lavaca Historic District. A fire damaged the interior of the structure, along with a portion of the exterior roof and the rear façade, in March 2019. The applicant is requesting to reconstruct the structure in-kind.

- b. DEMOLITION AND SCOPE AMENDMENT – The applicant received approval from the Historic and Design Review Commission (HDRC) to construct a rear addition and perform exterior modifications on September 18, 2019. The applicant’s permit set was approved in April 2020, after OHP staff confirmed with the applicant via email that all stipulations were to met from the September 18, 2019, approval, including that the front columns will not be modified and the existing original windows on the right elevation will be retained. On May 11, 2020, staff received a public report that the primary structure was undergoing significant demolition. A stop work order was issued that day. In the following weeks, it was determined by Office of Historic Preservation and Development Services Department staff that the applicant had exceeded scope for both the Certificate of Appropriateness and permits on file. Since that time, the applicant has submitted revised documents for full reconstruction in-kind, and has signed a compliance agreement.
- c. DESIGN REVIEW COMMITTEE: PREVIOUS REQUEST – The applicant met with the Design Review Committee (DRC) on July 9, 2019. The DRC feedback included providing accurate existing and proposed elevations; treating the addition as a separate entity versus altering the existing primary structure; retaining the east-facing side gable and as much of the existing elevations as possible; and referencing the existing fenestration pattern on the historic structure to inform new windows on the addition. The applicant met again with the Design Review Committee on August 14, 2019, for a site visit to the property. The DRC again stressed the importance of fully accurate elevation drawings and suggested providing documentation that shows the addition’s impact to the view from the public right-of-way, including a line of sight study and a street elevation that showed the proposal in context with existing historic structures on the block. The DRC emphasized aligning the roofline from the front elevation and simplifying rooflines to maintain the street configuration and minimize the visual impact from the public right-of-way.
- d. RECONSTRUCTION – The applicant has proposed to reconstruct the primary structure in-kind, in addition to the previously-approved rear addition and exterior modifications. The applicant has submitted a set of as-built drawings that reflect the prior condition of the structure prior to its partial demolition. While staff generally finds this approach to be the most appropriate considering the current state of the structure, staff finds that the stipulations in the recommendation should be incorporated prior to the issuance of a new permit.

RECOMMENDATION:

Staff recommends approval based on findings a through d with the following stipulations:

- i. That all original windows are repaired and reinstalled in their current or original locations. The applicant is required to submit a window schedule that indicates where original and new windows are proposed. If original windows are missing, they must be fully reconstructed in-kind; replacement window products of any kind are not allowed. If reconstruction is required, the applicant must submit window specifications and details, including dimensions and shop drawings based on existing original windows, to staff for review and approval prior to the issuance of a Certificate of Appropriateness. The installation depth, trim profile, and sill detail of any reconstructed windows must match the original windows and documentation must be provided illustrating the depth and all relevant dimensions.
- ii. That the applicant submits all material specifications to staff for review and approval prior to the issuance of a Certificate of Appropriateness, to include woodlap siding, vertical and shake siding in the front gable, trim, foundation, and porch elements. No composite materials are to be used. The applicant is required to verify that all materials used in reconstruction match the existing materials that remain on site or were originally featured on the structure. Verification should occur via side-by-side photographs of original material and new in-kind material, or via an on-site visit with staff.
- iii. That the standing seam metal roof features panels that are 18 to 21 inches wide, seams that are 1 to 2 inches tall, a crimped ridge seam and a standard galvalume finish. Ridges are to feature a double-munch or crimped ridge configuration; no vented ridge caps or end caps are allowed. An on-site inspection must be scheduled with OHP staff prior to the start of work to verify that the roofing material matches the approved specifications. All chimney, flue, and related existing roof details must be preserved or reconstructed in full.
- iv. That the applicant complies with all setback requirements as required by Zoning and obtains a variance from the Board of Adjustment, if applicable.
- v. That the applicant submits accurate, comprehensive drawing updates to staff for review and approval if modifications are required as determined in the field, if applicable. No modifications to the HDRC-approved design or drawings should occur prior to review and approval by staff and the issuance of an updated Certificate of Appropriateness and permit set, if applicable. If substantial modifications are required, a new HDRC hearing may be required.

City of San Antonio One Stop



September 13, 2019

— User drawn lines

1:500

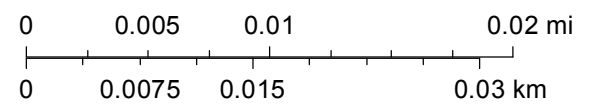

July 9, 2020 at 10:50 AM
120 Callaghan Ave
San Antonio TX 78210
United States



July 9, 2020 at 10:50 AM
118 Callaghan Ave
San Antonio TX 78210
United States



July 9, 2020 at 10:50 AM
116 Callaghan Ave
San Antonio TX 78210
United States



McCarthy
Construction
120 Callaghan Ave
San Antonio, TX 78210
714-333-3333

CITY of SAN ANTONIO
NOTICE of HEARING
HISTORIC & DESIGN
REVIEW COMMISSION

ADDRESS: 120 CALLAGHAN AVE
REQUEST: Reconstruction in-kind of primary historic structure
HEARING DATE: July 15, 2020 at 3:00 PM

ALL HDRC MEETINGS TAKE PLACE AT 1901 S. ALAMO



Investigation Report

Property

Address	120 Callaghan
District/Overlay	Lavaca
Owner Information	Mario J Mendiola

Site Visit

Date	05/11/2020
Time	02:43 PM (-5 GMT)
Context	citizen report
Present Staff	Huy Pham, Edward Hall
Present Individuals	Other
Types of Work Observed	Exterior Maintenance and Alterations, Demolition
Amount of Work Completed	75%
Description of work	Demolition of historic facades and materials beyond the scope of approval for construction of a rear addition

Action Taken

Violation Type	No Certificate of Appropriateness (Code 35-451a), Beyond scope of Certificate of Appropriateness (Code 35-451h)
OHP Action	Posted "Notice of Investigation"
Will post-work application fee apply?	Yes

Documentation



Investigation Report

Photographs





Investigation Report

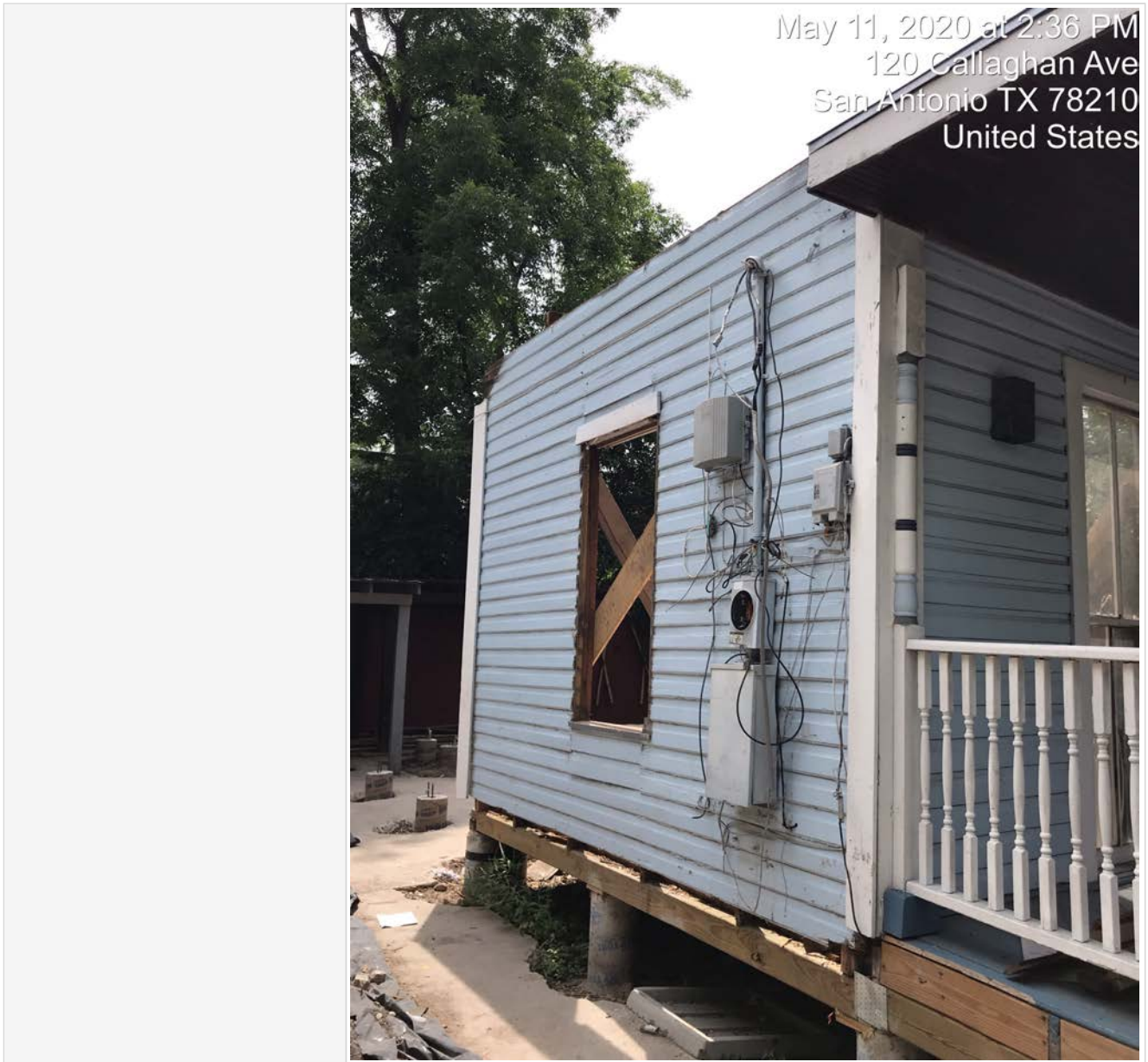



Investigation Report





Investigation Report





Investigation Report





Investigation Report





Investigation Report





Investigation Report





Investigation Report





Investigation Report

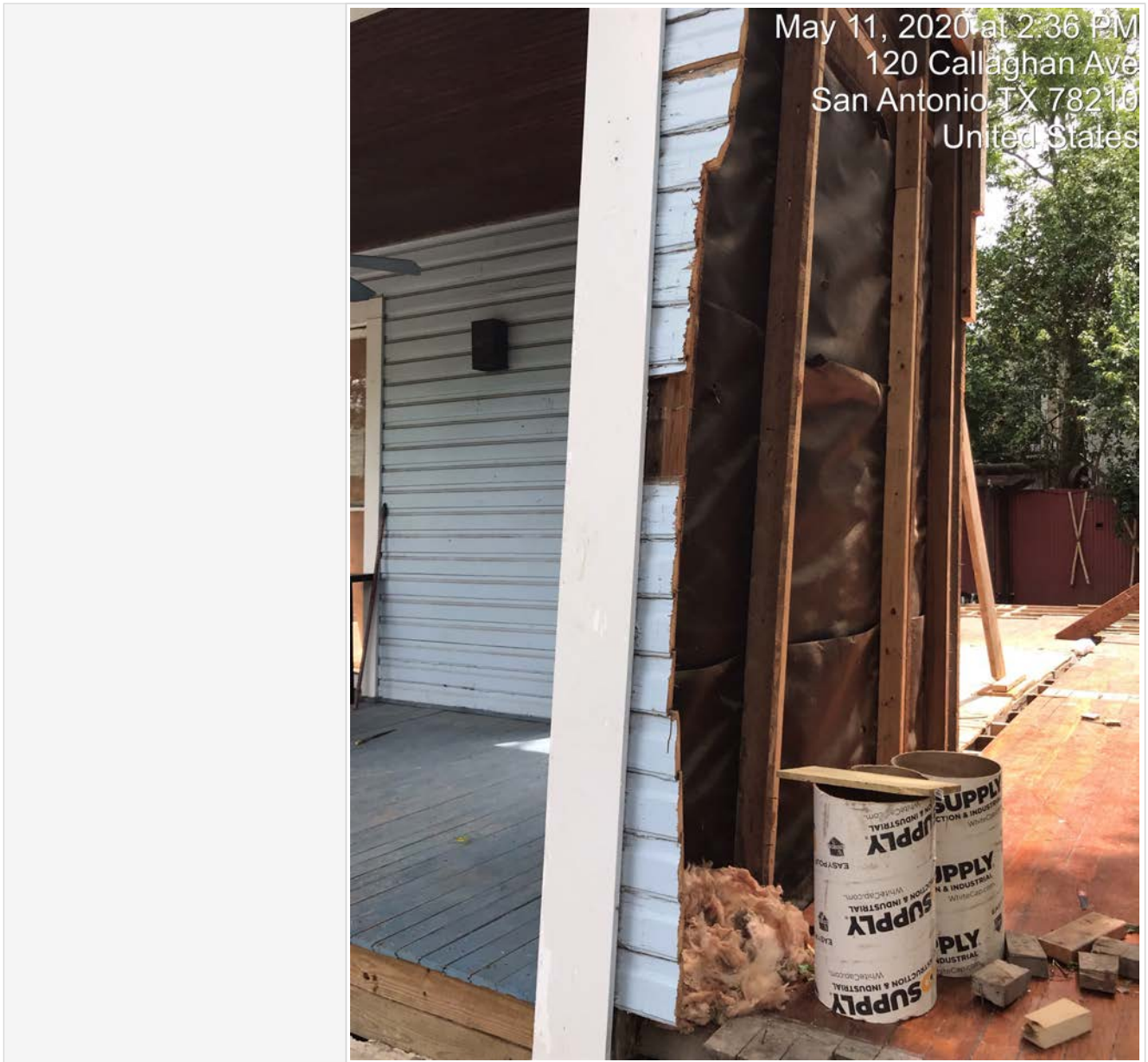



Investigation Report

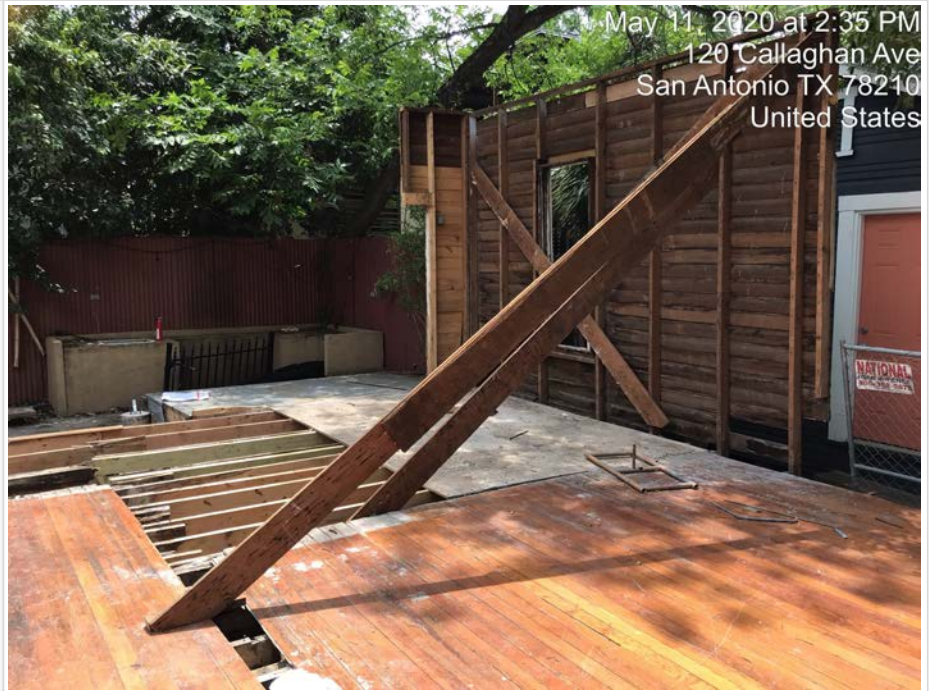



Investigation Report





Investigation Report

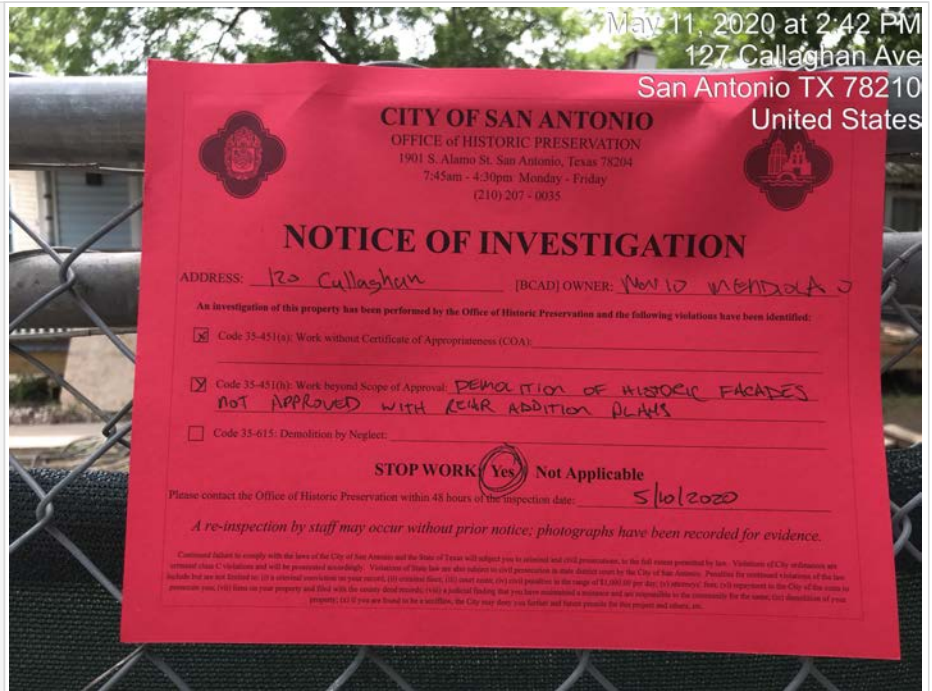



Investigation Report





Investigation Report





Investigation Report

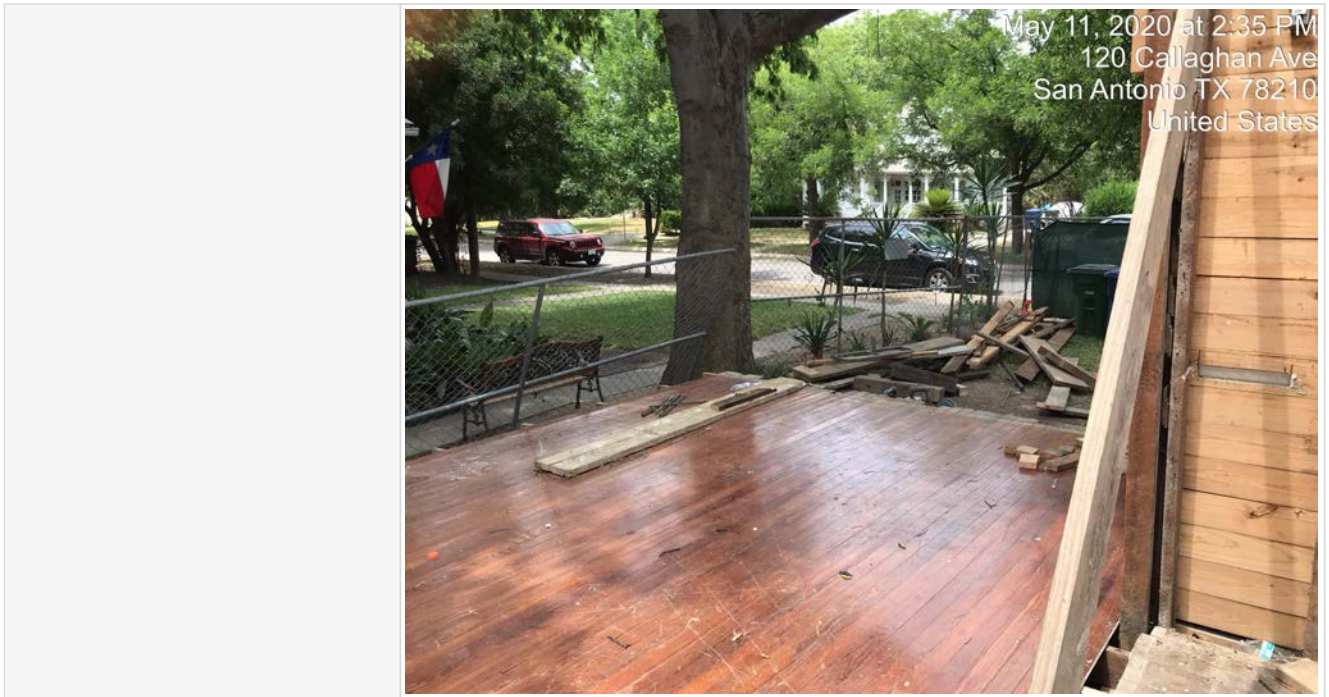



Investigation Report



05/11/2020 02:46 PM



Phone 210.400.5617
frank.telles@gmail.com

NOTES

**CUSTOM HOME PLANS FOR:
120 CALLAGHAN AVE.
SAN ANTONIO, TX**

**PLAN NO.
000
06/05/2020**

COVER SHEET & SITE PLAN

SHEET



PROPOSED PLANS FOR :

MENDIOLA RESIDENCE

120 CALLAGHAN AVE

SAN ANTONIO, TEXAS



FRANK TELLES
Builders Services

San Antonio, Texas
frank.telles@gmail.com

210.400.5617



Phone 210.400.5617
frank.telles@gmail.com

NOTES

CUSTOM HOME PLANS FOR:
120 CALLAGHAN AVE.
SAN ANTONIO, TX

INDEX OF DRAWINGS

ARCHITECTURAL
COVER COVER SHEET, GENERAL NOTES
CODE/BLDG. SUMMARY, MAPS
ADA REQUIREMENTS, AND SITE PLAN
A-100 DEMO PLAN AND ROOF PLAN
A-101 1ST AND 2ND FLOOR PLAN
A-102 NEW EXTERIOR ELEVATIONS
A-103 WALL SECTION, WINDOW & WOOD RAILING ENLARGMENT
MEP
E-101 FLOOR PLAN - LIGHTING & POWER
STRUCTURAL
S-101 FLOOR FRAMING PLANS
A-102 1ST FLOOR CEILING FRAMING PLAN
A-103 LOFT CEILING FRAMING PLAN
A-104 ROOF FRAMING PLAN
A-105 FLOOR SYSTEM DETAILS
A-106 FRAMING DETAILS



VICINITY MAP

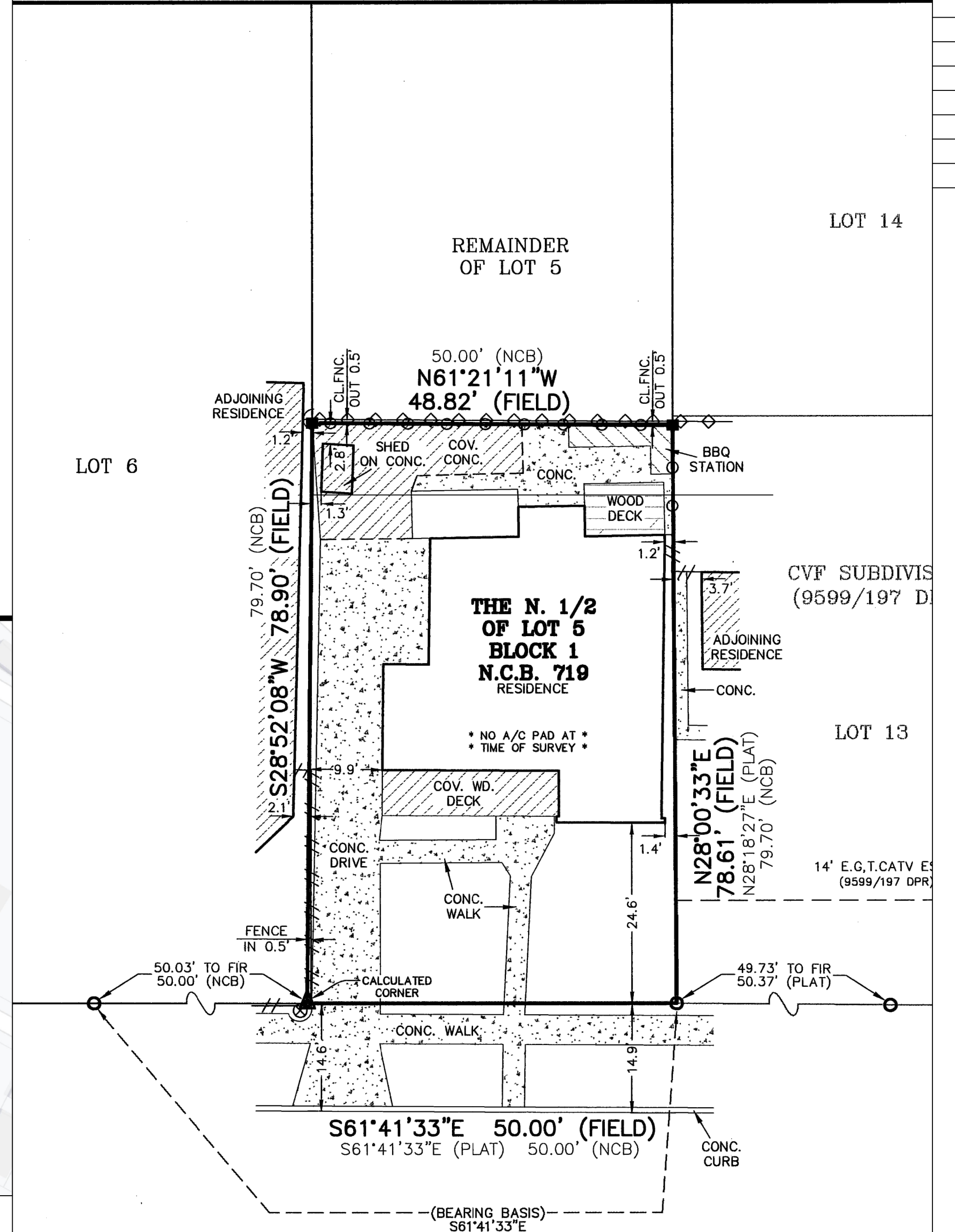

CALLAGHAN AVE.
(USPS: CALLAGHAN AVE.)
(55.6' R.O.W., ASPHALT PAVEMENT)
(RECORDED AS: CALLAGHAN AVE.)

NOTE: THE BEARINGS SHOWN HEREON ARE
BASED ON ADJOINING CVF SUBDIVISION AS
RECORDED IN VOLUME 9599, PAGE 197, DEED
AND PLAT RECORDS, BEXAR COUNTY, TEXAS.
* - AS RECORDED IN THE CITY OF SAN
ANTONIO MUNICIPAL ARCHIVES AND RECORDS.

NOTE: THIS SURVEY WAS
THE BENEFIT OF A CURRENT
CONFLICTS IN TITLE, E.A.
SETBACKS ARE NOT CER
FIELD CONDITIONS ARE

1" = 20'
GRAPHIC SCALE

MARIO J. MENDIOLA	ADDRESS: 120 CALLAGHAN AVE.	LEGEND:
PANY: ~	G.F. NO.: ~	⊗ =
TH 1/2 OF 5	BLOCK: 1	⊕ = CHAIN LINK FENCE
N: ~	N.C.B.: *719	⊖ = HOG WIRE FENCE
~	COUNTY: BEXAR	⊙ = WROUGHT IRON FENCE
~	STATE: TEXAS	⊘ =

PROJECT GENERAL NOTES

- THE OWNER WILL ASSUME RESPONSIBILITY FOR ADMINISTRATION OF THE CONTRACT FOR CONSTRUCTION AND FOR SUPERVISING THE EXECUTION OF THE CONTRACT DOCUMENTS (WORKING DRAWINGS). THE ARCHITECT IS NOT RESPONSIBLE FOR DAMAGES RESULTING FROM ERRORS AND OMISSIONS BY THOSE EXECUTING THE WORK, OR DAMAGES RESULTING FROM CHANGES IN THE WORK NOT SET FORTH IN THE CONTRACT DOCUMENTS, AND OR CHANGES NOT APPROVED IN WRITING TO THE ARCHITECT.
- CONTRACTOR SHALL HOLD ALL REQUIRED LICENCES IN THE MUNICIPALITY IN WHICH THE THE WORK IS TO BE PERFORMED. CONTRACTOR SHALL BE RESPONSIBLE FOR OBTAINING ALL PERMITS INCLUDING ANY AND ALL PERMITTING FEES.
- CONTRACTOR SHALL BE FULLY INSURED AND SUBMIT PROOF OF COVERAGE AND COVERAGE AMOUNTS WITH BID.
- CONTRACTOR SHALL CONTACT THE OWNER (OR ARCHITECT) AS SOON AS POSSIBLE WITH ANY QUESTIONS, COMMENTS OR DISCREPANCIES CONCERNING PLANS.
- CONTRACTOR SHALL FIELD VERIFY AND BE RESPONSIBLE AND UNDERSTAND ALL DIMENSIONS AND CONDITIONS AT THE JOB SITE. THE CONTRACTOR SHALL NOTIFY THE ARCHITECT OF ANY DISCREPANCIES, VARIATIONS ETC. WITH THE DIMENSIONS AND OR CONDITIONS INDICATED OR NOT INDICATED ON THESE DRAWINGS.
- EXISTING CONDITIONS, I.E. DIMENSIONS, LOCATIONS OF UTILITIES ETC. SUPPLIED BY ENGINEER. THE ARCHITECT IS NOT RESPONSIBLE FOR DISCREPANCIES, ERRORS, DAMAGES, AND CHANGES RESULTING FROM INCORRECT INFORMATION.
- BY SUBMITTING A BID, THE BIDDER AGREES AND WARRANTS THAT HE HAS VISITED THE PROJECT SITE, EXAMINED THE DRAWINGS AND SPECIFICATIONS (IF PART OF CONTRACT) AND FOUND THAT THEY ARE ADEQUATE FOR THE PROPER COMPLETION OF PROJECT.
- SHOULD CONFLICT ARISE BETWEEN GENERAL NOTES, HEREIN AND FOLLOWING, AND SPECIFICATIONS (IF PART OF CONTRACT), THE GENERAL NOTES SHALL HAVE PRECEDENCE. WRITTEN DIMENSIONS ON DRAWINGS HAVE PRECEDENCE OVER SCALED DIMENSIONS.
- DO NOT SCALE DRAWINGS FOR CONSTRUCTION PURPOSES. SEE WRITTEN DIMENSIONS. ALL DIMENSIONS ARE TO FACE OF STUD, CONCRETE, OR TO CENTER LINE, UNLESS OTHERWISE NOTED.
- CONTRACTOR TO VERIFY ALL CODES, ORDINANCES, REQUIREMENTS AND INCORPORATE INTO BIDS, PROPOSALS AND CONSTRUCTION.
- ALL NECESSARY AND REQUIRED CONTROLLED INSPECTIONS SHALL BE MADE AND FILED WITH THE APPROPRIATE DEPARTMENTS, BY AN AUTHORIZED OR QUALIFIED LICENSED BUILDING INSPECTOR.
- ALL MATERIALS AND CONSTRUCTION TO BE INCORPORATED IN THE WORK SHALL BE IN STRICT ACCORDANCE WITH THE LATEST EDITION OF THE ASTM SPECIFICATIONS APPLICABLE AND TO CONFORM TO THE STANDARDS AND RECOMMENDATIONS OF THE VARIOUS TRADE INSTITUTES (A.I.I., A.I.S.C., ETC.) WHERE APPLICABLE. ALL MATERIALS INCORPORATED INTO THE WORK SHALL BE NEW, UNLESS NOTED OTHERWISE.
- USE ONLY SKILLED AND EXPERIENCED PERSONNEL. ALL WORK SHALL BE DONE IN A WORKMAN MANNER. ALL WORK TO BE DONE IN ACCORDANCE WITH INDUSTRY STANDARD PRACTICES.
- CONTRACTOR SHALL BE RESPONSIBLE FOR ADEQUATELY BRACING AND PROTECTING ALL WORK DURING CONSTRUCTION AGAINST DAMAGE, BREAKAGE COLLAPSE, DISTORTIONS AND MISALIGNMENT ACCORDING TO APPLICABLE CODES, STANDARDS AND GOOD PRACTICES.
- EACH CONTRACTOR SHALL BE HELD STRICTLY RESPONSIBLE FOR HIS WORK.
- PROTECT ALL MATERIALS, FIXTURES AND APPLIANCES FROM WEATHER AND OR THEFT.
- CONTRACTOR SHALL KEEP SITE (INSIDE AND OUTSIDE) NEAT AND ORDERLY THROUGHOUT CONSTRUCTION. COMPLETED WORK SHALL BE CLEAN.
- PROVIDE ELECTRICAL REQUIRED FOR BURGLAR ALARM SYSTEM. CONTRACTOR TO COORDINATE INSTALLATION WITH THE SECURITY COMPANY SELECTED BY OWNER.
- ALL WALL & CEILING FINISHES TO BE CLASS B OR BETTER, FLAME SPREAD 26-75 WITH MAXIMUM SMOKE DEVELOPED OF 450.
- ALL INTERIOR TRIM TO BE CLASS C, FLAME SPREAD 76-200 WITH MAXIMUM SMOKE DEVELOPED OF 450.
- FLOOR COVERINGS TO HAVE A FLAME SPREAD RATING NOT TO EXCEED 75.
- ALL COMBUSTIBLE INTERIOR FINISH & TRIM ITEMS ARE TO BE APPLIED DIRECTLY TO A NON-COMBUSTIBLE BASE.
- PROVIDE AND INSTALL OCCUPANCY SIGN IN A CONSPICUOUS LOCATION IN ACCORDANCE WITH STATE & LOCAL CODES.
- PROVIDE AND INSTALL OCCUPANCY SIGN IN A CONSPICUOUS LOCATION IN ACCORDANCE WITH STATE & LOCAL CODES.
- SIGNAGE AS SHOWN IN THESE DRAWINGS IS SCHEMATIC ONLY FOR ILLUSTRATION PURPOSES AND DOES NOT IMPLY OR DESCRIBE ANY MEANS, METHODS, OR DETAILS PERTAINING TO INSTALLATION OF THE SIGNAGE. IT SHALL BE SOLELY THE SIGN CONTRACTOR'S RESPONSIBILITY TO DESIGN, FABRICATE, AND INSTALL THE SIGN UNDER SEPARATE PERMIT. ANY AND ALL STRUCTURAL CONSIDERATIONS SHALL BE COORDINATED BETWEEN THE SIGNAGE CONTRACTOR, OWNER, AND HIS DESIGN PROFESSIONALS. THE SIGN CONTRACTOR SHALL SUBMIT SHOP DRAWINGS DESCRIBING THE SIGNAGE DESIGN INCLUDING FINISHES, COLORS AND DESIGN DIMENSIONS TO THE OWNER FOR DESIGN INTENT REVIEW ONLY PRIOR TO SIGN FABRICATION.
- SPRINKLER WORK WHERE REQUIRED BY CODE OR CONSTRUCTION CONDITIONS SHALL BE SUBMITTED UNDER SEPARATE PERMIT BY A LICENSED SPRINKLER CONTRACTOR. THE SPRINKLER & FIRE ALARM INTO BASE BUILDING FIRE PROTECTION SYSTEM.
- NO ELEMENTS ARE TO BE ATTACHED TO OR SUPPORTED FROM THE ROOF DECK.
- G.C. SHALL NOT USE GAS POWERED CONSTRUCTION EQUIPMENT.

B2

NTS

B2

NTS

A1

1/4" = 1'-0"

A2

1/4" = 1'-0"

SITE PLAN

PLAN NO.
000
06/05/2020

COVER SHEET & SITE PLAN

SHEET

COVER



Phone 210.400.5617
frank.telles@gmail.com

NOTES

MENDIOLA'S RESIDENCE
120 CALLAGHAN AVE
SAN ANTONIO, TX

PLAN NO.
000
06/05/2020

DEMO
PLAND AND
ROOF PLAN

SHEET

A-100

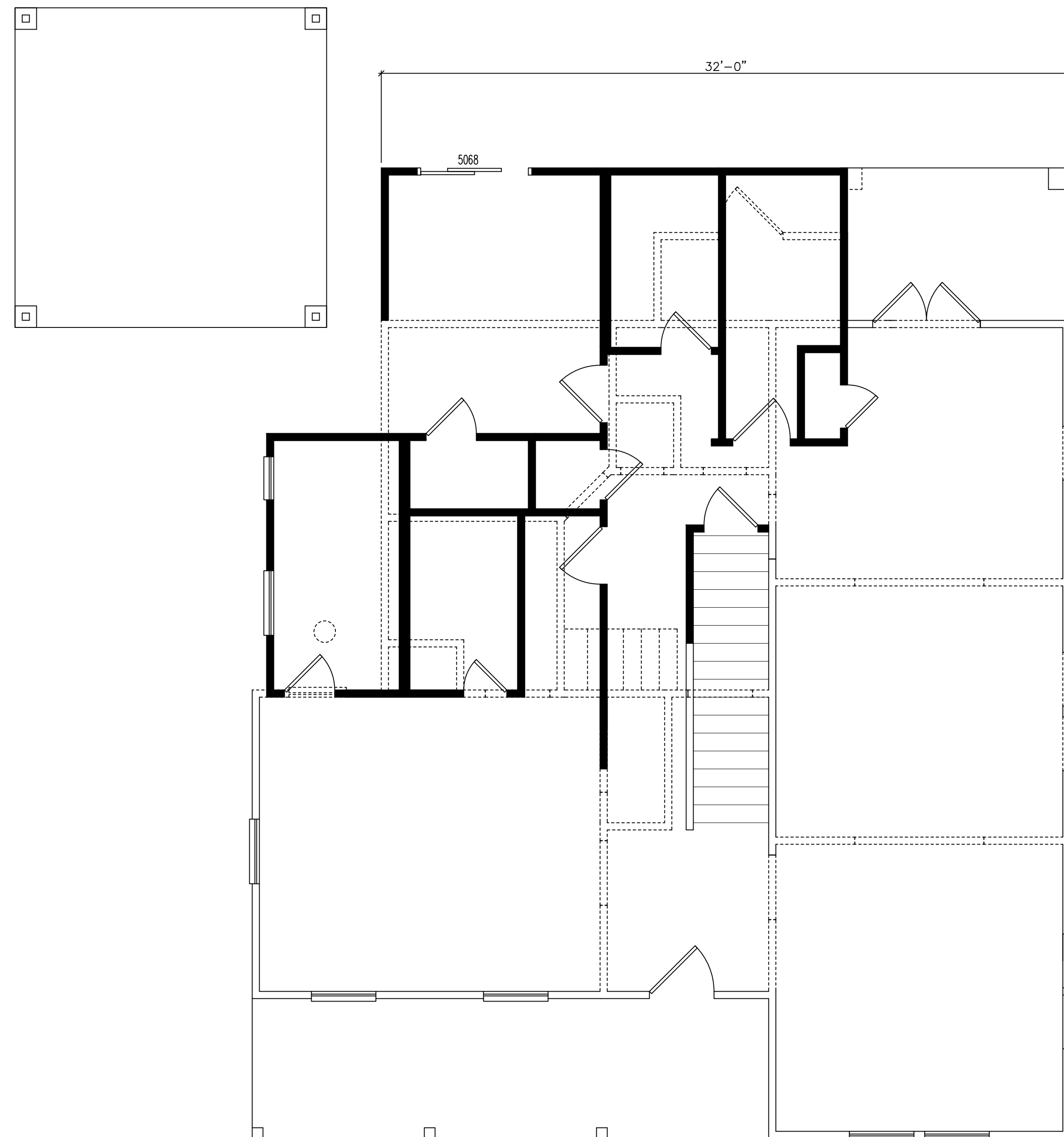

DEMO
MAIN FLOOR PLAN
11' x 17' - SCALE 1/8" = 1'-0"
24' x 36' - SCALE 1/4" = 1'-0"

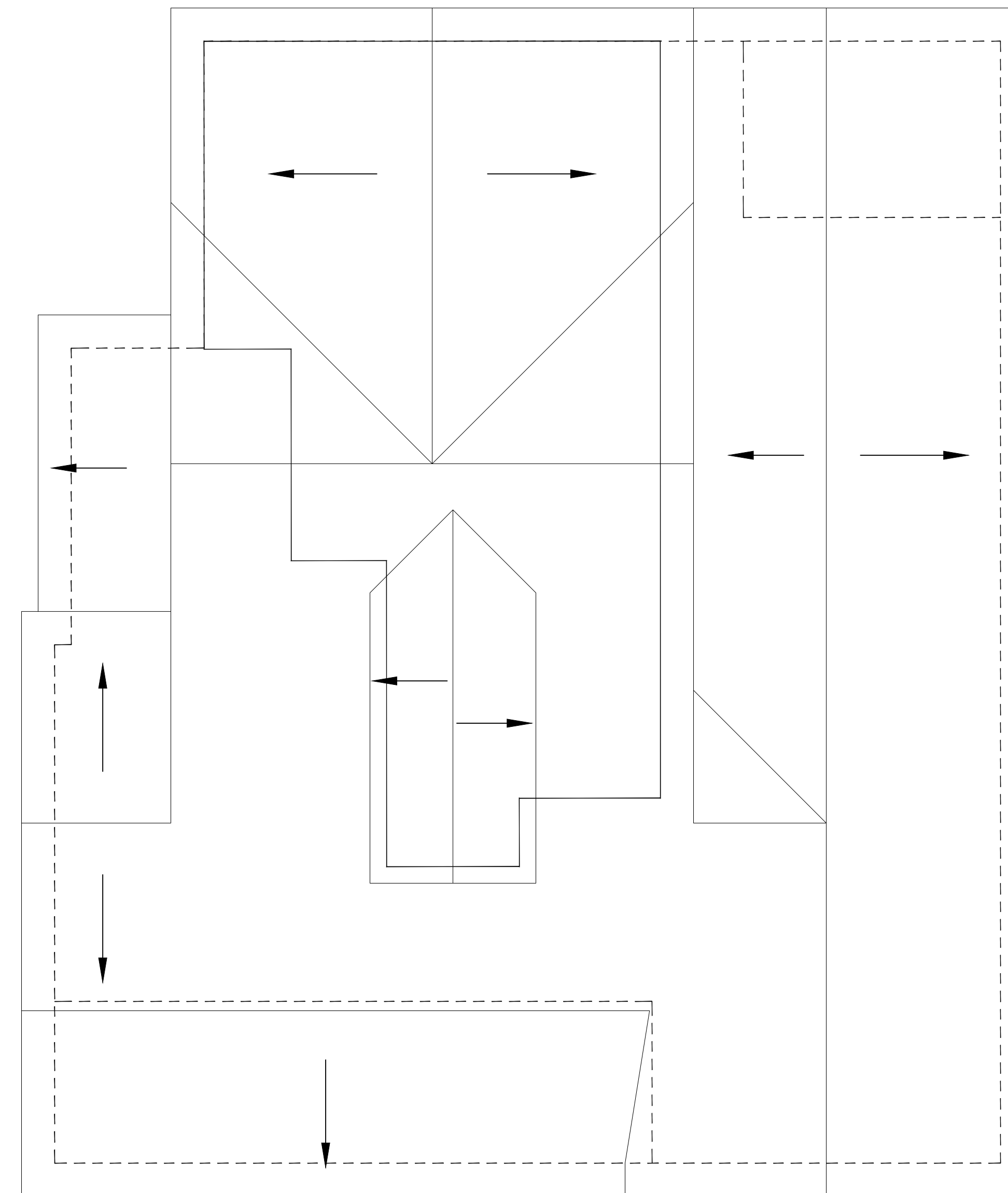

ROOF PLAN
11' x 17' - SCALE 1/8" = 1'-0"
24' x 36' - SCALE 1/4" = 1'-0"



Phone 210.400.5617
frank.telles@gmail.com

NOTES

MENDIOLA'S RESIDENCE
120 CALLAGHAN AVE
SAN ANTONIO, TX

PLAN NO.
000
06/05/2020

FLOOR
PLANS

SHEET

A-101

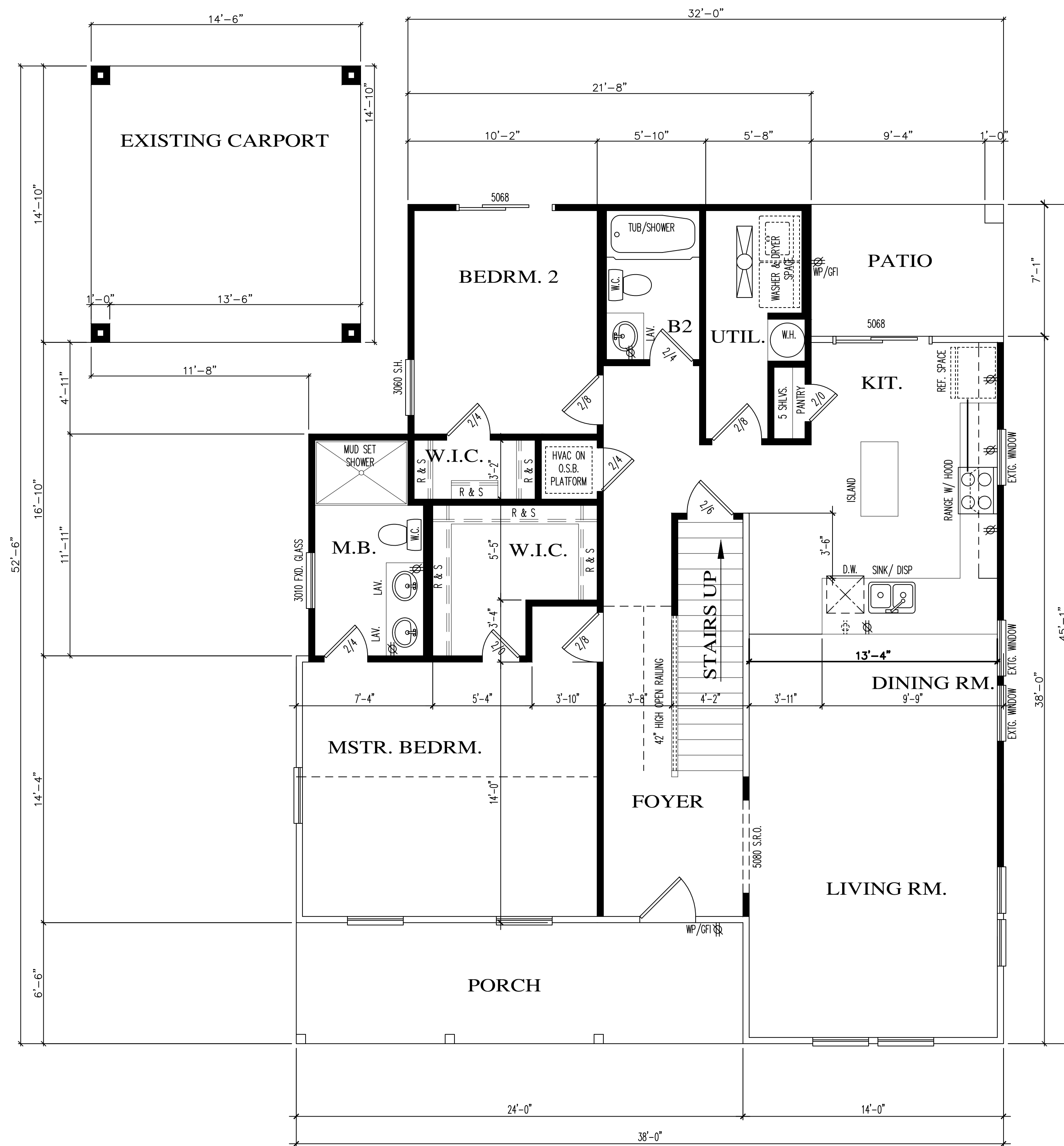

1ST LEVEL FLOOR PLAN

11' x 17' - SCALE 1/8" = 1'-0"
24' x 36' - SCALE 1/4" = 1'-0"

LEGEND

- WALLS & WINDOWS TO BE REMOVED
- WALLS & DOORS TO BE REMOVED
- WALLS & DOORS TO REMAIN
- WALLS & WINDOWS TO REMAIN
- NEW WALLS & DOORS
- NEW WALLS & WINDOWS

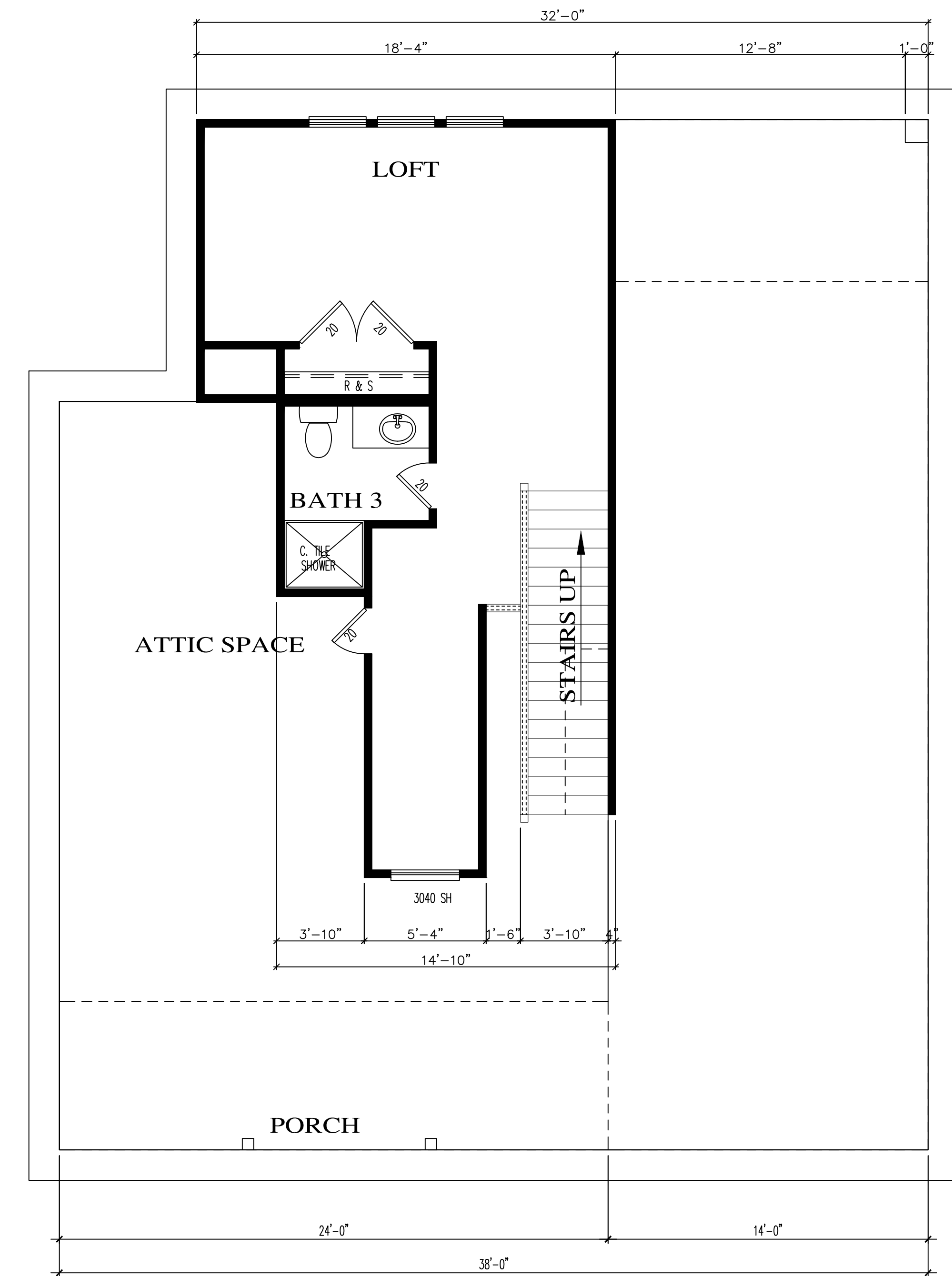

LOFT FLOOR PLAN

11' x 17' - SCALE 1/8" = 1'-0"
24' x 36' - SCALE 1/4" = 1'-0"

NOTES

MENDIOLA'S RESIDENCE
120 CALLAGHAN AVE
SAN ANTONIO, TX

PLAN NO.
000
06/05/2020

**EXTERIOR
ELEVATION**

SHEET

A-102

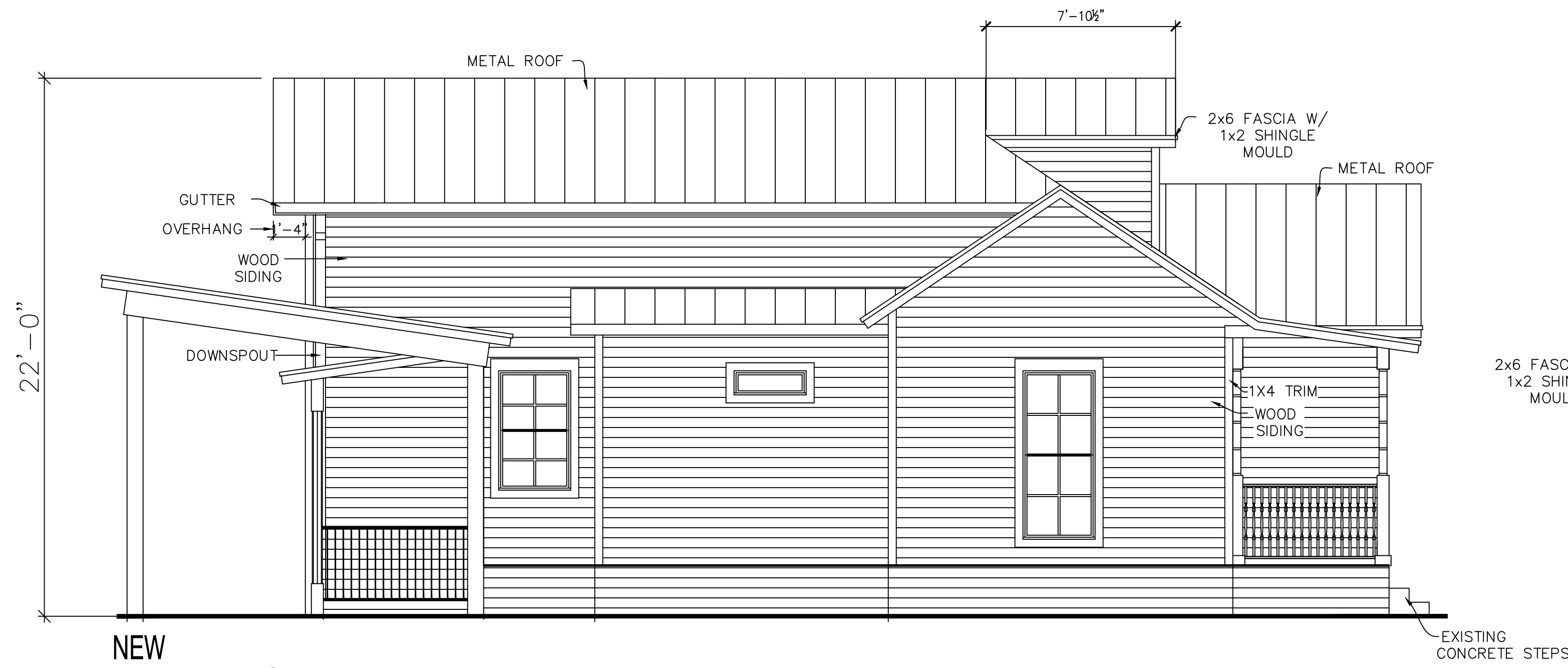

**NEW
LEFT ELEVATION**

11" x 17" - SCALE 1/8" = 1'-0"
24" x 36" - SCALE 1/4" = 1'-0"



**NEW
FRONT ELEVATION**

11" x 17" - SCALE 1/8" = 1'-0"
24" x 36" - SCALE 1/4" = 1'-0"

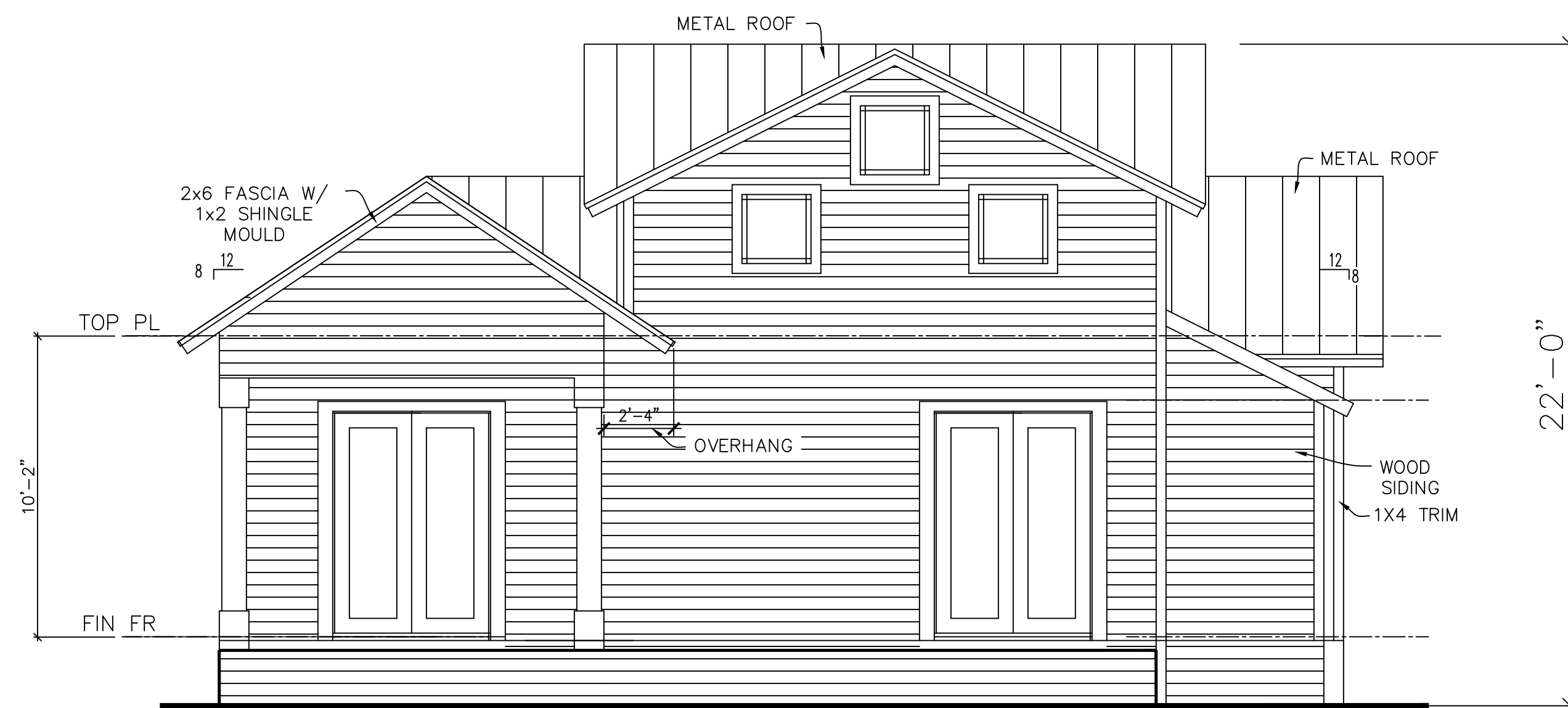

**NEW
REAR ELEVATION**

11" x 17" - SCALE 1/8" = 1'-0"
24" x 36" - SCALE 1/4" = 1'-0"

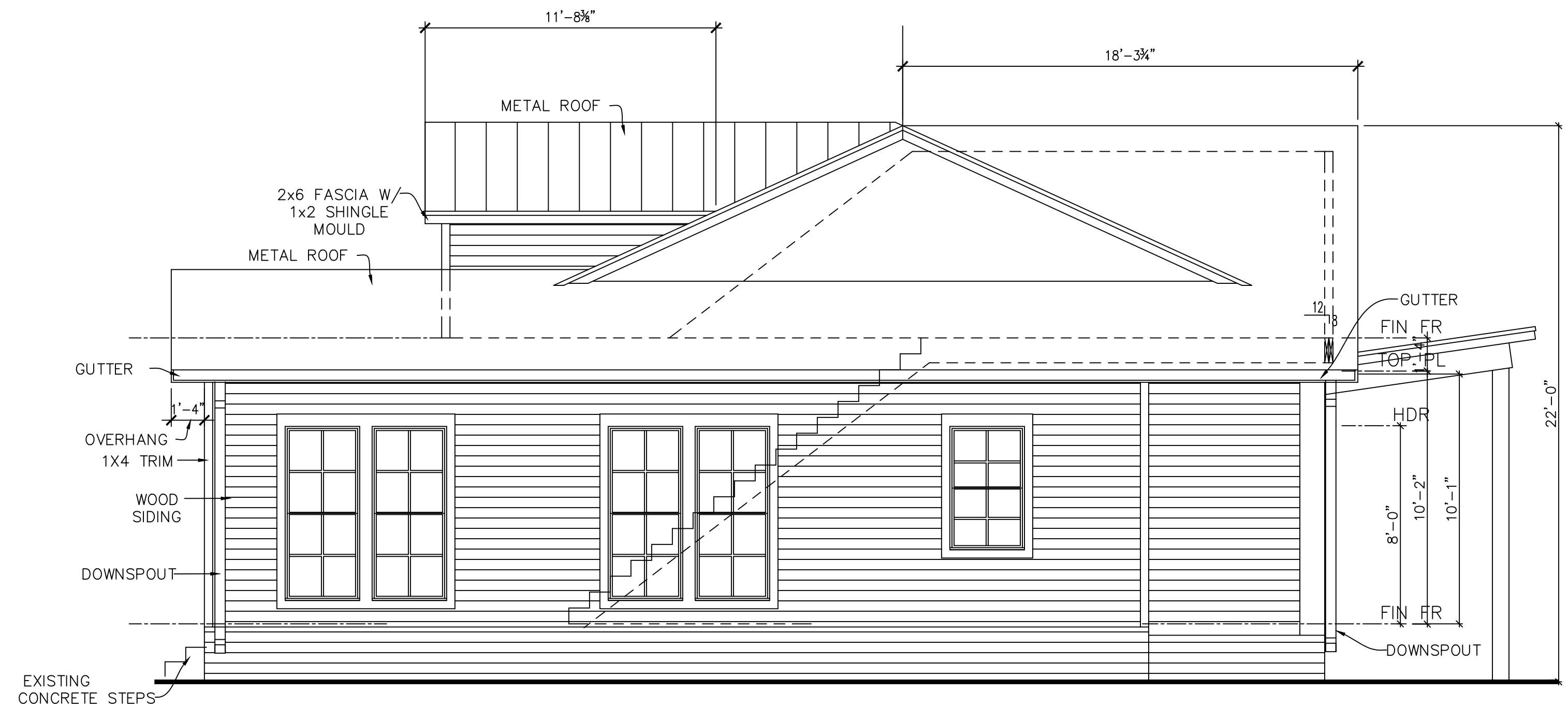

**NEW
RIGHT ELEVATION**

11" x 17" - SCALE 1/8" = 1'-0"
24" x 36" - SCALE 1/4" = 1'-0"

NOTES

MENDIOLA'S RESIDENCE
120 CALLAGHAN AVE
SAN ANTONIO, TX

PLAN NO.
000
06/05/2020

WALL SECTION
WINDOW & WOOD
RAILING
ENLARGEMENT

SHEET

A-103

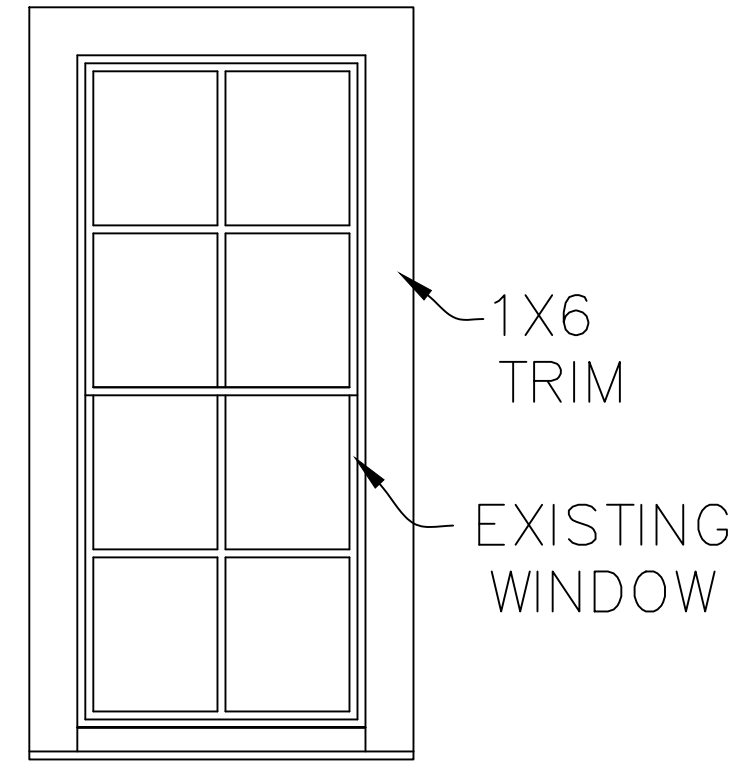

WINDOW SILL DETAIL

11" x 17" - SCALE 1/4" = 1'-0"
24" x 36" - SCALE 1/2" = 1'-0"

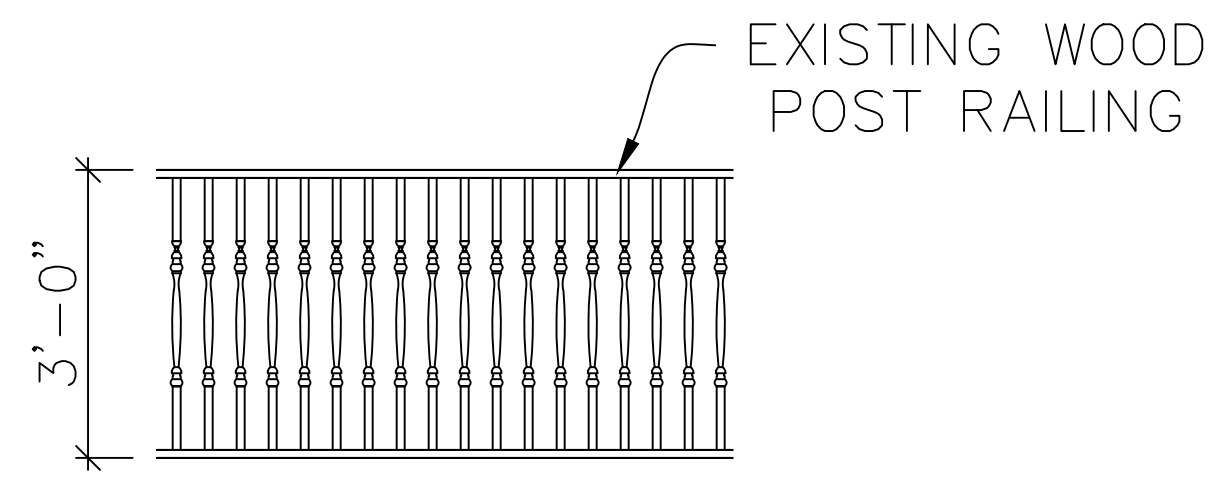

WOOD RAILING ENLARGEMENT

11" x 17" - SCALE 1/4" = 1'-0"
24" x 36" - SCALE 1/2" = 1'-0"

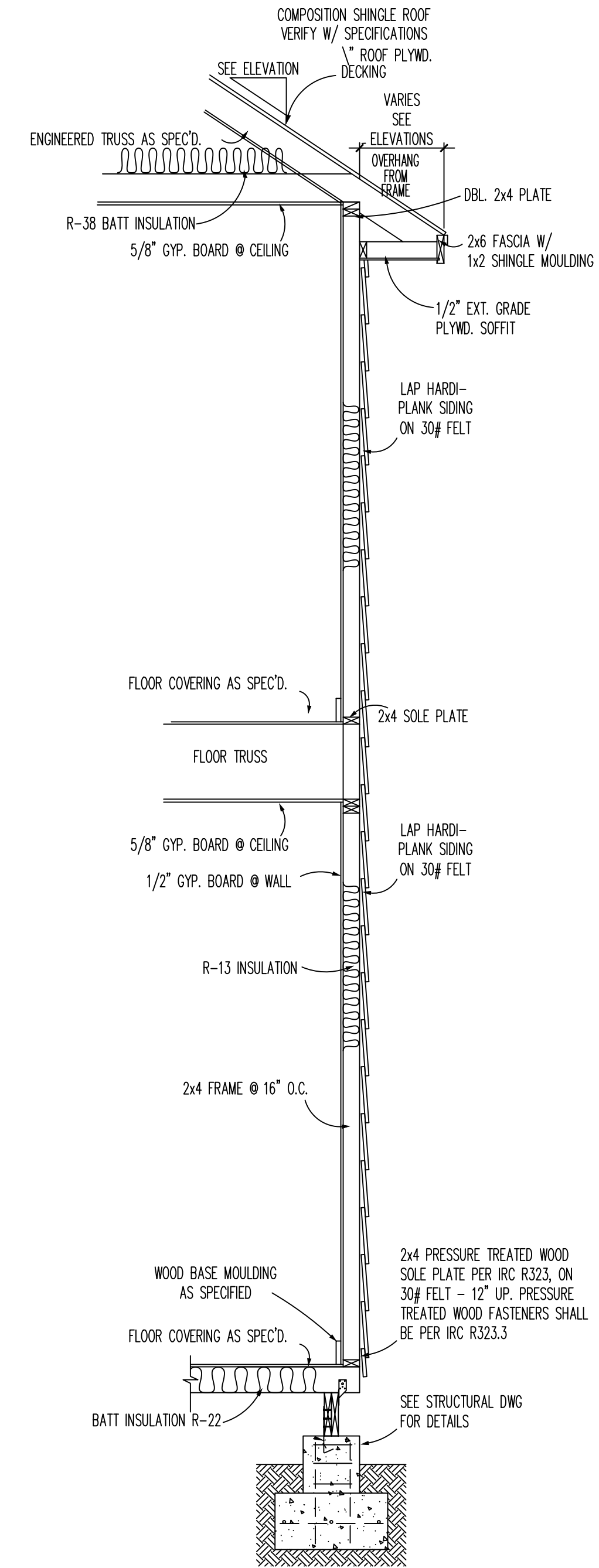

TYP. TWO-STORY SIDING WALL SECTION

SCALE: 1/4" = 1'-0" FOR 11X17 SHEET
SCALE: 1/2" = 1'-0" FOR 22X34 SHEET



Phone 210.400.5617
frank.telles@gmail.com

NOTES

MENDIOLA'S RESIDENCE
120 CALLAGHAN AVE
SAN ANTONIO, TX

PLAN NO.
000
06/05/2020

FLOOR PLAN
- LIGHTING
& POWER

SHEET

E-101

ELECTRICAL LEYND

- PENDANT LIGHT FIXTURE
- WALL MOUNTED LIGHT
- LIGHT FIXTURE
- QUAD RECEPTACLE
- FLOOR POWER PLUG
- OUTLET
- 220 OUTLET
- INSTALLED AT COUNTER HEIGHT
- DUPLEX RECEPTACLE / GROUND FAULT INTERRUPTING
- SWITCH
- 3 WAY SWITCH
- LIGHT / VENT / HEAT
- L/V/H LIGHT FIXTURE
- CURRENT LINE
- CEILING FAN
- TELEPHONE OUTLET IN WALL / 18" AFF UNLESS OTHERWISE NOTED
W = WALL PHONE / MOUNT 54" AFF
C = ABOVE COUNTERTOP
- CABLE TELEVISION / SATELLITE OUTLET
- FLOOR DATA PLUG
- FLOURESCENT LIGHT
- 2x2 FLOURESCENT LIGHT
- SMOKE DETECTOR

LEGEND

- WALLS & WINDOWS TO BE REMOVED
- WALLS & DOORS TO BE REMOVED
- WALLS & DOORS TO REMAIN
- WALLS & WINDOWS TO REMAIN
- NEW WALLS & DOORS
- NEW WALLS & WINDOWS

EXISTING CARPORT

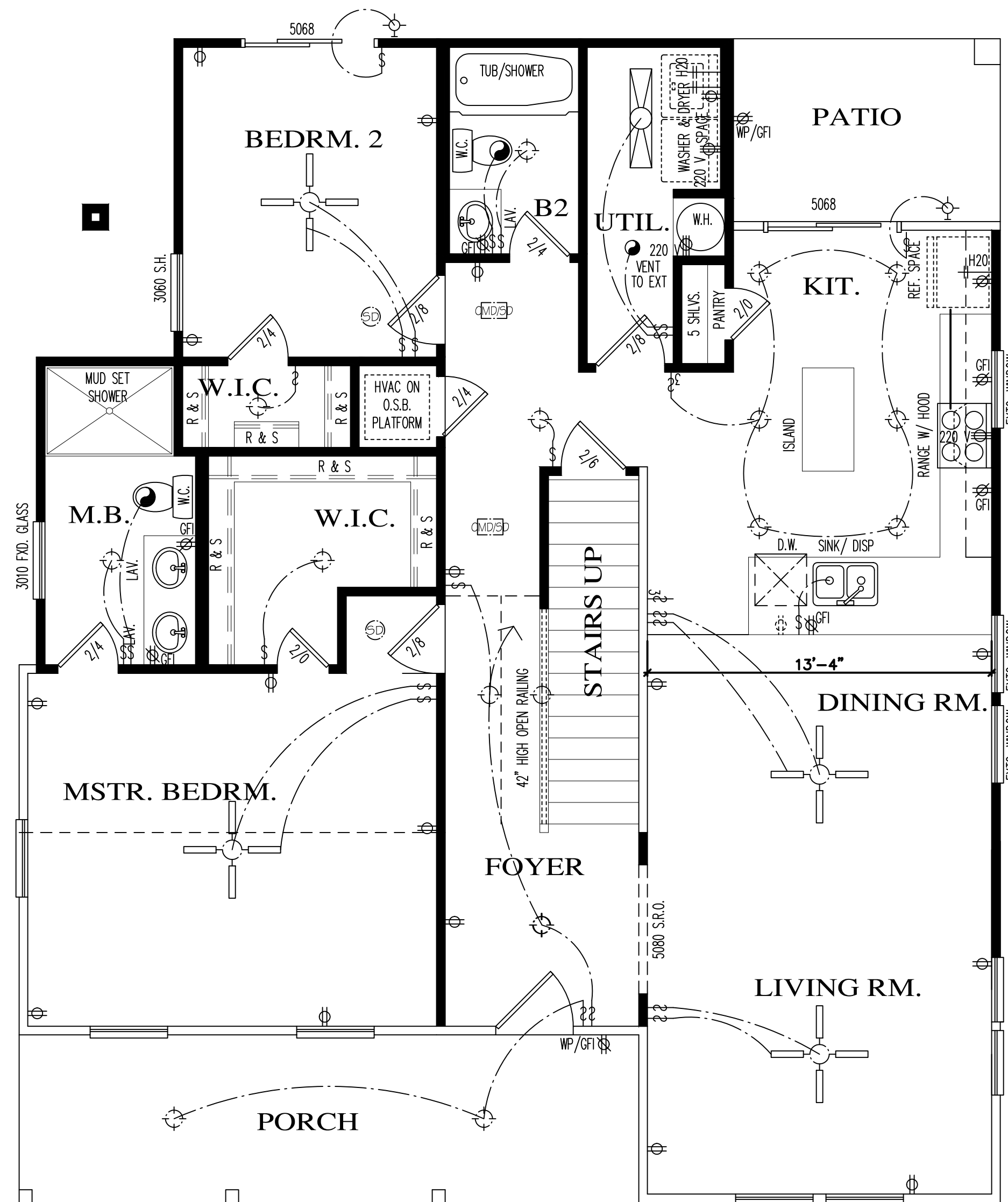

1ST LEVEL FLOOR PLAN

11" x 17" - SCALE 1/8" = 1'-0"
24" x 36" - SCALE 1/4" = 1'-0"

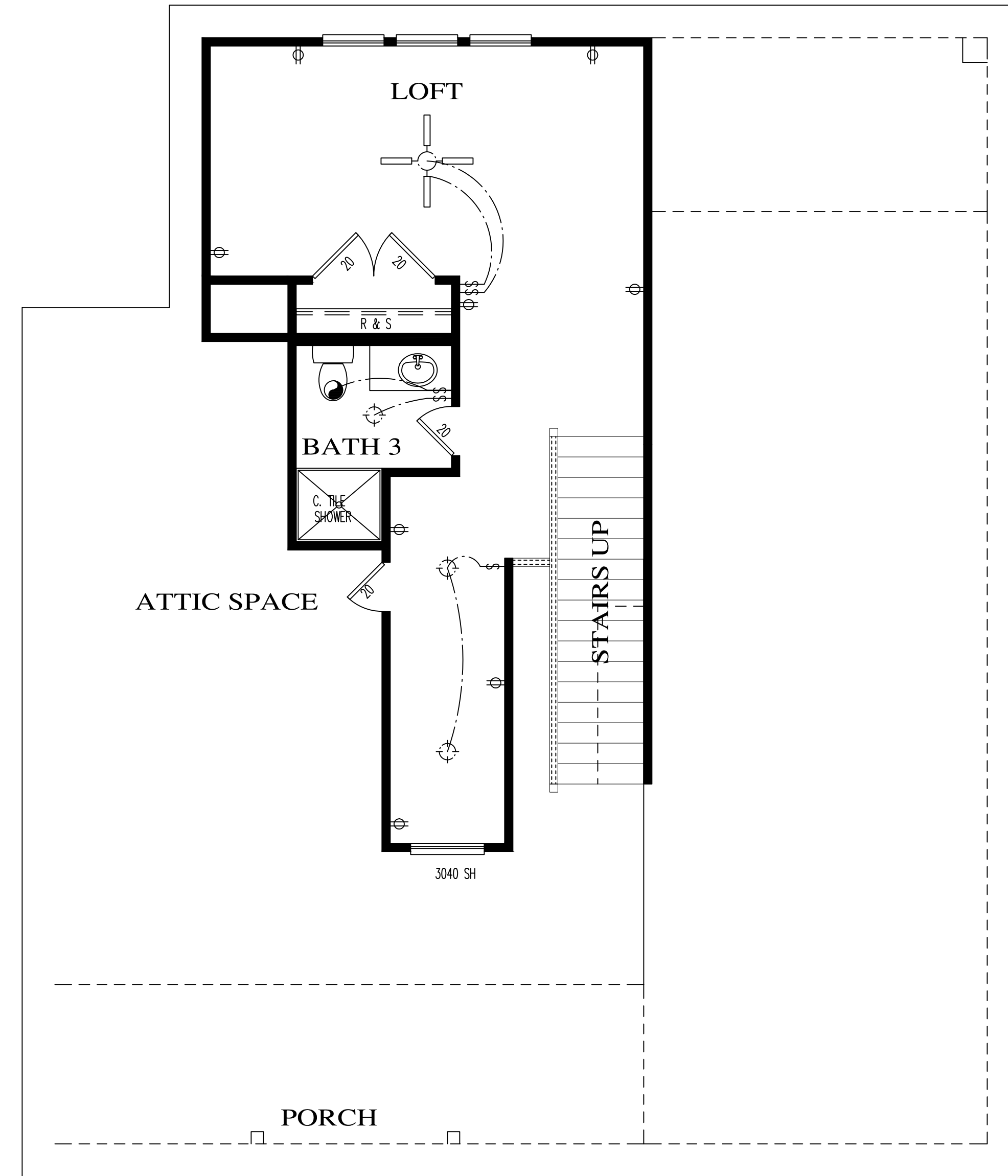

LOFT FLOOR PLAN

11" x 17" - SCALE 1/8" = 1'-0"
24" x 36" - SCALE 1/4" = 1'-0"



Phone 210.400.5617
frank.telles@gmail.com

NOTES

ATLAS ENGINEERING CONSULTANTS
FIRE ENGINEERING
119990
119990
119990

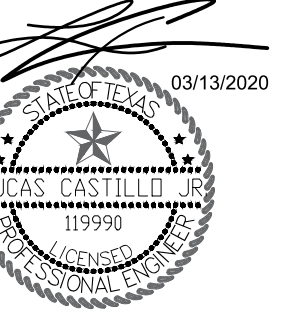

MENDIOLA'S RESIDENCE
120 CALLAGHAN AVE
SAN ANTONIO, TX

PLAN NO.
000
03/13/20

FLOOR FRAMING PLAN

SHEET

S-101

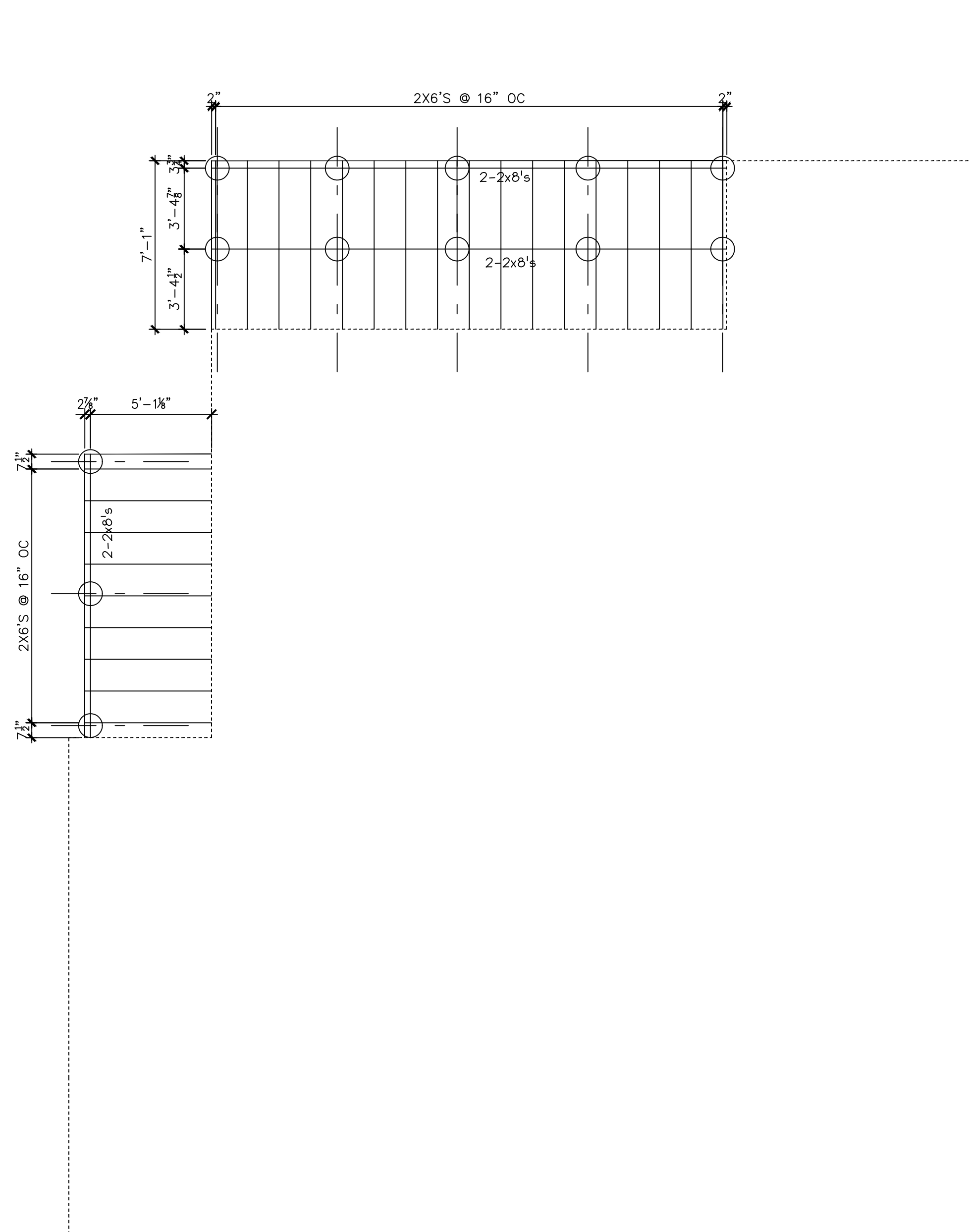

FLOOR FRAMING PLAN

11' x 17' - SCALE 1/8" = 1'-0"
24' x 36' - SCALE 1/4" = 1'-0"

NOTE:

1. VERIFY ALL DIMENSIONS WITH ARCHITECTURAL PLANS.
2. BUILDER TO ESTABLISH FINISHED FLOOR ELEVATION.
3. THIS IS A CONCRETE PIER AND WOOD BEAM FOUNDATION. ALL PIERS ARE 12" DIAMETER BEARING ON A CONCRETE PAD.
4. CONCRETE- 3000 PSI AT 28 DAYS
5. STEEL REINFORCEMENT- GRADE 60

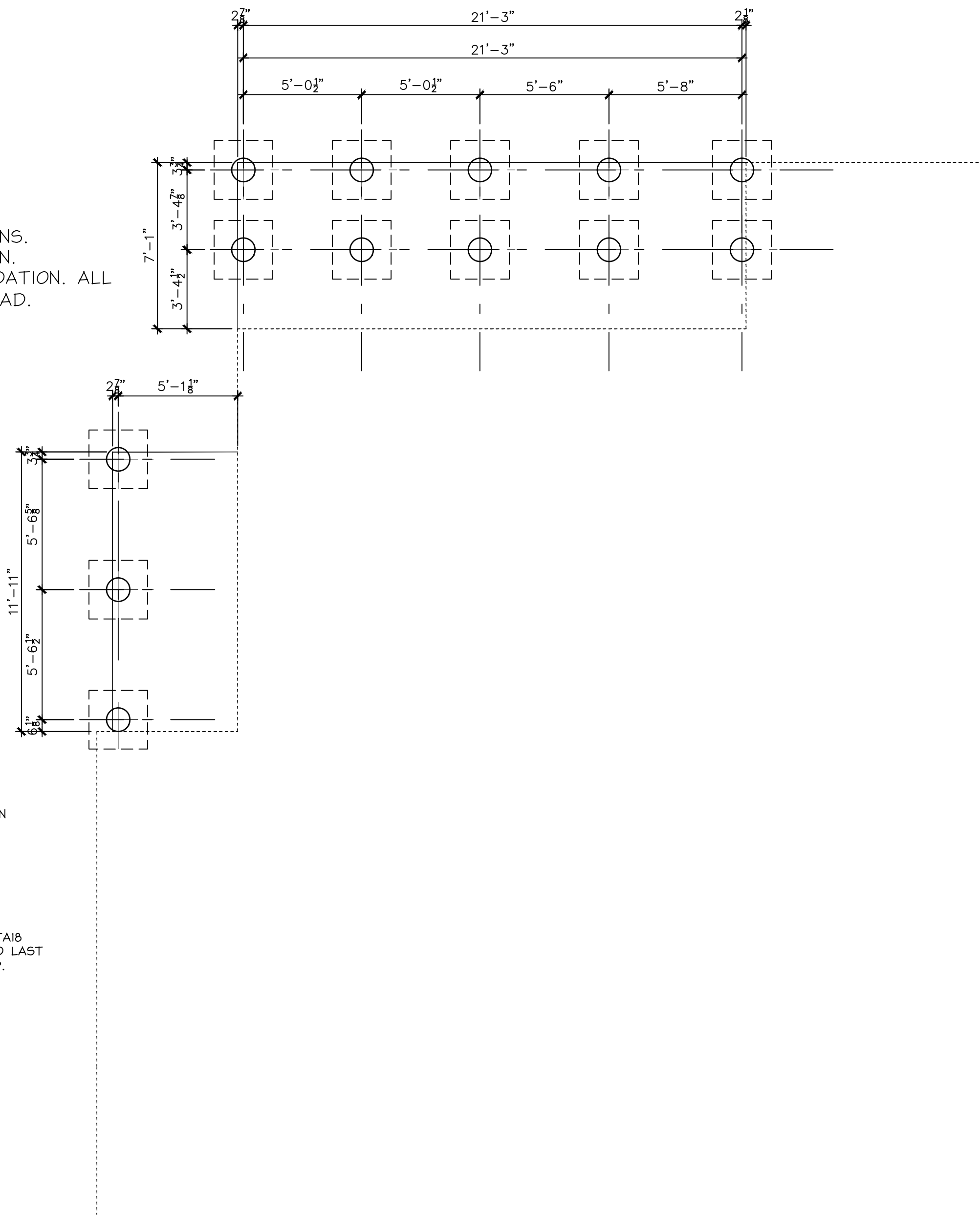
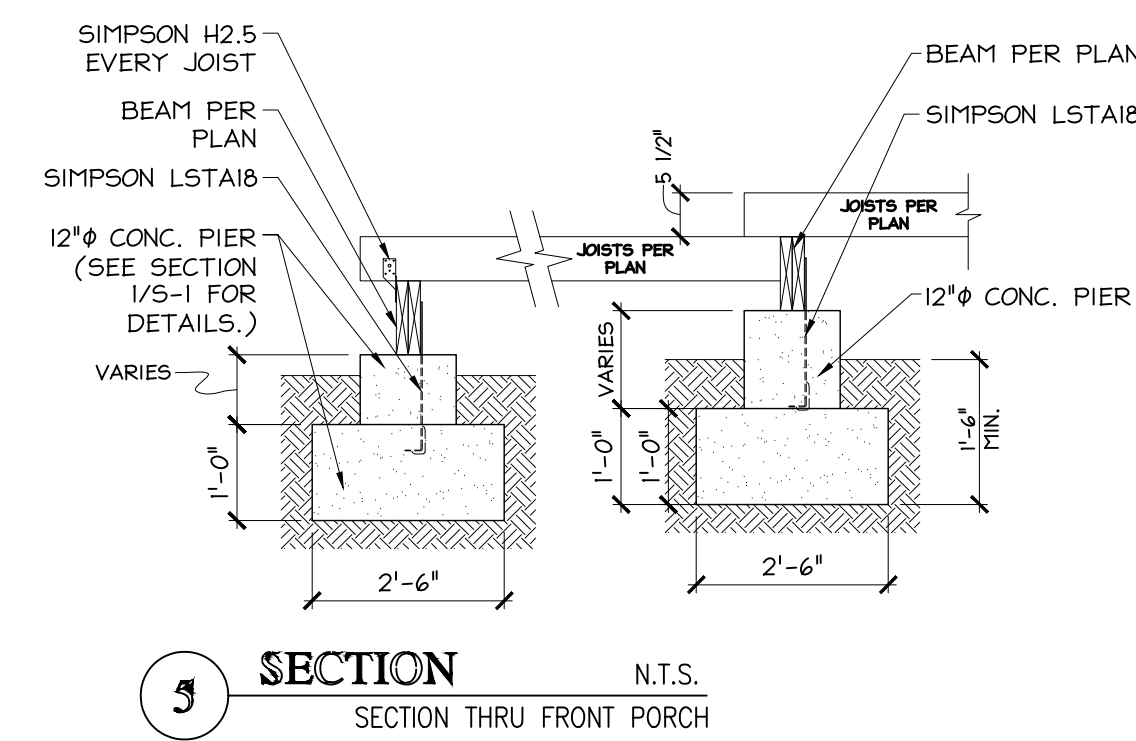
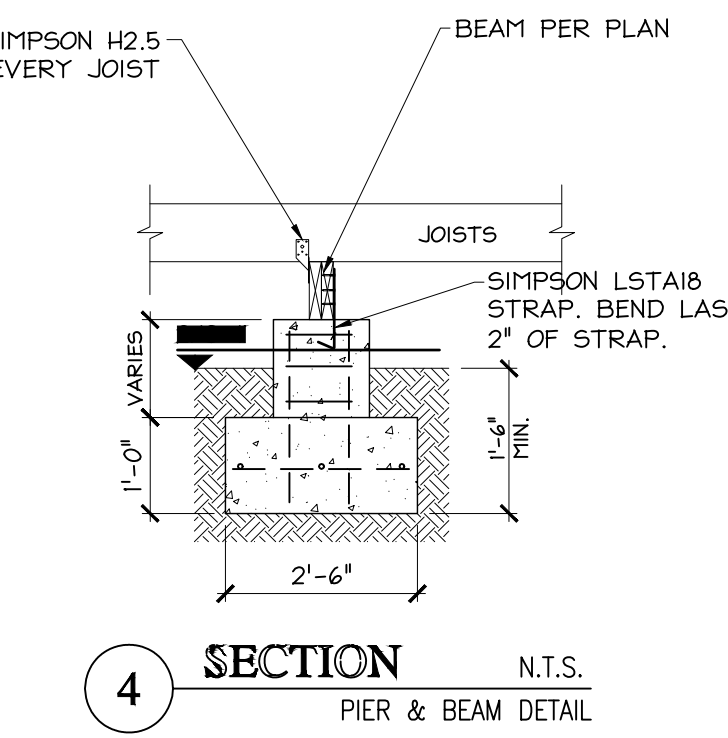
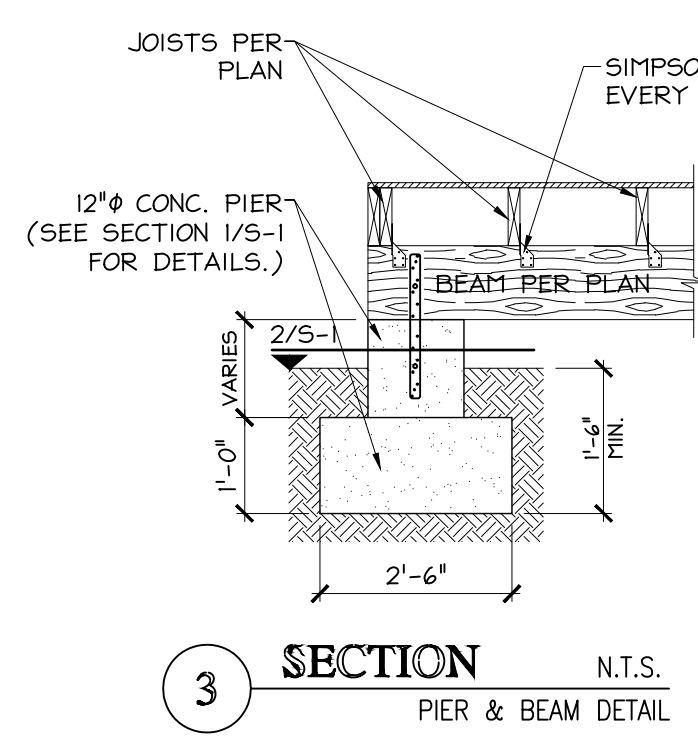
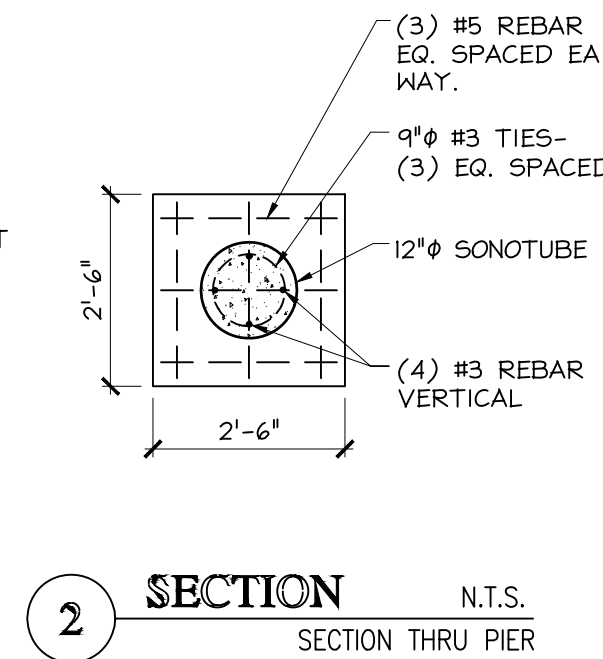
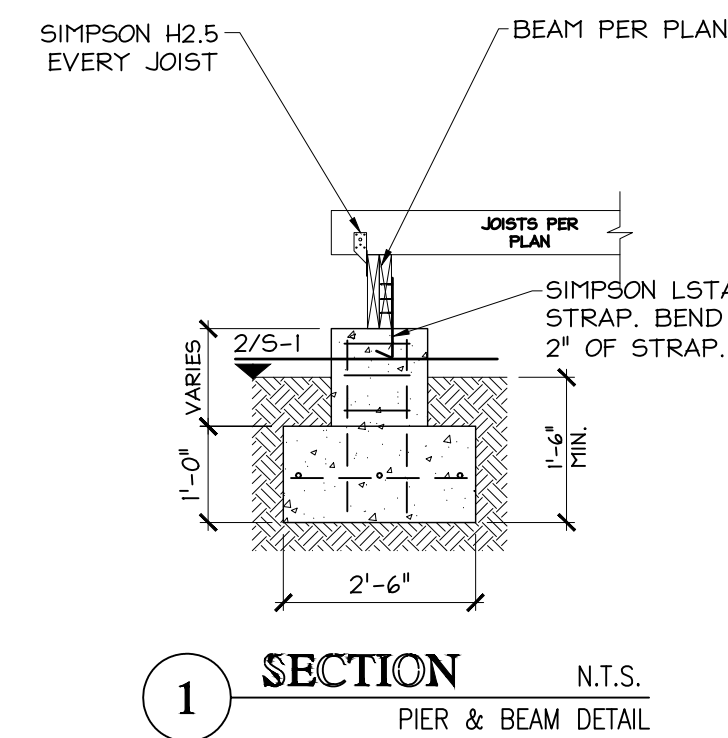

PIER FLOOR PLAN

11' x 17' - SCALE 1/8" = 1'-0"
24' x 36' - SCALE 1/4" = 1'-0"

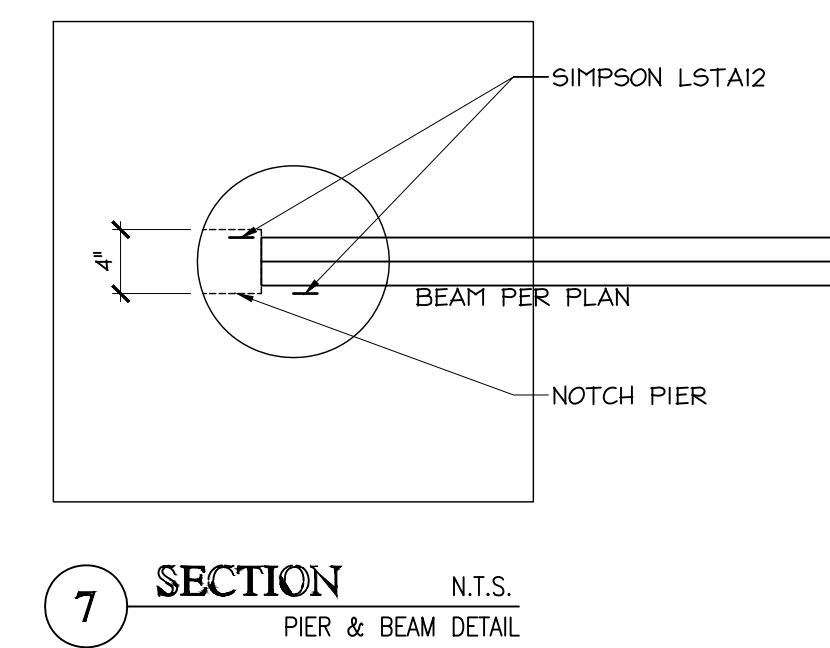
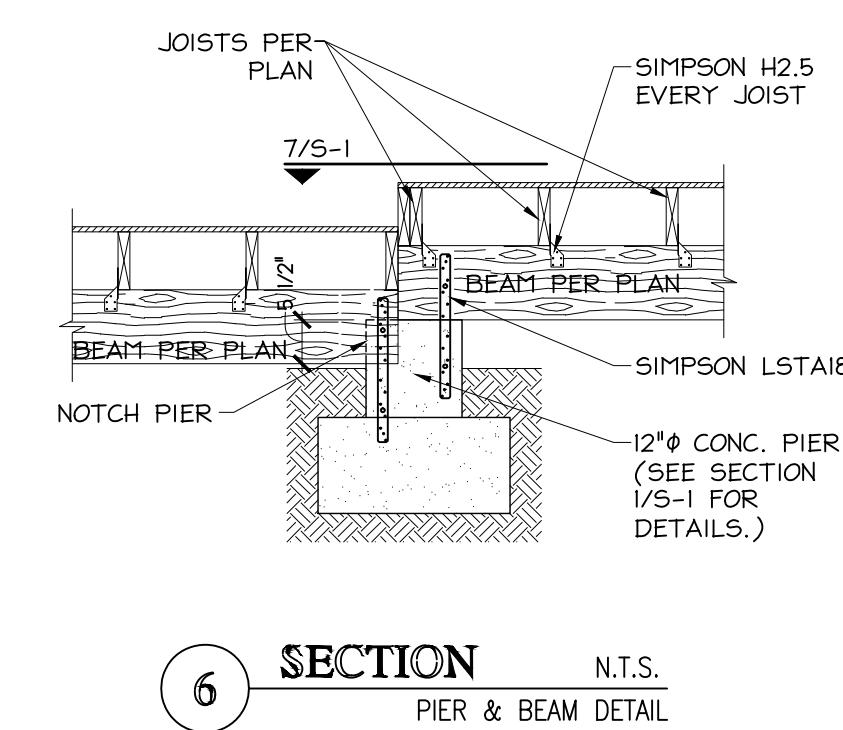



Phone 210.400.5617
frank.telles@gmail.com

NOTES

ATLAS ENGINEERING CONSULTANTS
FLOOR FRAMING, STRUCTURAL

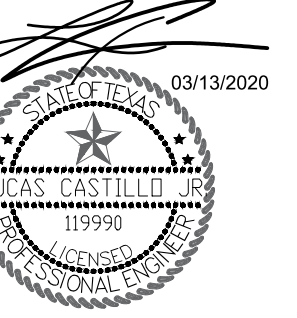

MENDIOLA'S RESIDENCE
120 CALLAGHAN AVE
SAN ANTONIO, TX

PLAN NO. 000
03/13/20

1ST FLOOR
CEILING
FRAMING
PLAN

SHEET

S-102

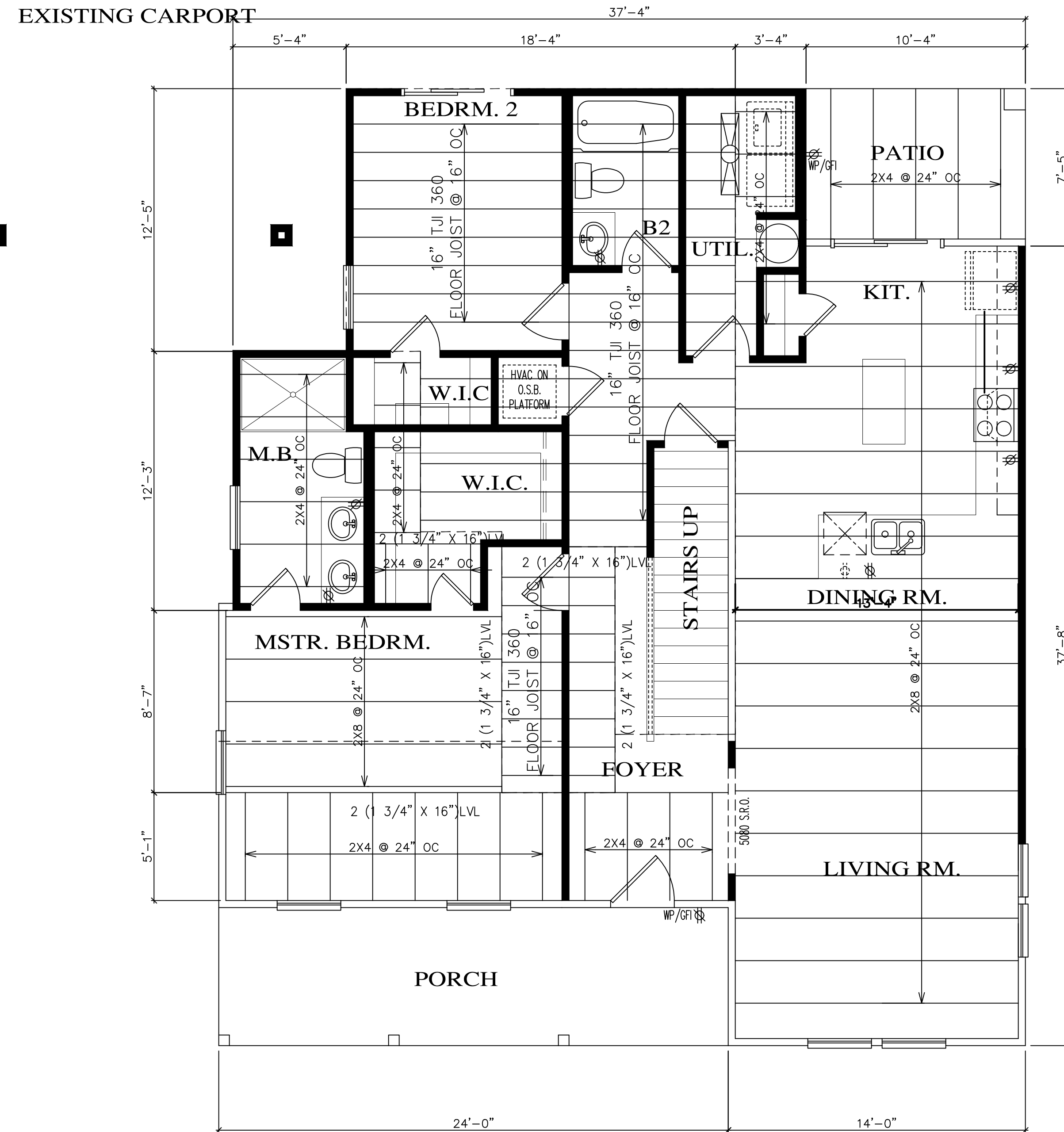
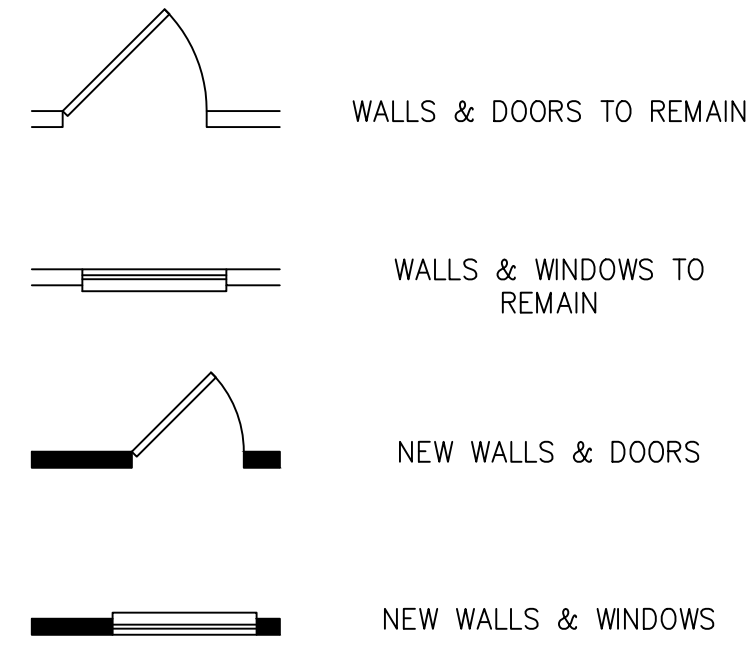

REMODEL
1ST FLOOR CEILING JOIST FRAMING
11" x 17" - SCALE 1/8" = 1'-0"
24" x 36" - SCALE 1/4" = 1'-0"

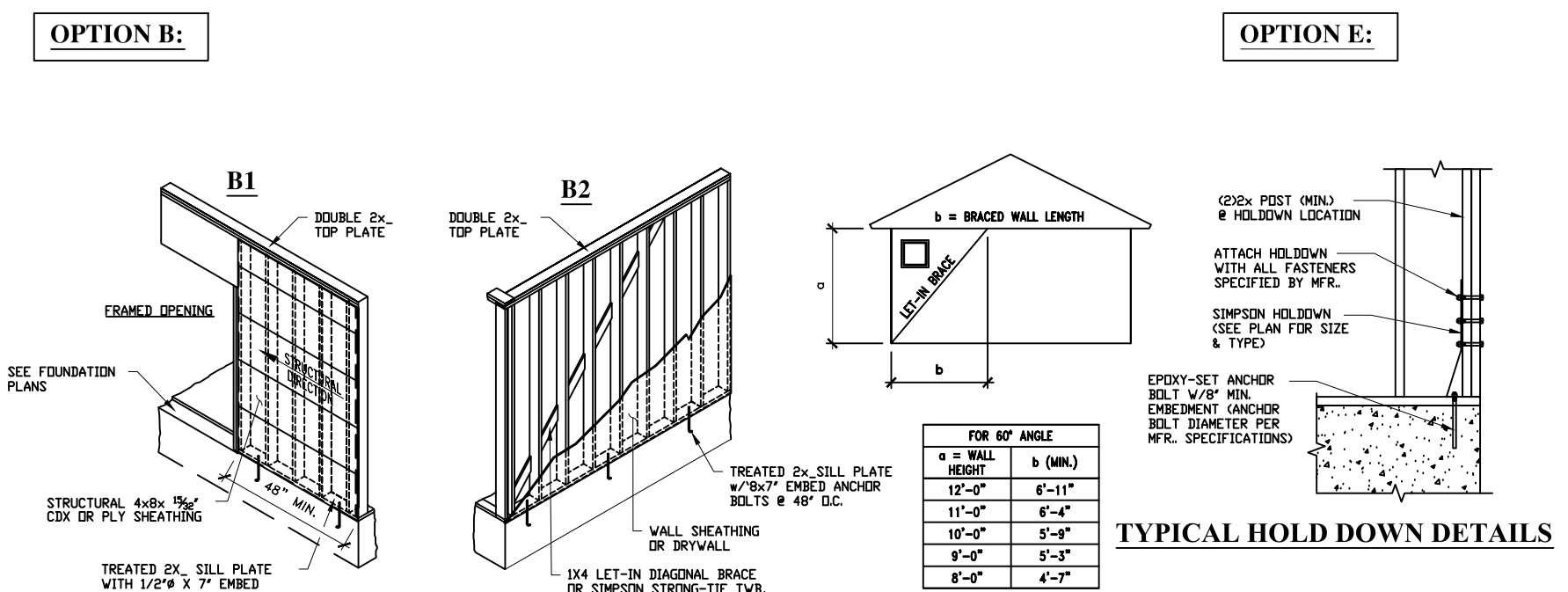
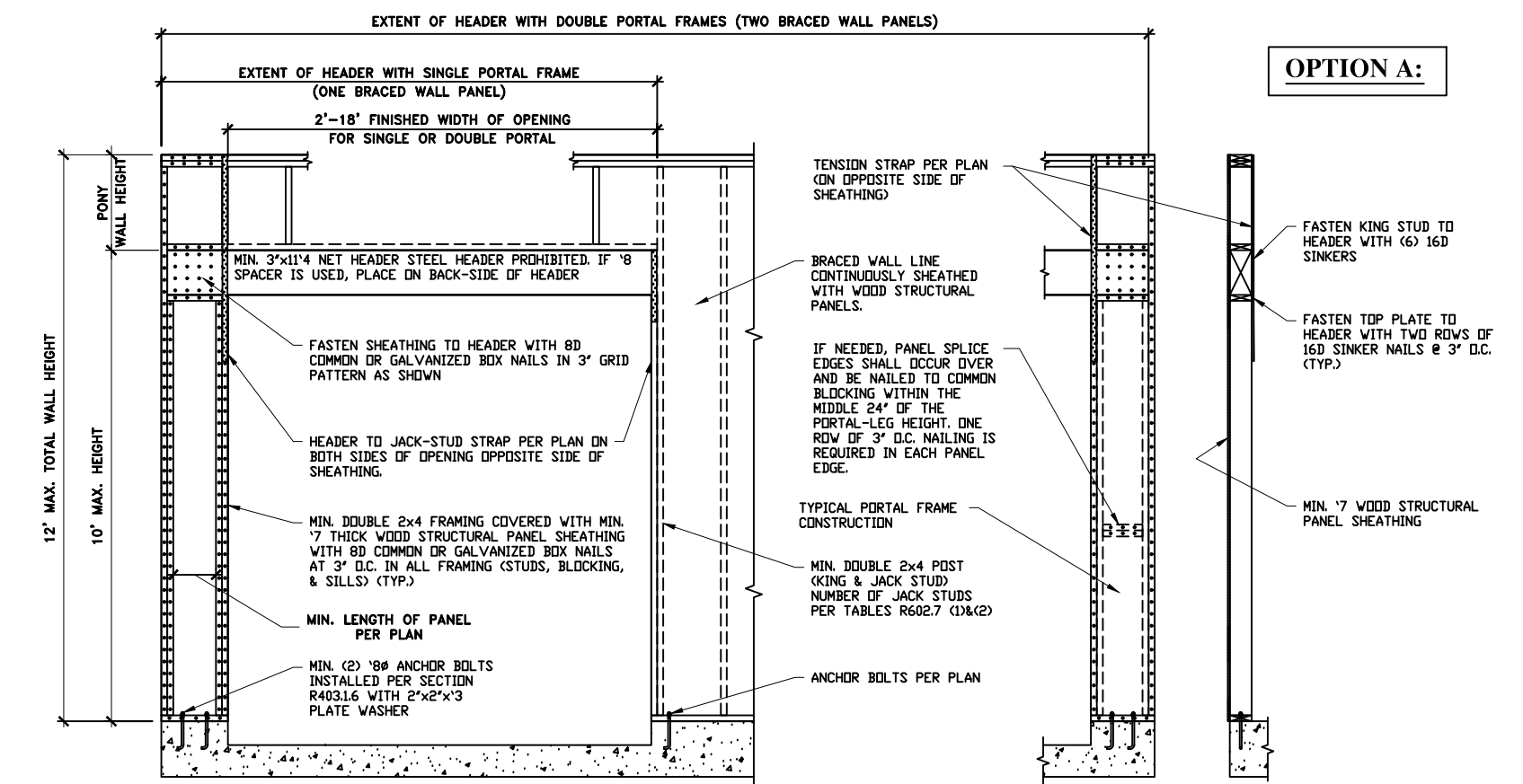

OPTION D: REQUIREMENTS FOR WOOD STRUCTURAL PANEL WALL SHEATHING USED TO RESIST WIND PRESSURES. Table with columns for MINIMUM NAIL, MINIMUM WOOD STRUCTURAL, MINIMUM PANEL SPACING, MAX. PANEL NAIL SPACING, ULTIMATE DESIGN WIND SPEED (MPH), and ULTIMATE DESIGN WIND EXPOSURE CATEGORY.

TABLE R602.10.5: LENGTH REQUIREMENTS FOR BRACED WALL PANELS WITH CONTINUOUS SHEATHING (INCHES). Table with columns for ADJACENT HEIGHT (INCHES), WEIGHT HEIGHT (FEET), and METHOD.

GENERAL WALL BRACING NOTES:
1. STUD SPACING SHALL NOT EXCEED 16" ON CENTERS. BRACING METHODS LIB, WSP, SFB, PWS, IRC 2003 SECTION R602.3.3.
2. NOMINAL 1"x4" CONTINUOUS DIAGONAL WOOD BRACE, LET IN FLATWISE INTO TOP AND BOTTOM CELLS PLATES AND INTERLOCKING STUDS. IRC BRACING METHOD L, IRC 2003 SECTION R602.3.3.
3. WOOD STRUCTURAL PANELS OR STRUCTURAL FIBER BOARD OR PARTICULATE BOARD SHEATHING, LAID UP WITH NAIL SHEET LONG AND APPLIED HORIZONTALLY. IRC BRACING METHODS WSP, SFB, & PWS.
SECTION R602.3.3.3.
4. STEEL BRACING: LET-IN KEYP BRACES BY SIMPSON STRONG-TIE, RCWB OR TVB FOR 16" ON CENTER STUD SPACING. WALL BRACING IN ACCORDANCE WITH IRC 2003 R602.3.3.3. ALTERNATE METHODS PER ICC NHER REPORT NHER468 AND ICC 2003 REPORT ECR209.
5. NAILING FOR PARTICULATE STRUCTURAL FIBER BOARD AND PARTICULATE BOARD SHEATHING SHALL BE IN ACCORDANCE WITH IRC SECTION R602.3.3. TABLE R602.3.3.3. WALL SPACING SHALL NOT EXCEED 6" ON CENTER AT EDGES, AND 12" ON CENTER AT INTERMEDIATE SUPPORTS.

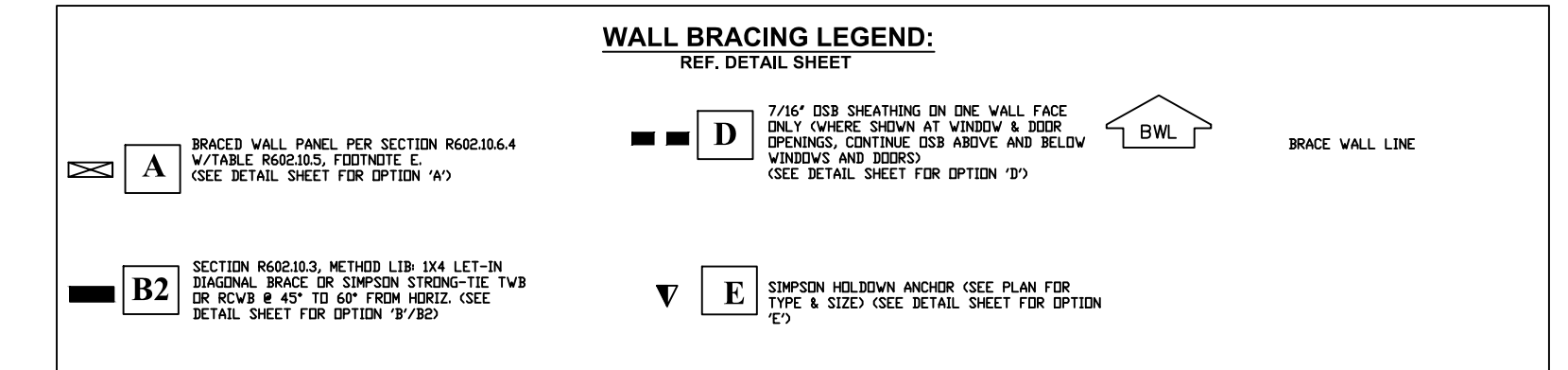

NOTES

ATLAS ENGINEERING CONSULTANTS
FLOOR PLAN, 2015
11/15/2015

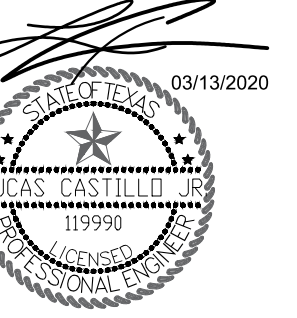

MENDIOLA'S RESIDENCE
120 CALLAGHAN AVE
SAN ANTONIO, TX

PLAN NO. 000
03/13/20

2ND LEVEL CEILING FRAMING PLAN

SHEET

S103

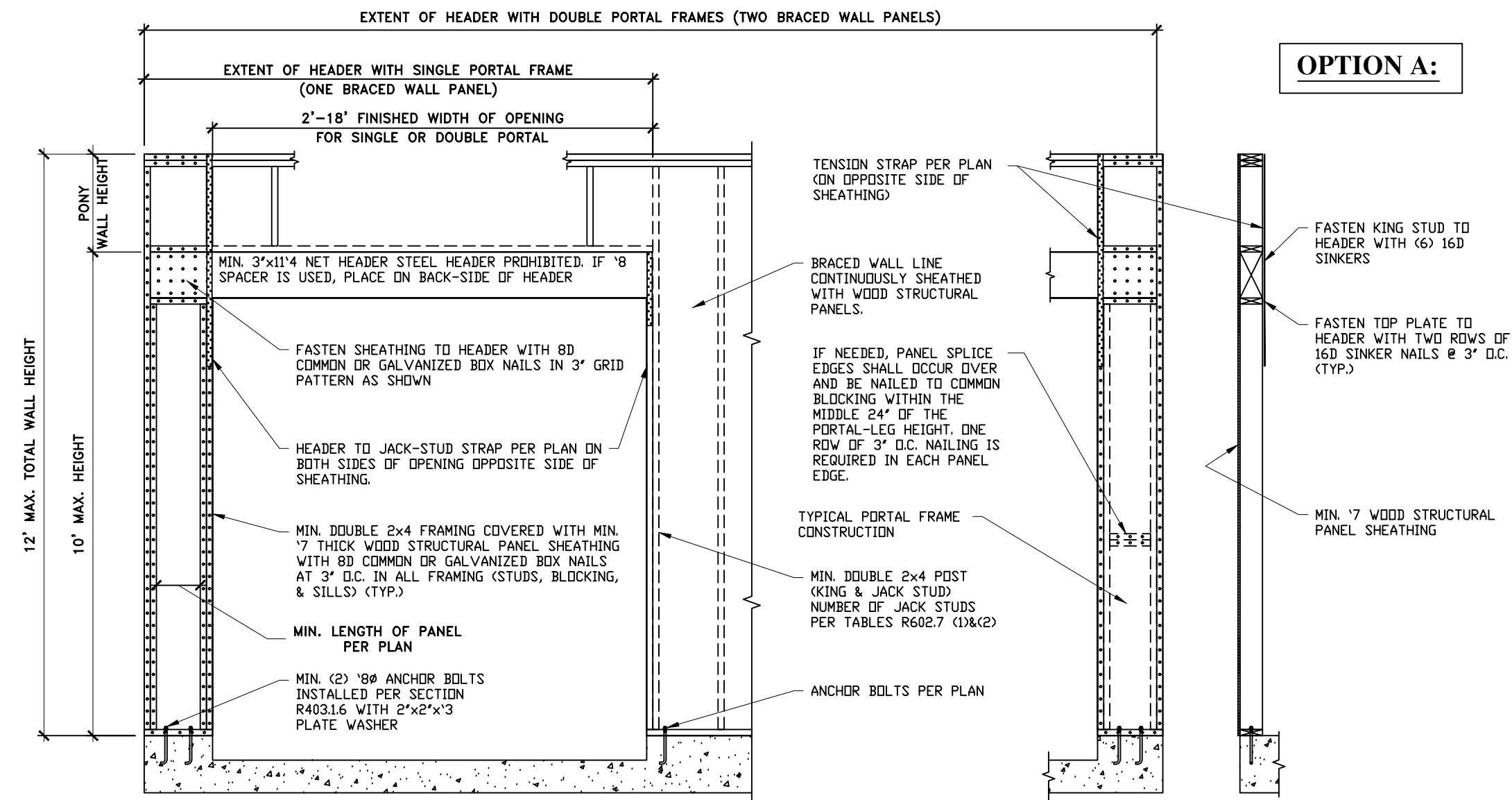

METHOD CS-PF CONTINUOUSLY SHEATHED SINGLE & DOUBLE PORTAL FRAME CONSTRUCTION AS PER THE 2015 IRC

OPTION B:

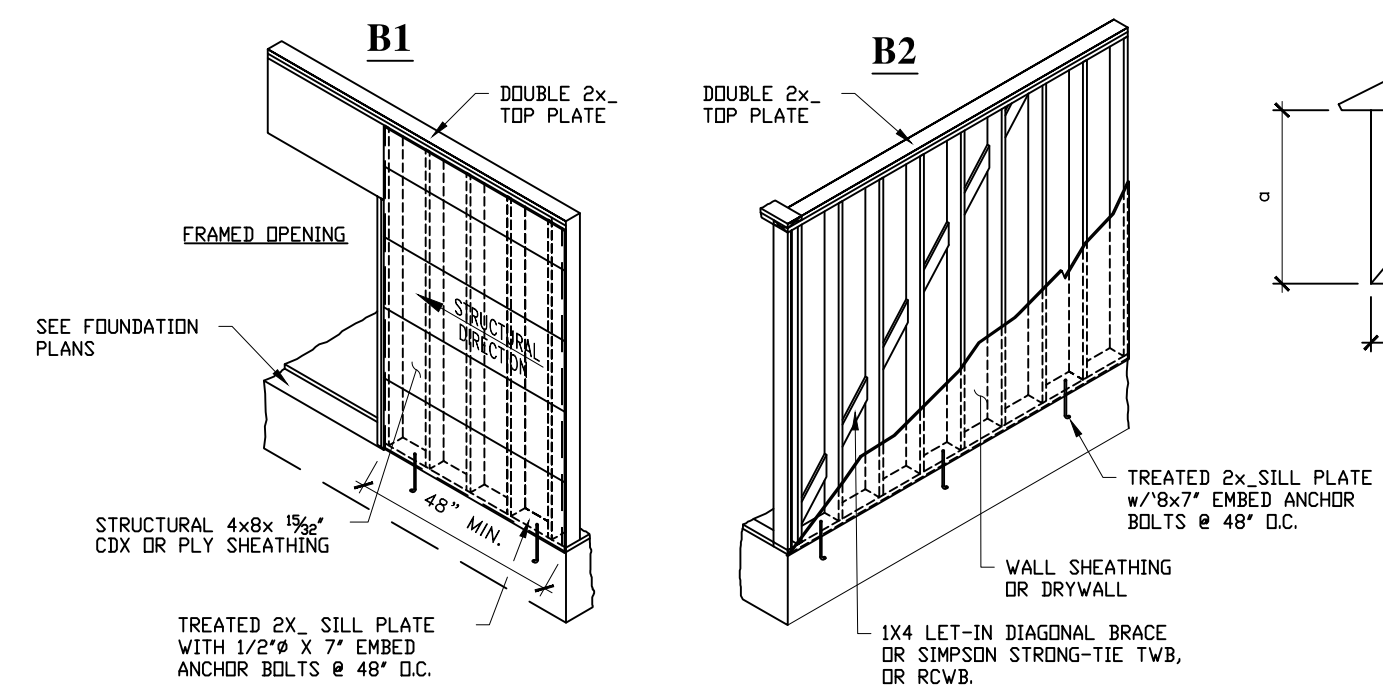

TYPICAL BRACING FOR CONVENTIONAL RESIDENTIAL CONSTRUCTION

OPTION E:

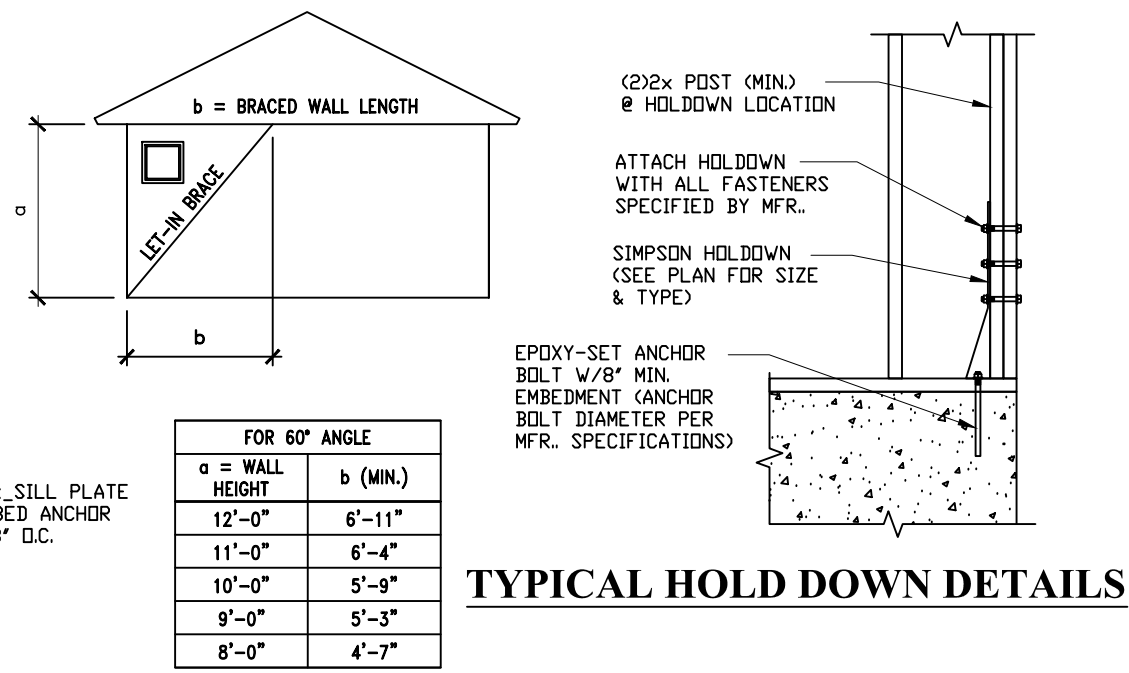

TYPICAL HOLD DOWN DETAILS

OPTION D:

IRC 2015 - TABLE R602.3(3)

REQUIREMENTS FOR WOOD STRUCTURAL PANEL WALL SHEATHING USED TO RESIST WIND PRESSURES

MINIMUM NAIL SIZE	MINIMUM WOOD STRUCTURAL PANEL SPAN (INCHES)	MINIMUM WOOD STRUCTURAL PANEL RATING	MINIMUM NOMINAL PANEL THICKNESS (INCHES)	MAX. WALL STUD SPACING (INCHES)	PANEL NAIL SPACING			ULTIMATE DESIGN WIND SPEED (MPH)		
					EDGES (INCHES O.C.)	FIELD (INCHES O.C.)	WIND EXPOSURE CATEGORY	B	C	D
6d COMMON (2.0 x 0.113")	1.5	24/0	3/8	16	6	12	140	115	110	
				16	6	12	170	140	135	
8d COMMON (2.5 x 0.131")	1.75	24/16	7/16	24	6	12	140	115	110	

GENERAL WALL BRACING NOTES:

- STUD SPACING SHALL NOT EXCEED 16" ON CENTERS; BRACING METHODS LIB, WSP, SFB, PBS, IRC 2015 SECTION R602.10.3
- NOMINAL 1x4" CONTINUOUS DIAGONAL WOOD BRACE, LET IN FLATWISE INTO TOP AND BOTTOM (SILL) PLATES AND INTERVENING STUDS; IRC BRACE METHOD 1, IRC 2015 SECTION R602.10.3
- WOOD STRUCTURAL PANELS OR STRUCTURAL FIBER BOARD, OR PARTICLE BOARD SHEATHING, LAID UP WITH 4x8 SHEET LONG AXIS APPLIED HORIZONTALLY; IRC BRACING METHODS WSP, SFB, & PBS, SECTION R602.10.3
- STEEL DIAGONAL LET-IN KERF BRACES BY SIMPSON STRONG-TIE (RCWB OR TW8 FOR 16" ON CENTERS; STUD SPACING WALL BRACING IN ACCORDANCE WITH IRC 2015 R602.10). ALTERNATE METHODS PER ICC NER REPORT NER422, AND ICC ER REPORT ER5709.
- NAILING FOR PLYWOOD, STRUCTURAL FIBER BOARD, AND PARTICLE BOARD SHEATHING SHALL BE IN ACCORDANCE WITH IRC SECTION R602.3, TABLE R602.3(3); NAIL SPACING SHALL NOT TO EXCEED 6" ON CENTER AT EDGES, AND 12" ON CENTER AT INTERMEDIATE SUPPORTS.

TABLE R602.10.5

LENGTH REQUIREMENTS FOR BRACED WALL PANELS WITH CONTINUOUS SHEATHING (INCHES)

METHOD	ADJACENT CLEAR OPENING HEIGHT (INCHES)	WEIGHT HEIGHT (FEET) ^a			
		8	9	10	11
CS-WSP	64	24	27	30	33
	68	26	27	30	33
	72	27	27	30	33
	76	30	29	30	33
	80	32	30	30	33
	84	35	32	32	33
	88	38	35	33	33
	92	43	37	35	35
	96	48	41	38	36
	100	-	44	40	38
	104	-	49	43	40
	108	-	54	46	43
	112	-	-	50	45
	116	-	-	55	48
120	-	-	60	52	
124	-	-	-	56	
132	-	-	-	66	
144	-	-	-	72	
CS-0	≤20	24	27	30	33
CS-PF	≤20	16	18	20	22

FDR S1: 1 inch=25.4mm, 1 Foot=304.8mm
6. INTERPOLATION SHALL BE PERMITTED.

WALL BRACING LEGEND:
REF. DETAIL SHEET

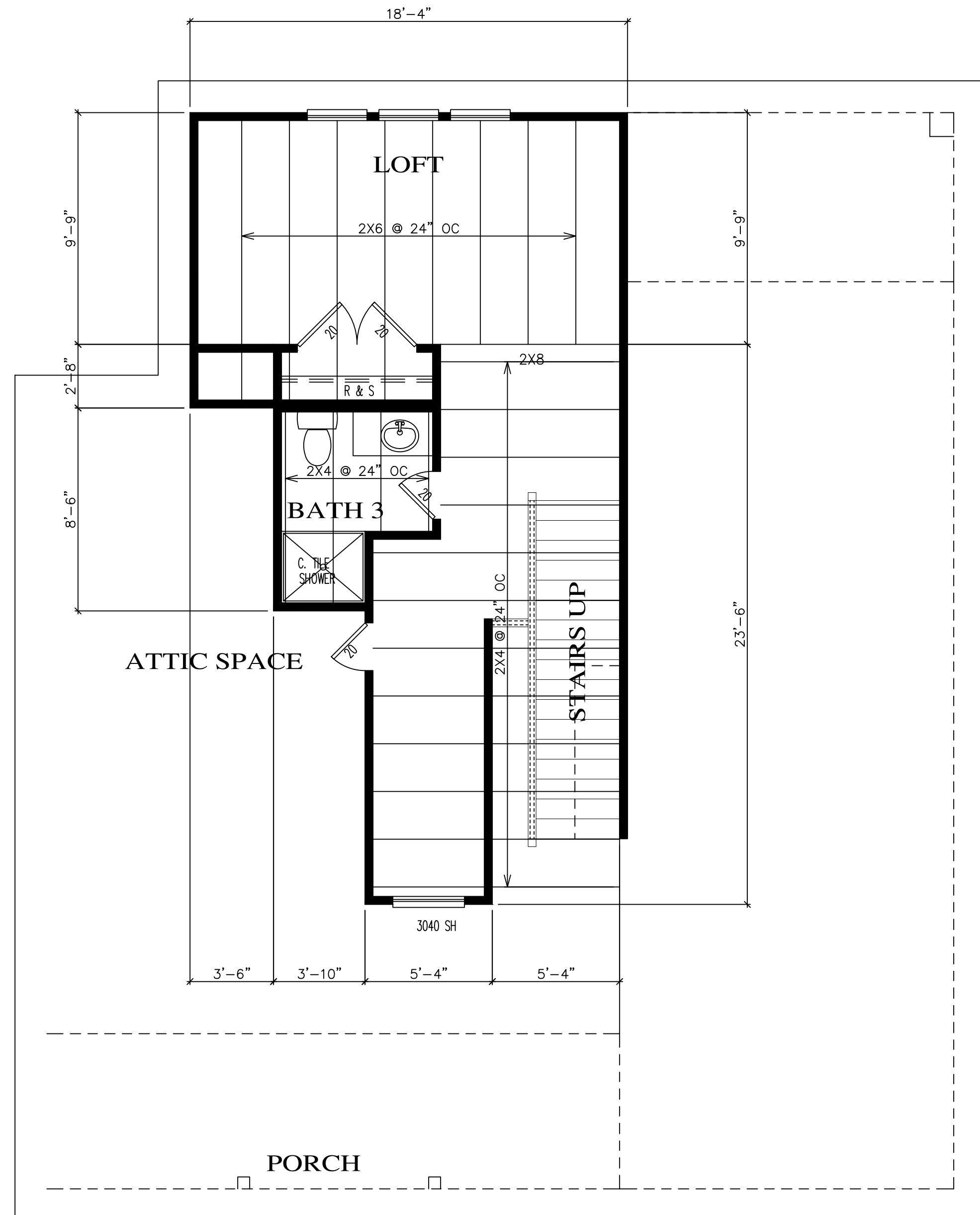
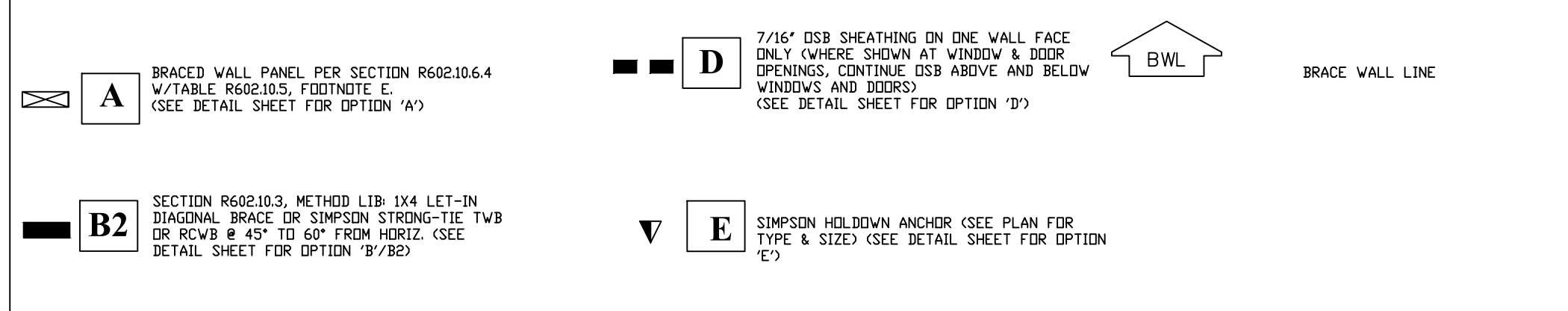

LOFT FLOOR PLAN

NOTES

ATLAS ENGINEERING CONSULTANTS
FREDERICK, TEXAS



MENDIOLA'S RESIDENCE
120 CALLAGHAN AVE
SAN ANTONIO, TX

PLAN NO. 000
03/13/20

FIRST LEVEL
CEILING
JOIST

SHEET

S-104

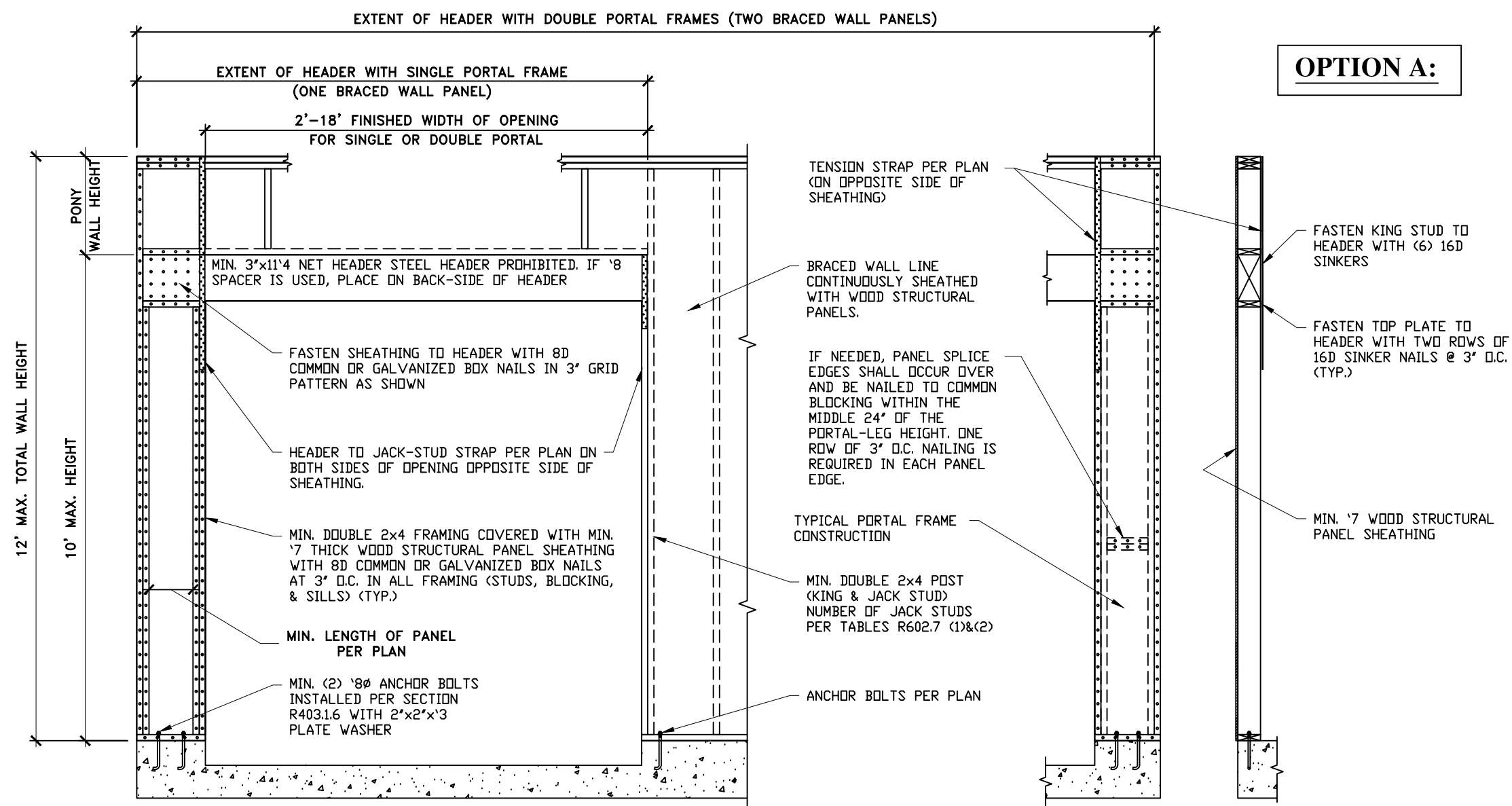

METHOD CS-PF CONTINUOUSLY SHEATHED SINGLE & DOUBLE PORTAL FRAME CONSTRUCTION AS PER THE 2015 IRC

OPTION B:

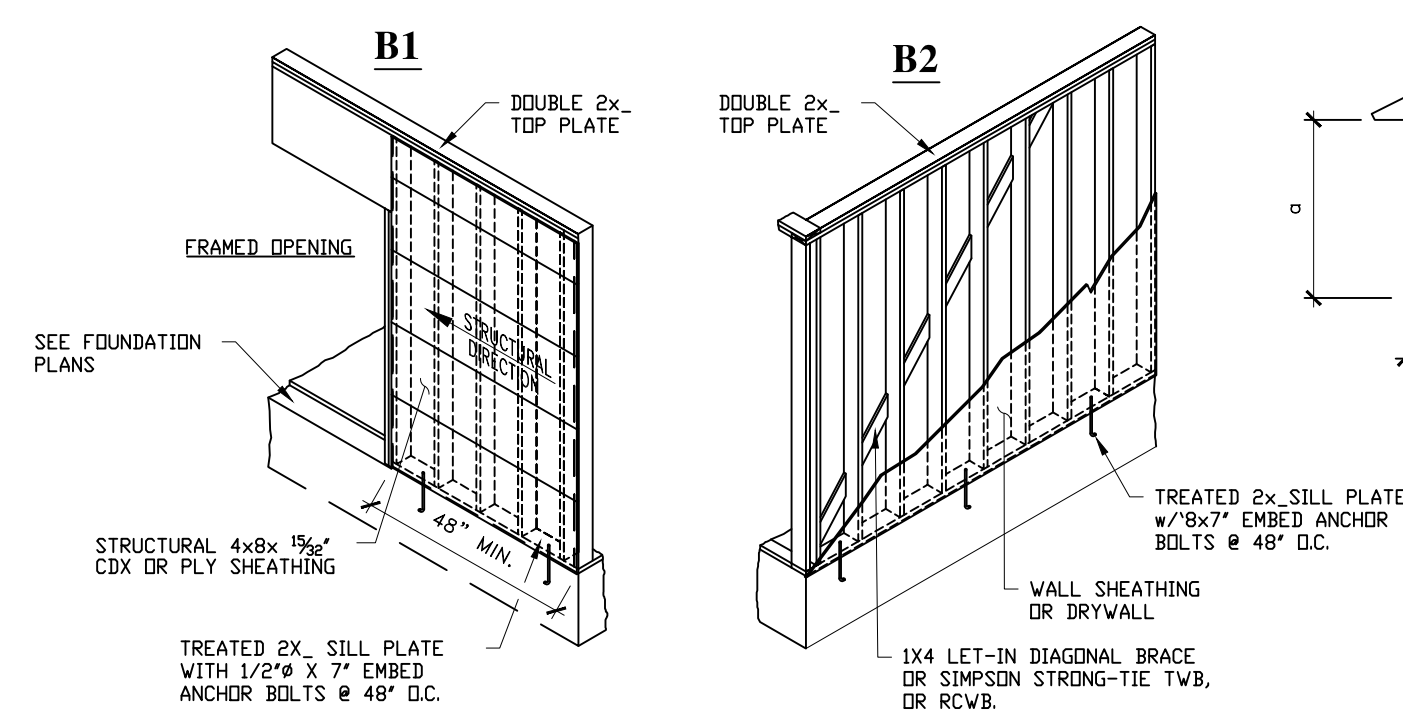

TYPICAL BRACING FOR CONVENTIONAL RESIDENTIAL CONSTRUCTION

OPTION D:

IRC 2015 - TABLE R602.3(3)
REQUIREMENTS FOR WOOD STRUCTURAL PANEL WALL SHEATHING USED TO RESIST WIND PRESSURES

SIZE	PENETRATION (INCHES)	MINIMUM WOOD STRUCTURAL PANEL SPAN RATING	MINIMUM NOMINAL PANEL THICKNESS (INCHES)	MAX. WALL STUD SPACING (INCHES)	PANEL NAIL SPACING		ULTIMATE DESIGN WIND SPEED (MPH)		
					EDGES (INCHES O.C.)	FIELD (INCHES O.C.)	WIND EXPOSURE CATEGORY		
							B	C	D
6d COMMON (2.0 x 0.131")	1.5	24/0	3/8	16	6	12	140	115	110
6d COMMON (2.5 x 0.131")	1.75	24/16	7/16	16	6	12	170	140	135
				24	6	12	140	115	110

GENERAL WALL BRACING NOTES:

- STUD SPACING SHALL NOT EXCEED 16" ON CENTERS. BRACING METHODS LIB, VSP, SFB, PBS, IRC 2015 SECTION R602.10.3.
- NOMINAL 1"x4" CONTINUOUS DIAGONAL WOOD BRACE, LET IN FLATWISE INTO TOP AND BOTTOM (SILL) PLATES AND INTERVENING STUDS. IRC BRACE METHOD 1, IRC 2015 SECTION R602.10.3.
- WOOD STRUCTURAL PANELS OR STRUCTURAL FIBER BOARD, OR PARTICLE BOARD SHEATHING, LAID UP WITH 4X8 SHEET LONG AXIS APPLIED HORIZONTALLY, IRC BRACING METHODS VSP, SFB, & PBS, SECTION R602.10.3.
- STEEL DIAGONAL LET-IN KEYP BRACES BY SIMPSON STRONG-TIE (RCWB OR TWB FOR 16" ON CENTER STUD SPACING) WALL BRACING IN ACCORDANCE WITH IRC 2015 R602.10. ALTERNATE METHODS PER ICC NER REPORT NER422, AND ICC ER REPORT ER5709.
- NAILING FOR PLYWOOD, STRUCTURAL FIBER BOARD, AND PARTICLE BOARD SHEATHING SHALL BE IN ACCORDANCE WITH IRC SECTION R602.3, TABLE R602.3(3). NAIL SPACING SHALL NOT TO EXCEED 6" ON CENTER AT EDGES, AND 12" ON CENTER AT INTERMEDIATE SUPPORTS.

WALL BRACING LEGEND:
REF. DETAIL SHEET

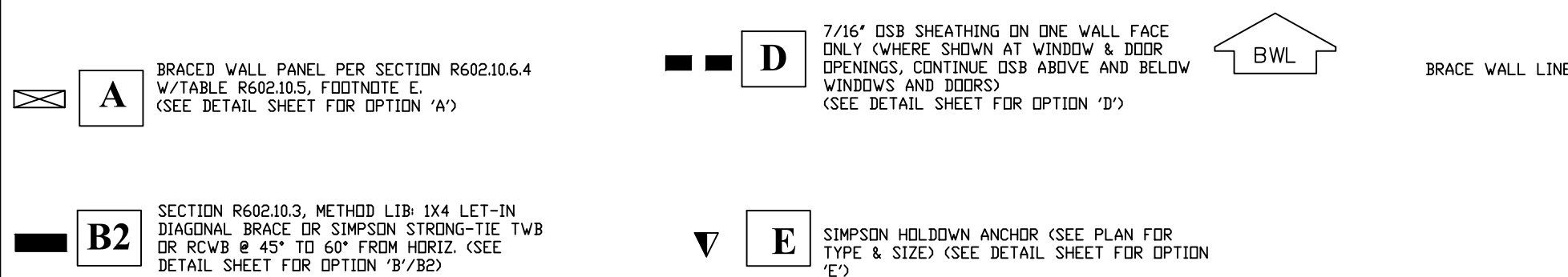

OPTION E:

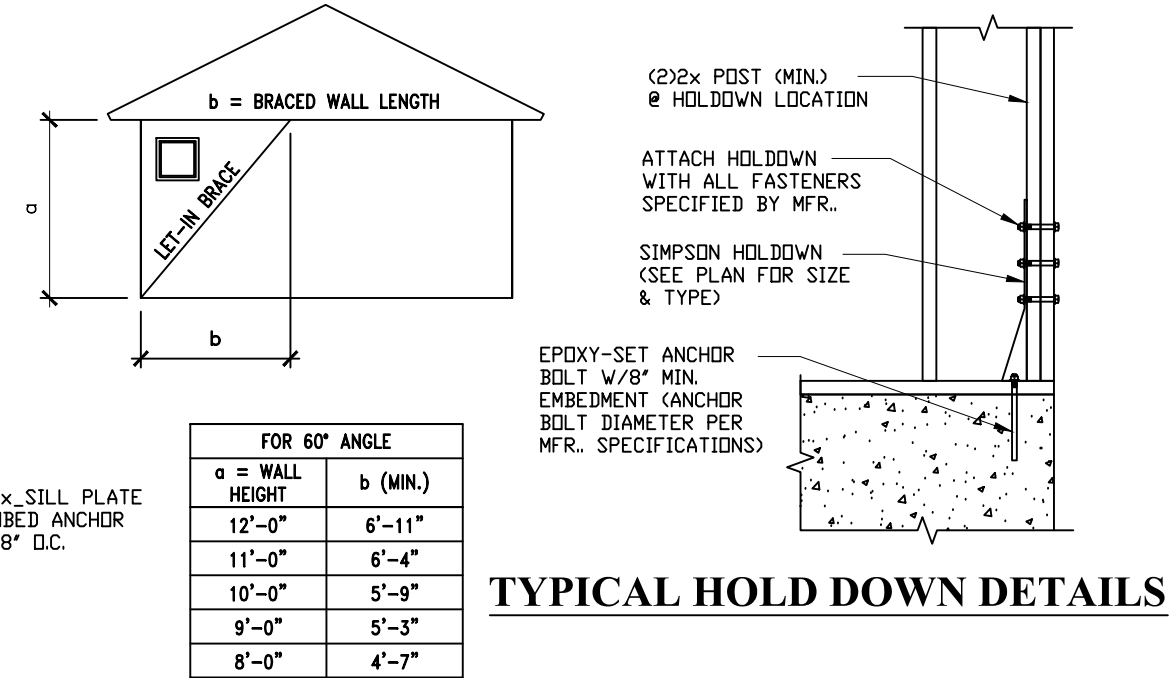

TYPICAL HOLD DOWN DETAILS

TABLE R602.10.5
LENGTH REQUIREMENTS FOR BRACED WALL PANELS WITH CONTINUOUS SHEATHING (INCHES)

METHOD	ADJACENT CLEAR OPENING HEIGHT (INCHES)	WEIGHT HEIGHT (FEET)*				
		8	9	10	11	12
CS-VSP	64	24	27	30	33	36
	68	26	27	30	33	36
	72	27	27	30	33	36
	76	30	29	30	33	36
	80	32	30	30	33	36
	84	35	32	32	33	36
	88	38	35	33	33	36
	92	43	37	35	35	36
	96	48	41	38	36	36
	100	-	44	40	38	38
	104	-	49	43	40	39
	108	-	54	46	43	41
	112	-	-	50	45	43
	116	-	-	55	48	45
120	-	-	60	52	48	
124	-	-	-	56	51	
132	-	-	-	66	58	
144	-	-	-	-	72	
CS-S	≤20	24	27	30	33	36
CS-PF	≤20	16	18	20	22	24

FOR S1: 1 Inch=25.4mm, 1 Foot=304.8mm
a. INTERPOLATION SHALL BE PERMITTED.

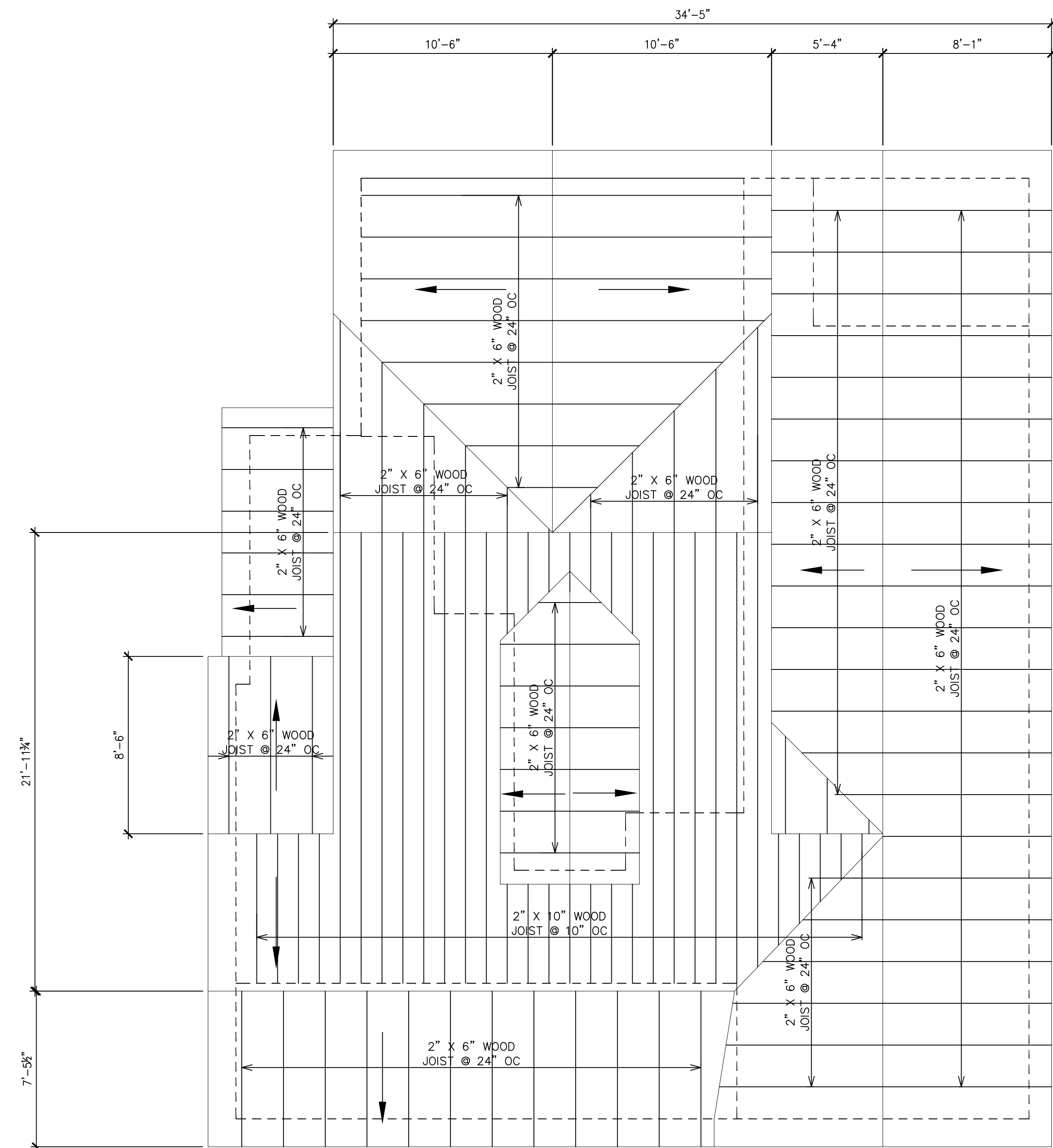

ROOF FRAMING PLAN

11" x 17" - SCALE 1/8" = 1'-0"
24" x 36" - SCALE 1/4" = 1'-0"



Phone 210.400.5617
frank.telles@gmail.com

NOTES

ATLAS ENGINEERING CONSULTANTS
TYPE FIRM NO. 17867
11000 N. LOOP WEST, SUITE 1000
HOUSTON, TEXAS 77040
www.atlas-engineering.com

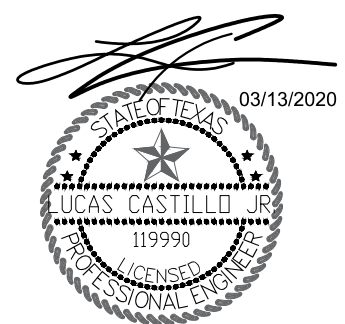

MENDIOLA'S RESIDENCE
120 CALLAGHAN AVE
SAN ANTONIO, TX

PLAN NO.
000
03/13/13

FRAMING
DETAILS

SHEET

S-106

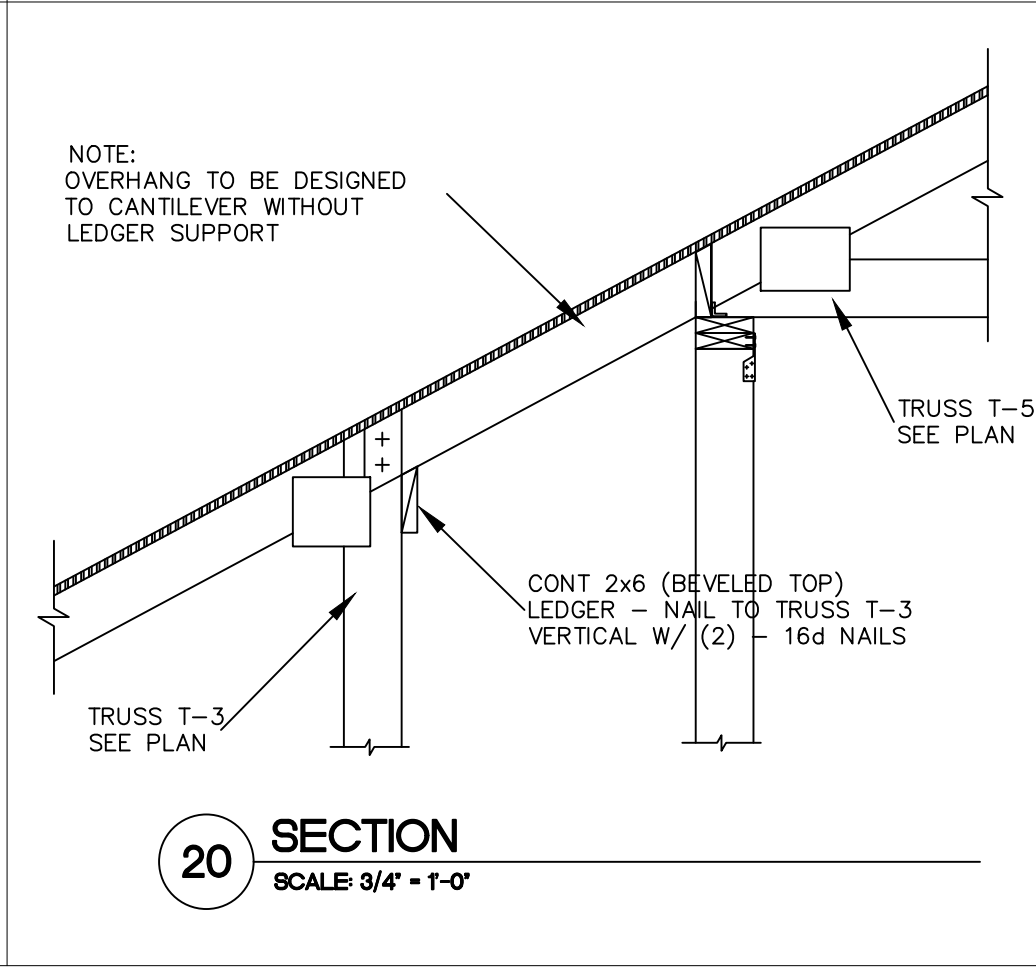
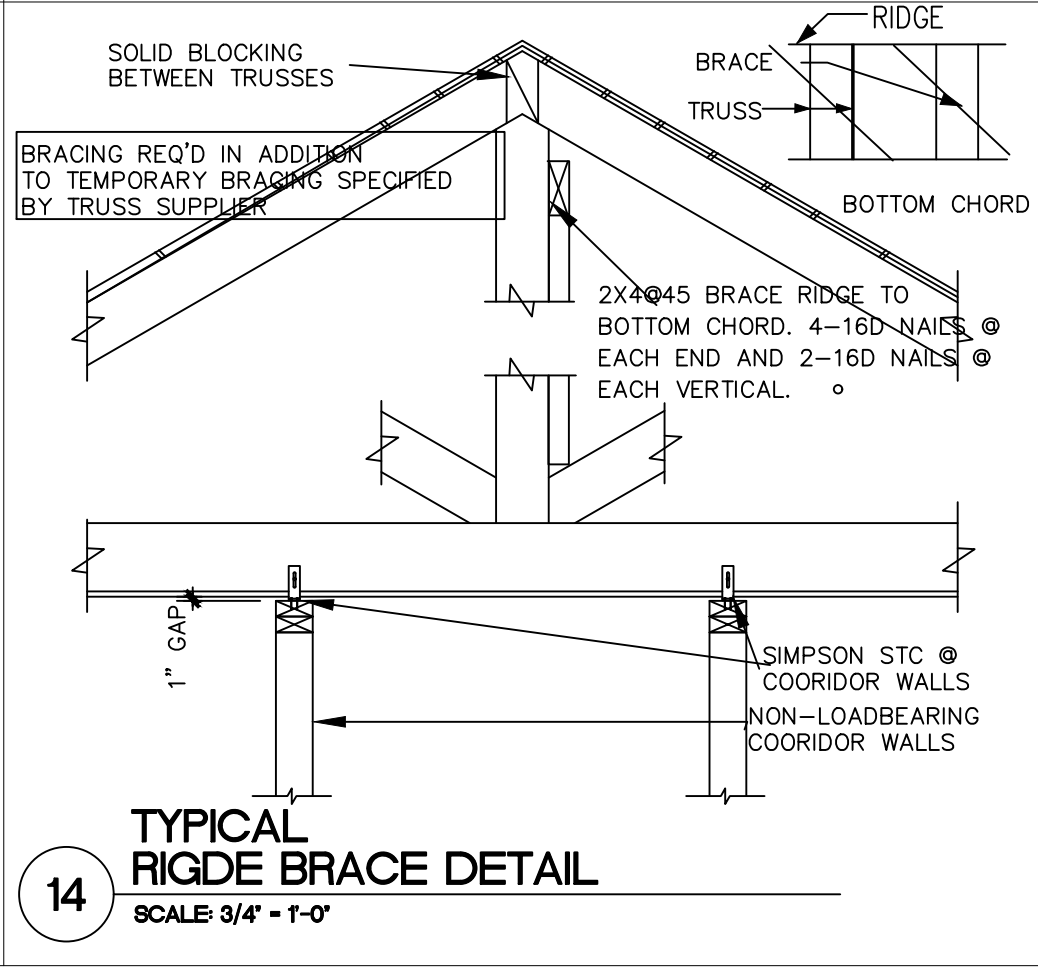
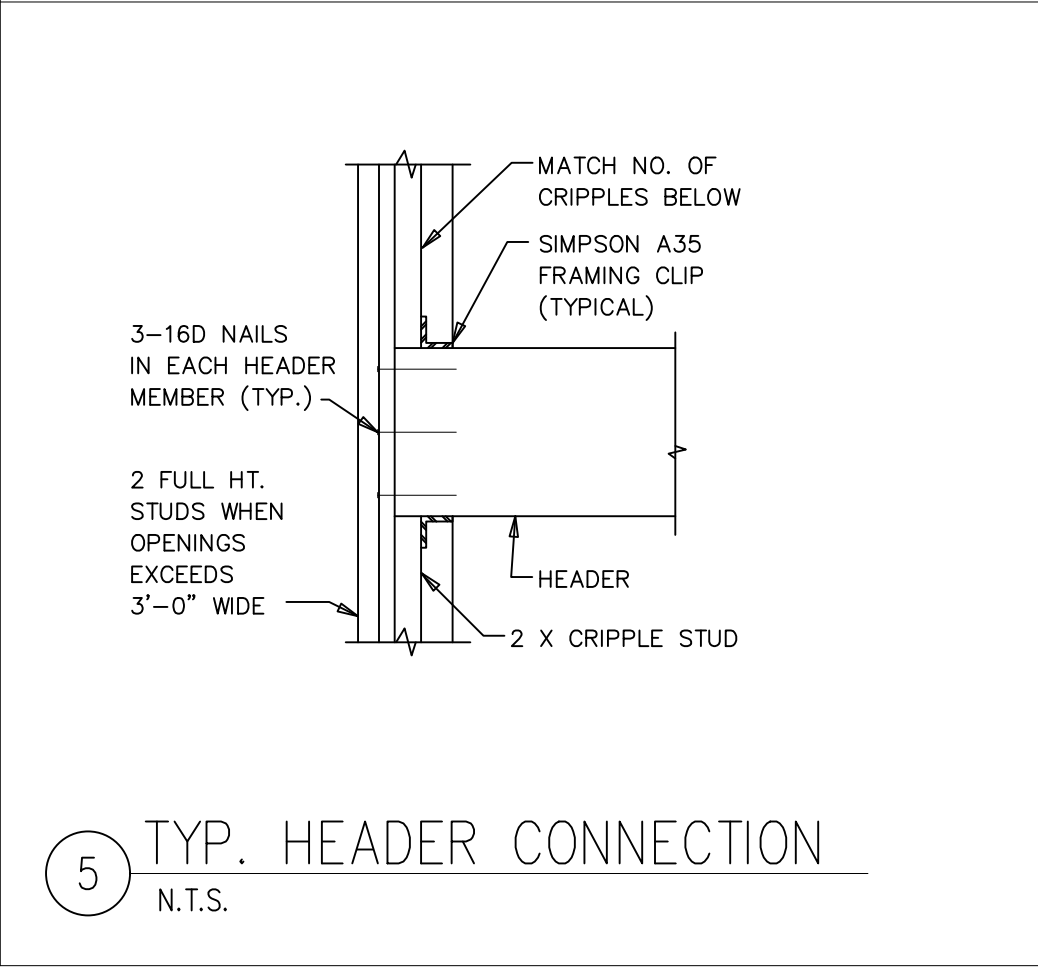
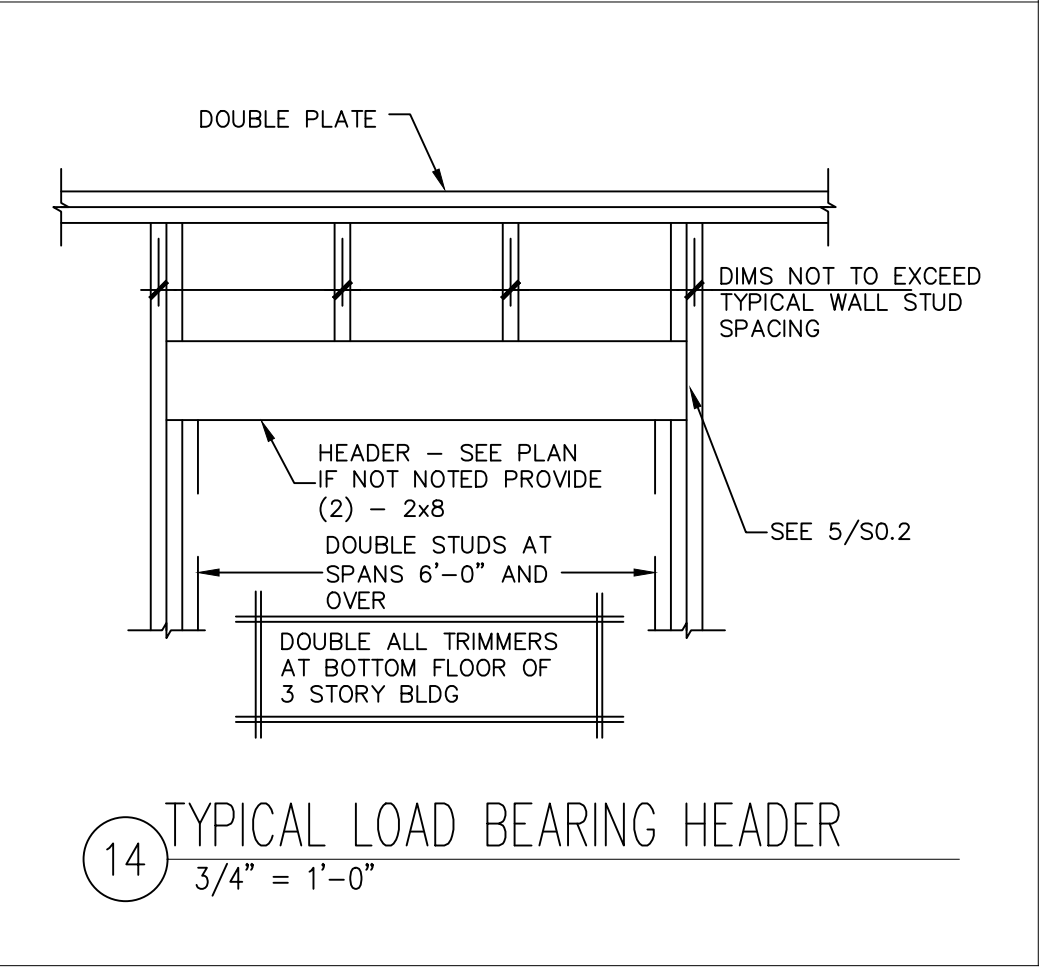
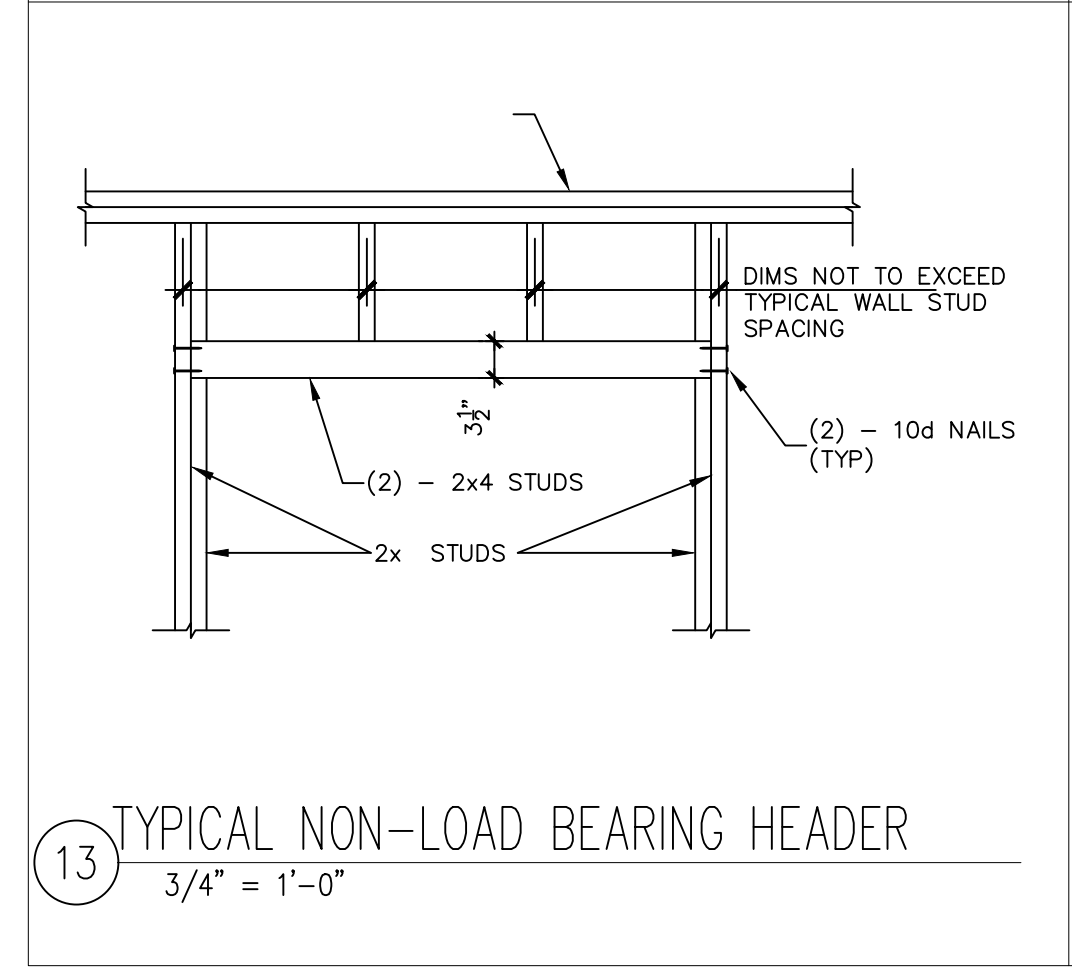
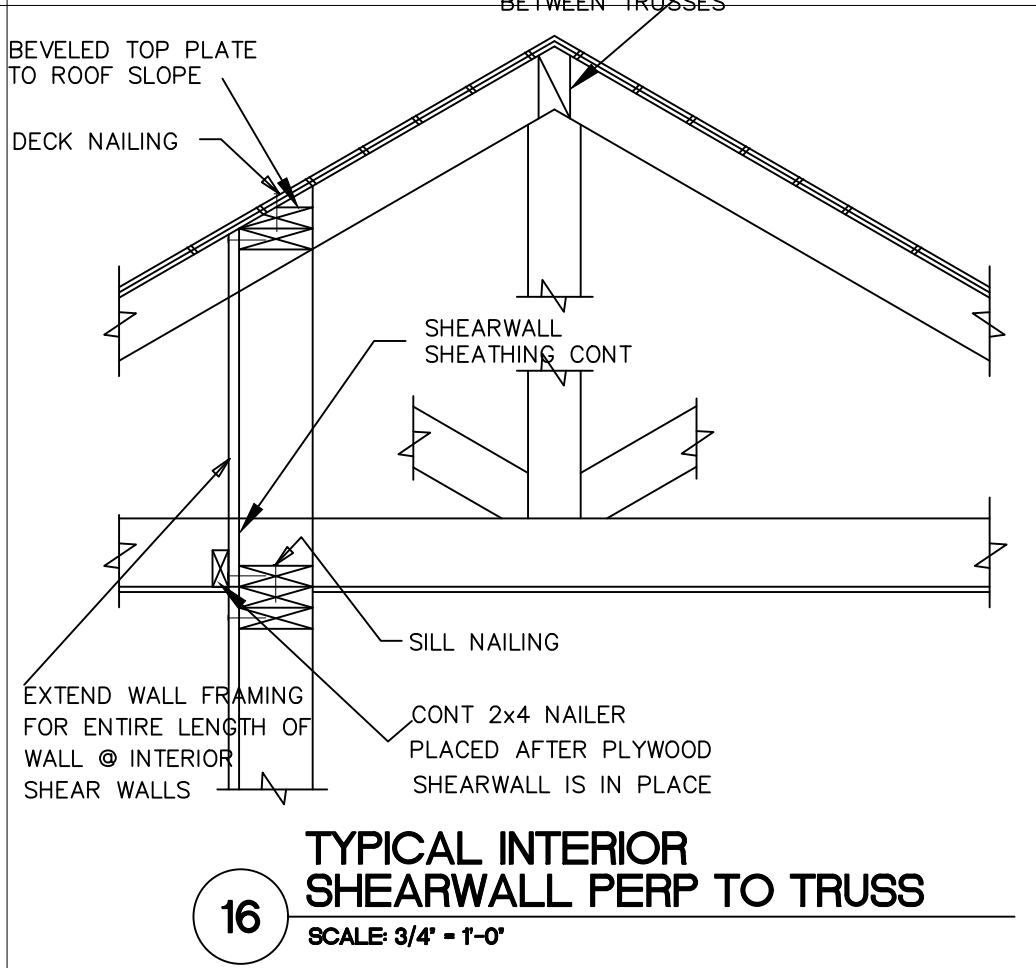
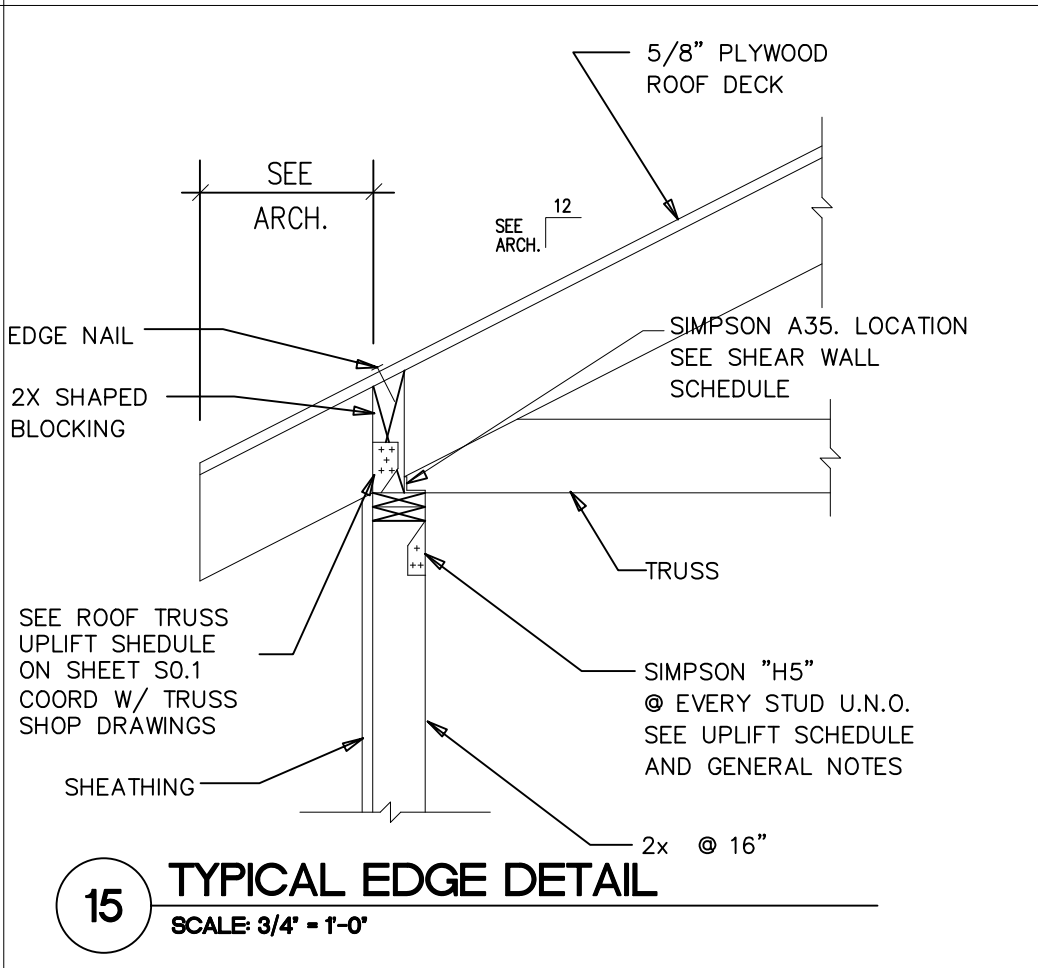
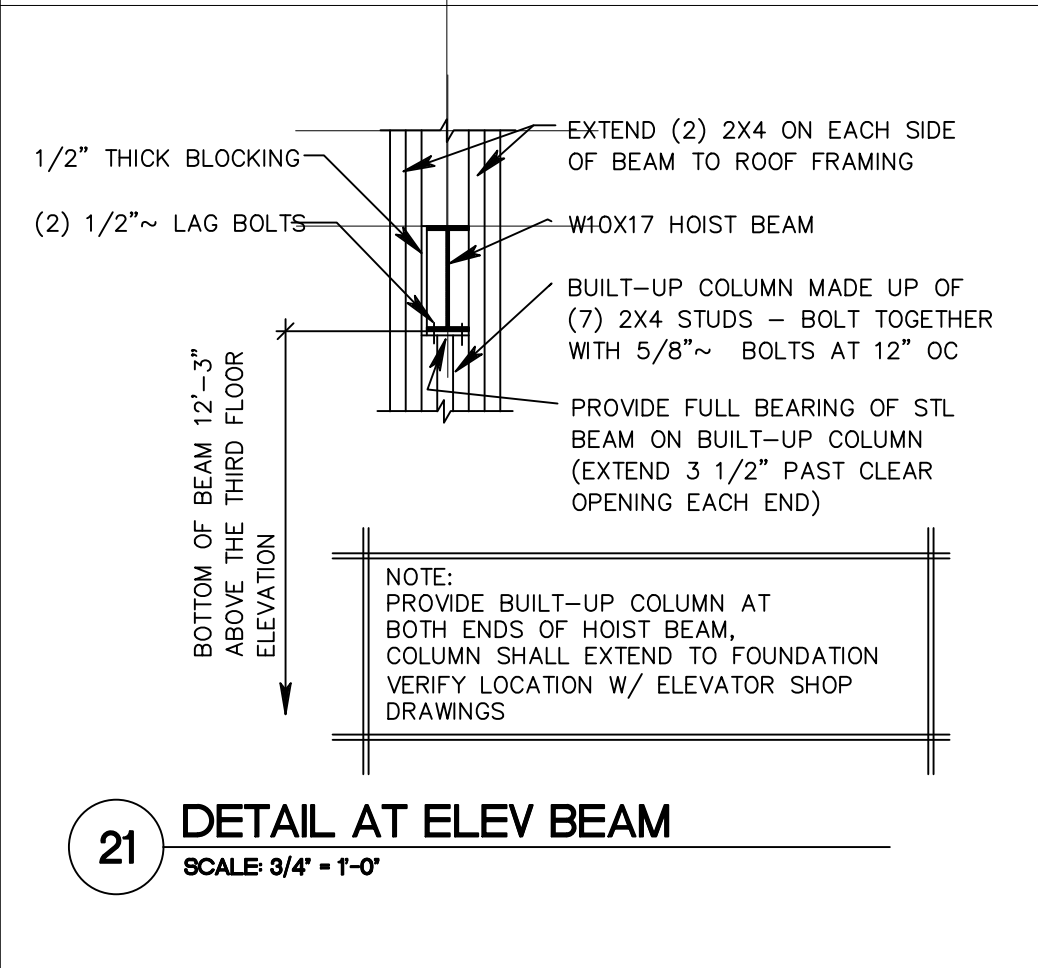
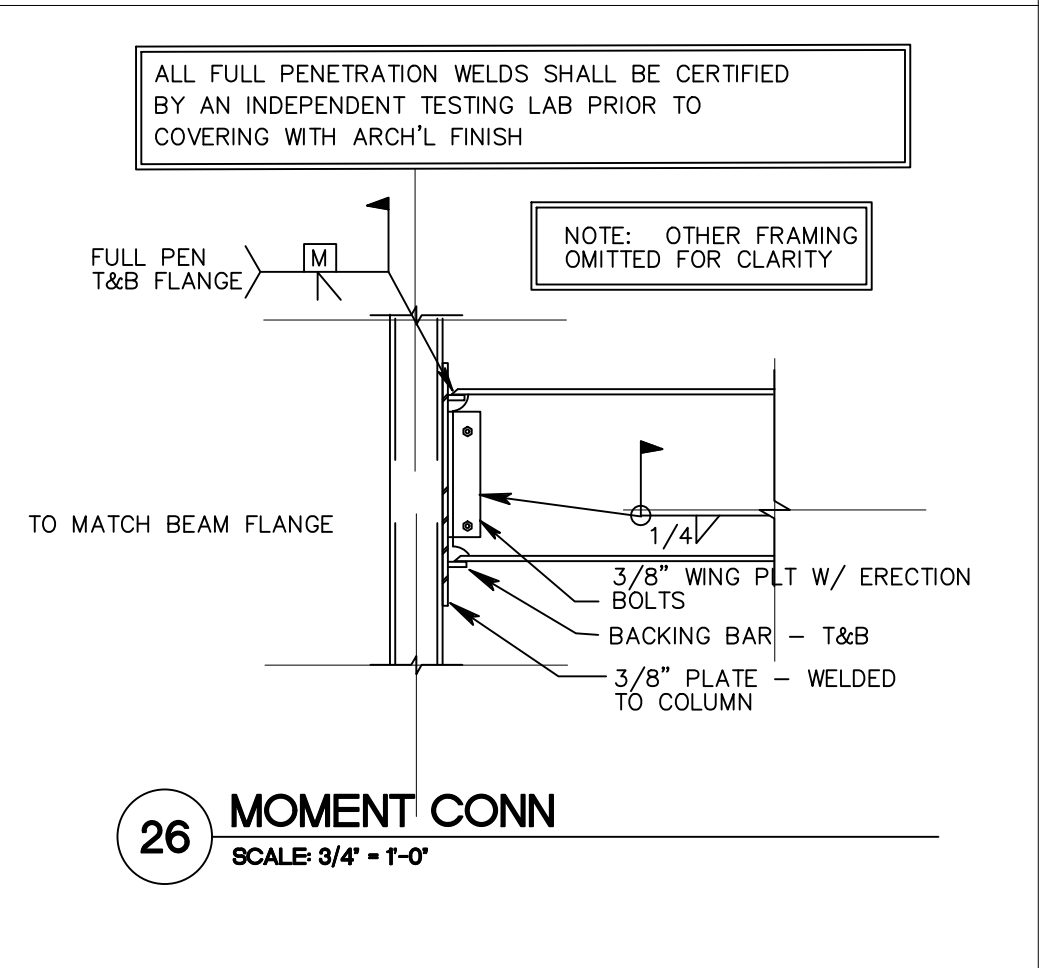
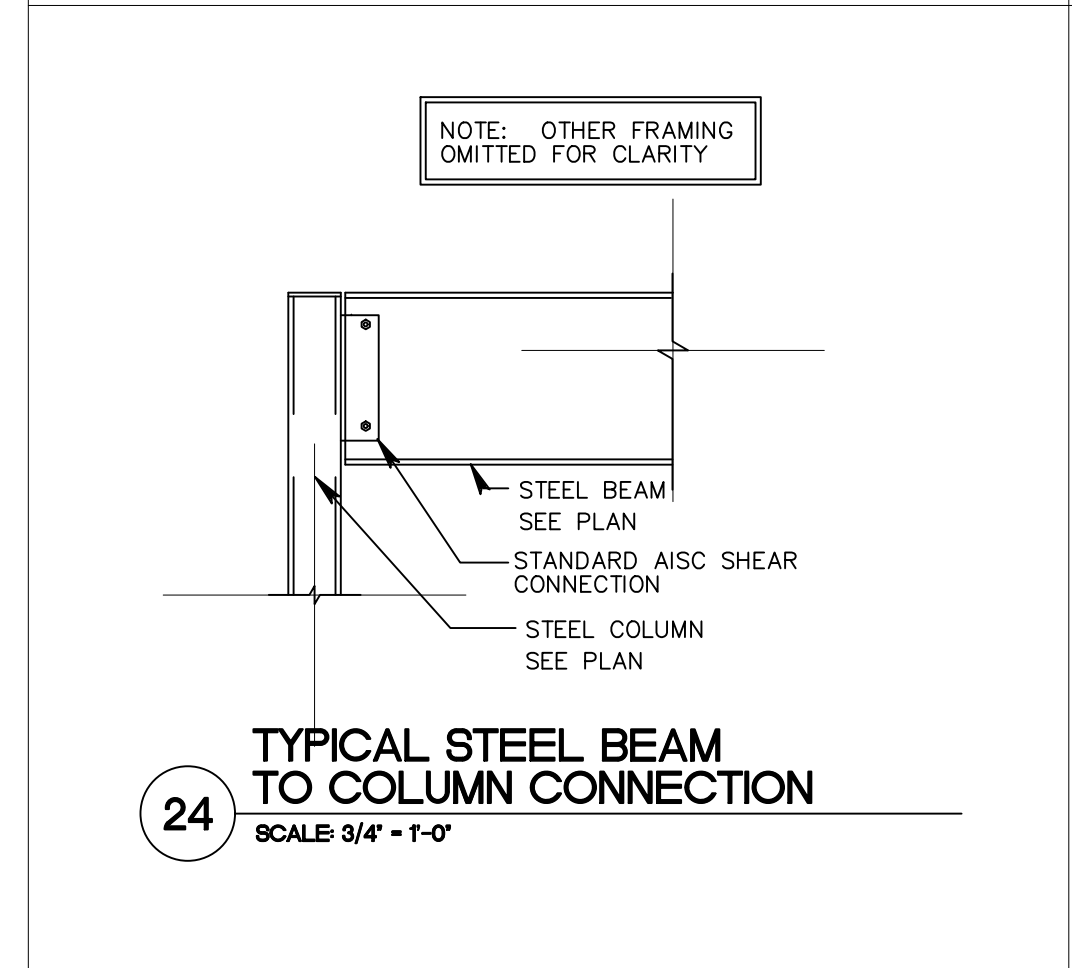
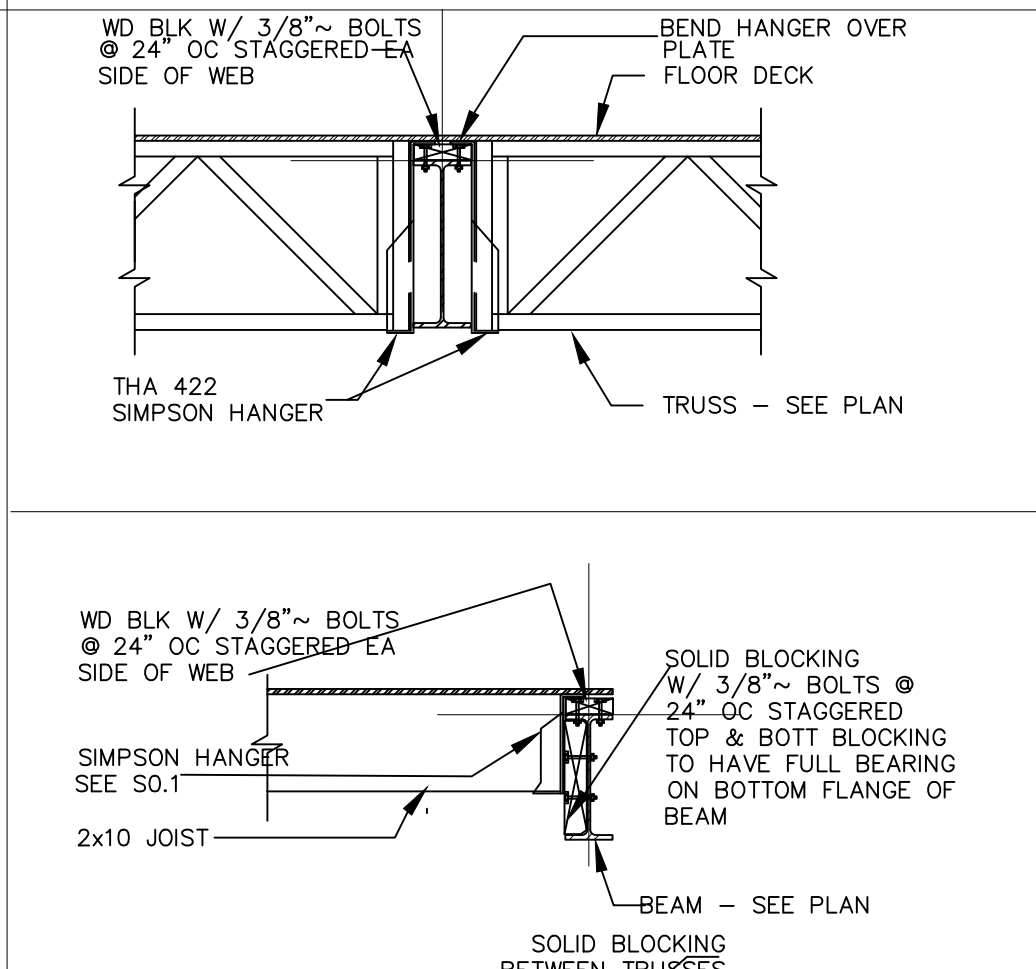
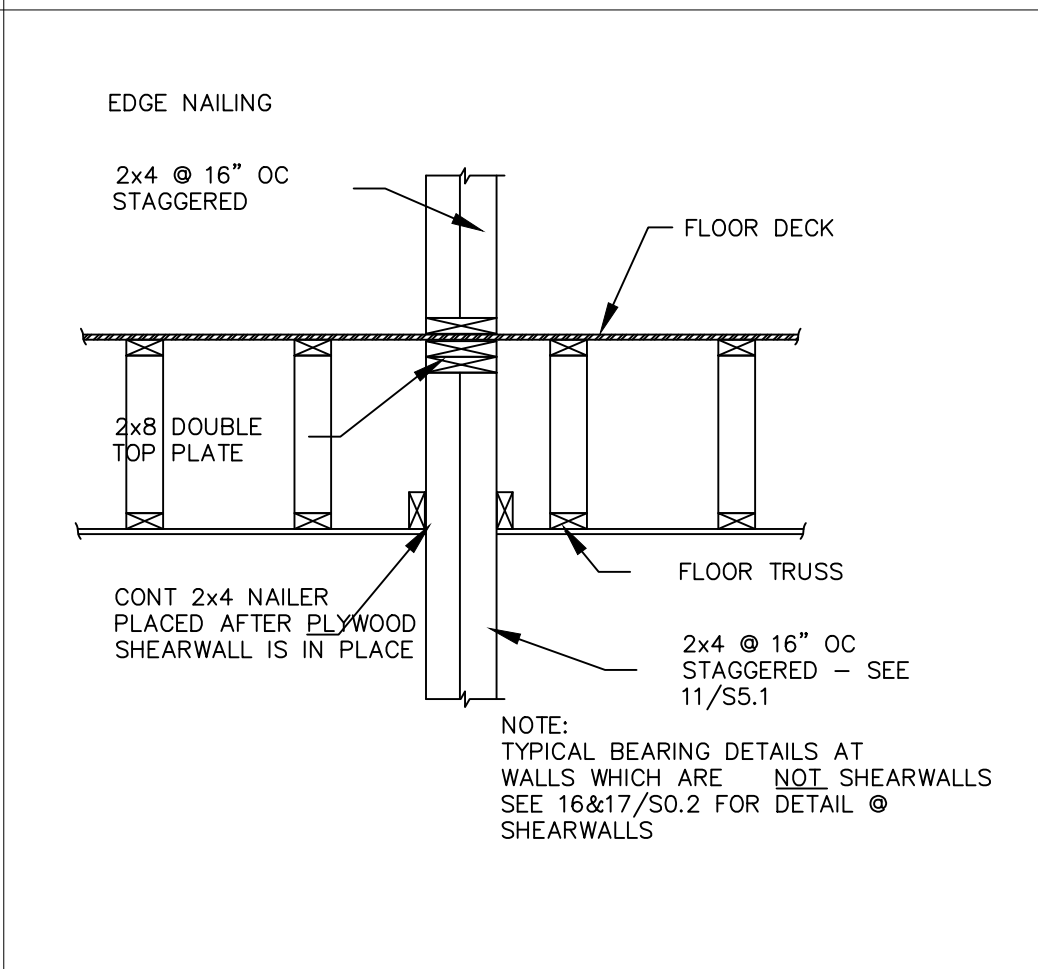
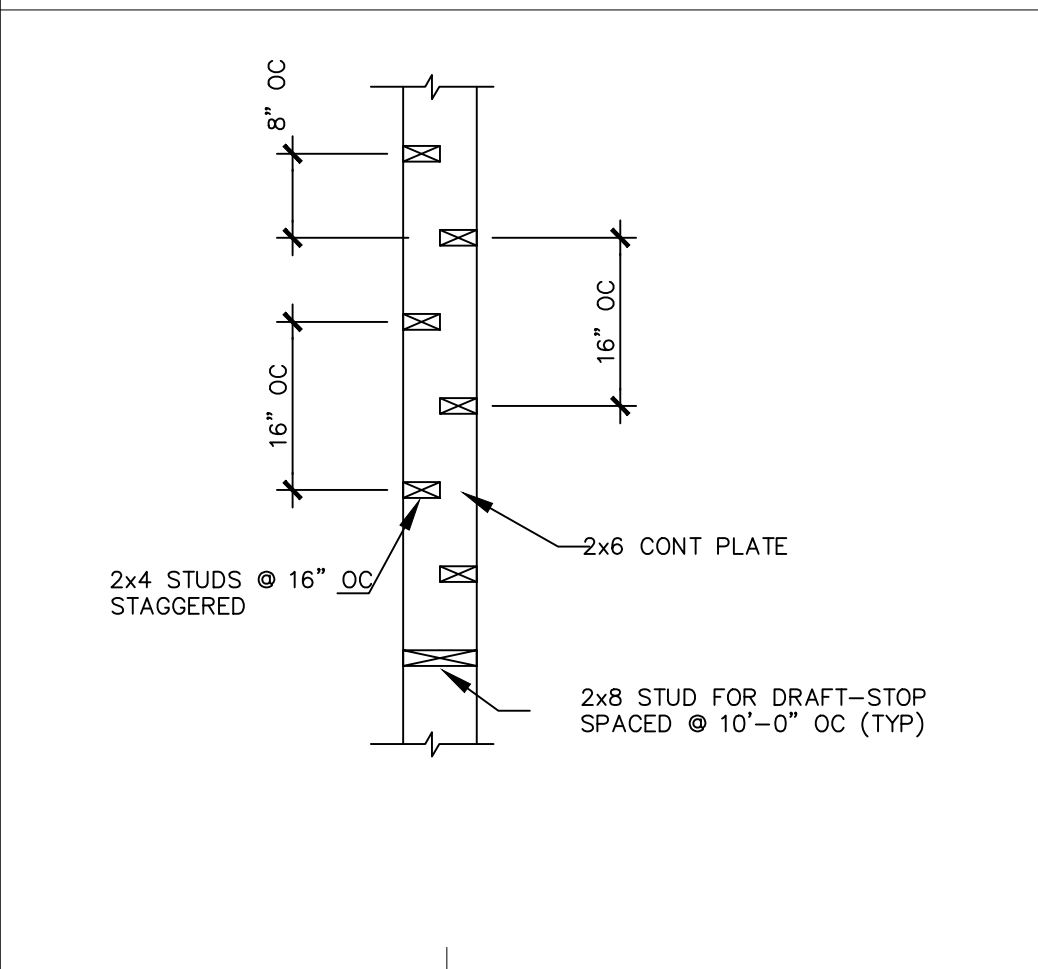
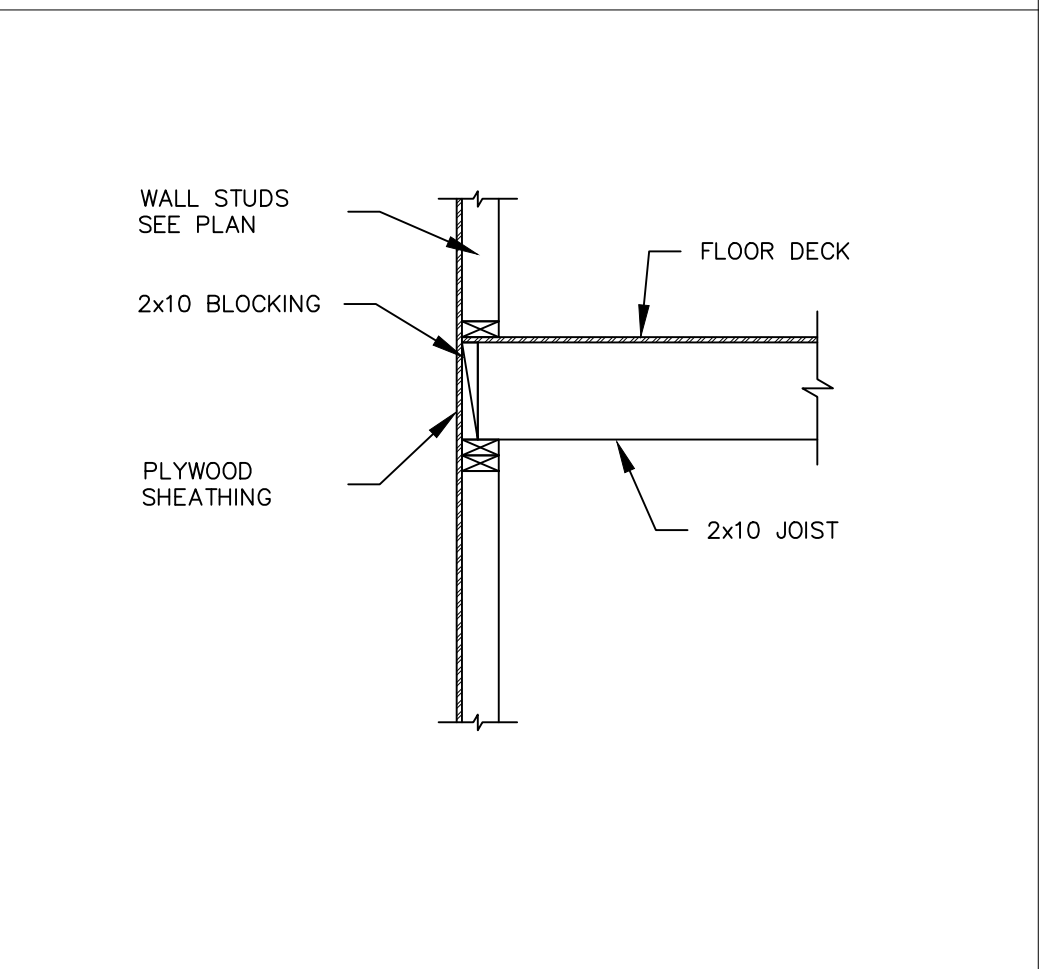
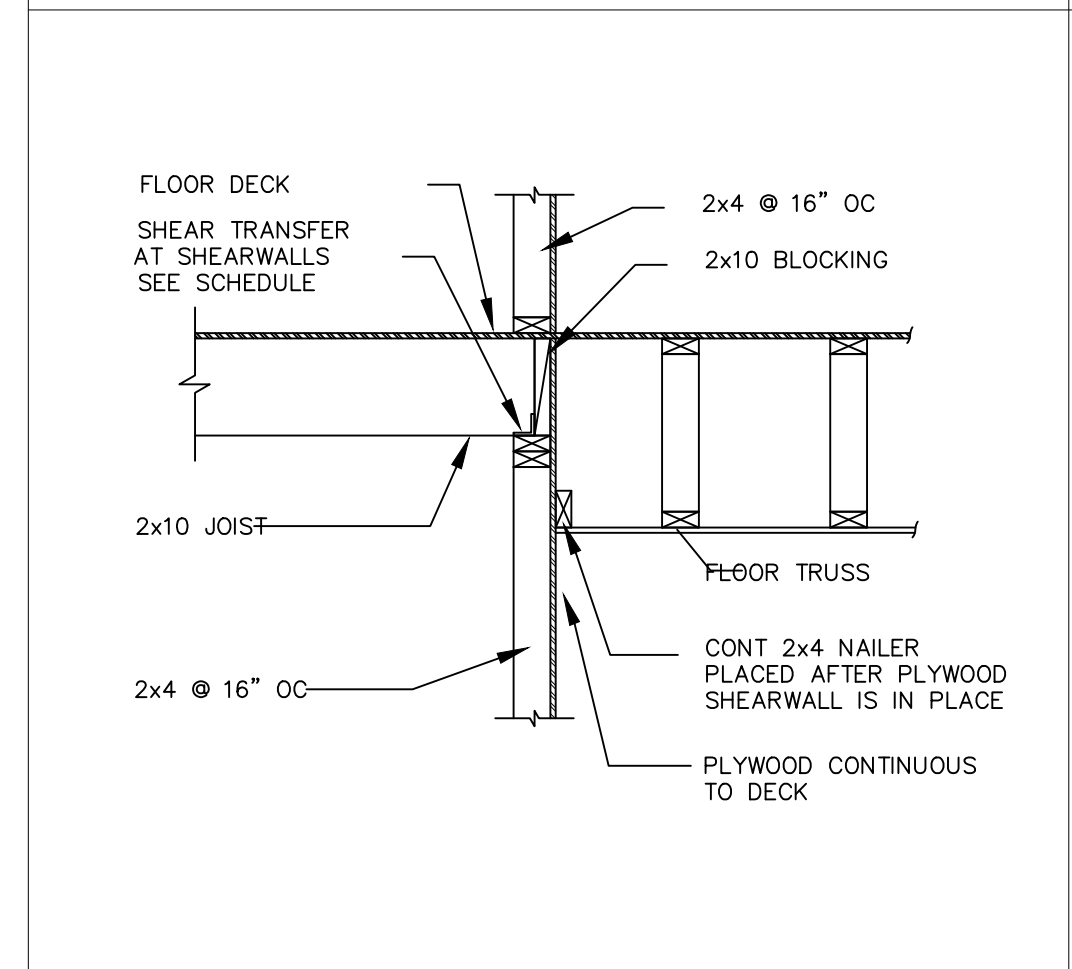
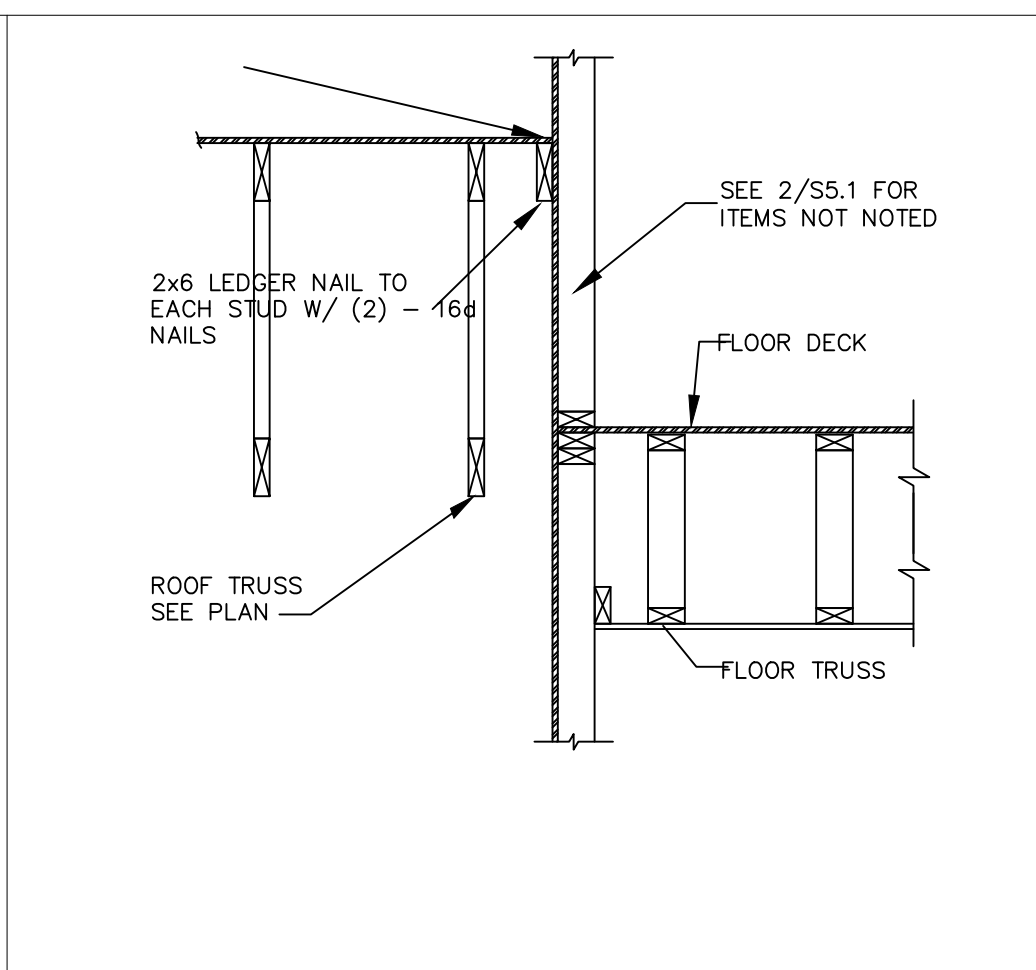
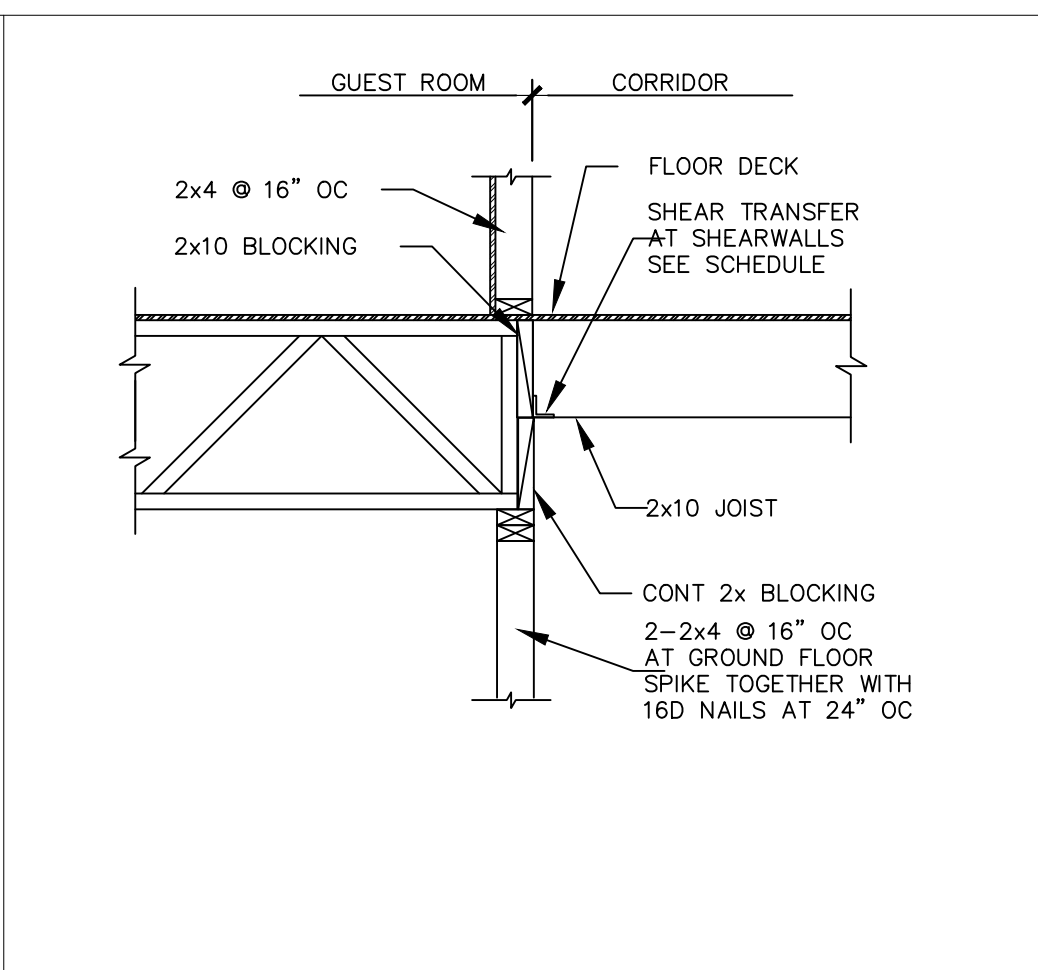
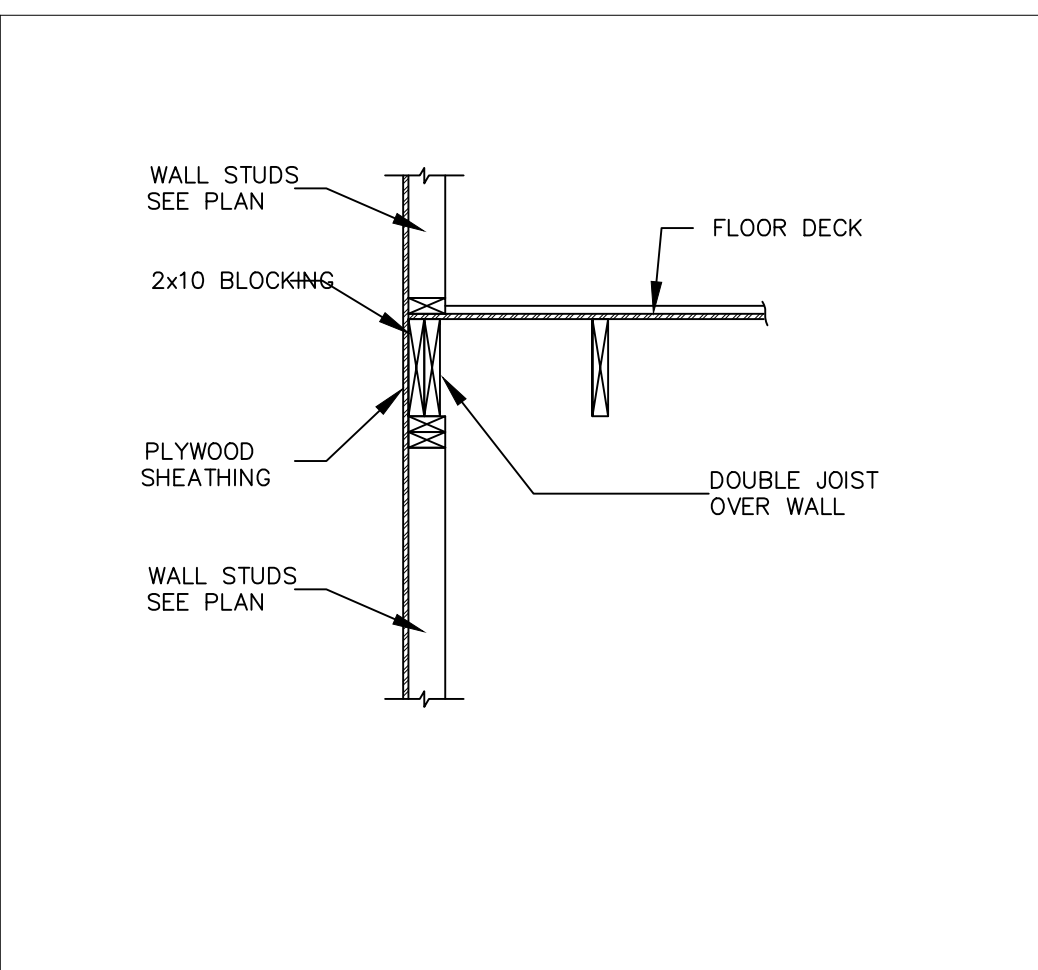
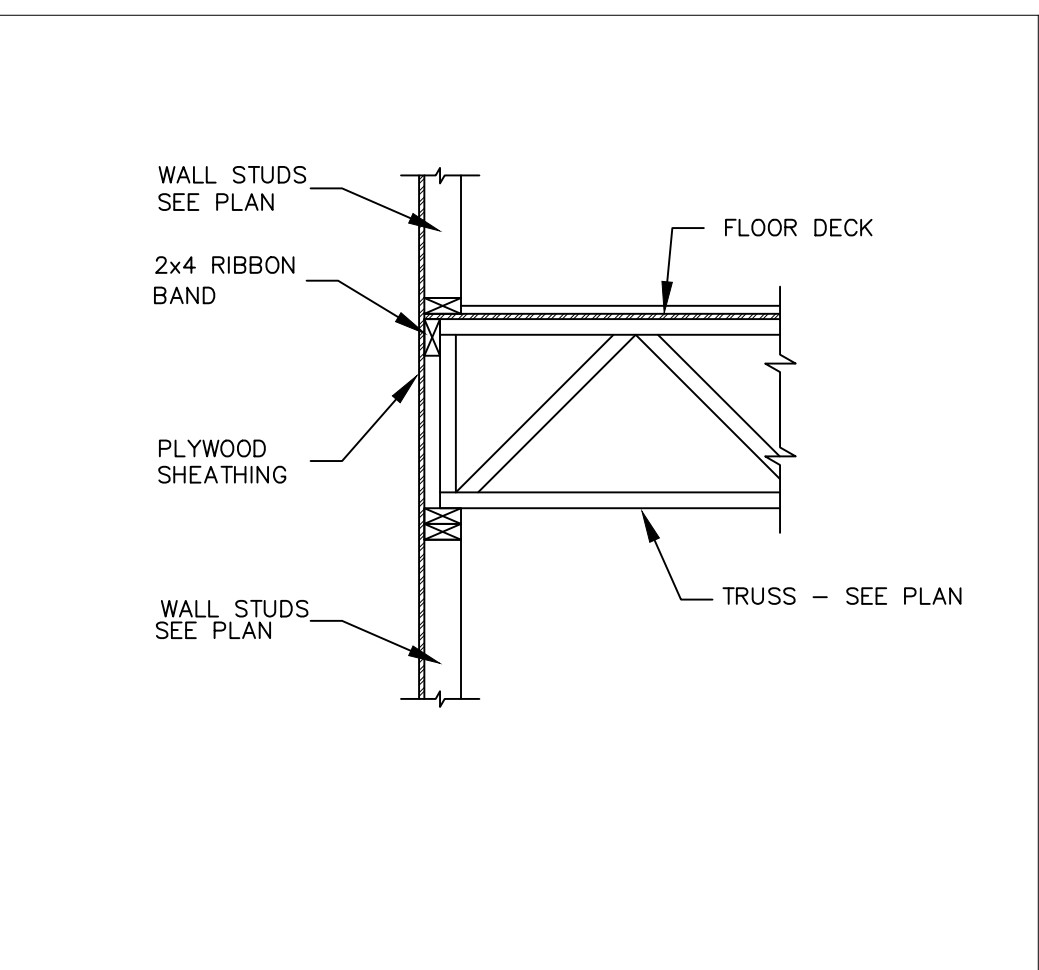
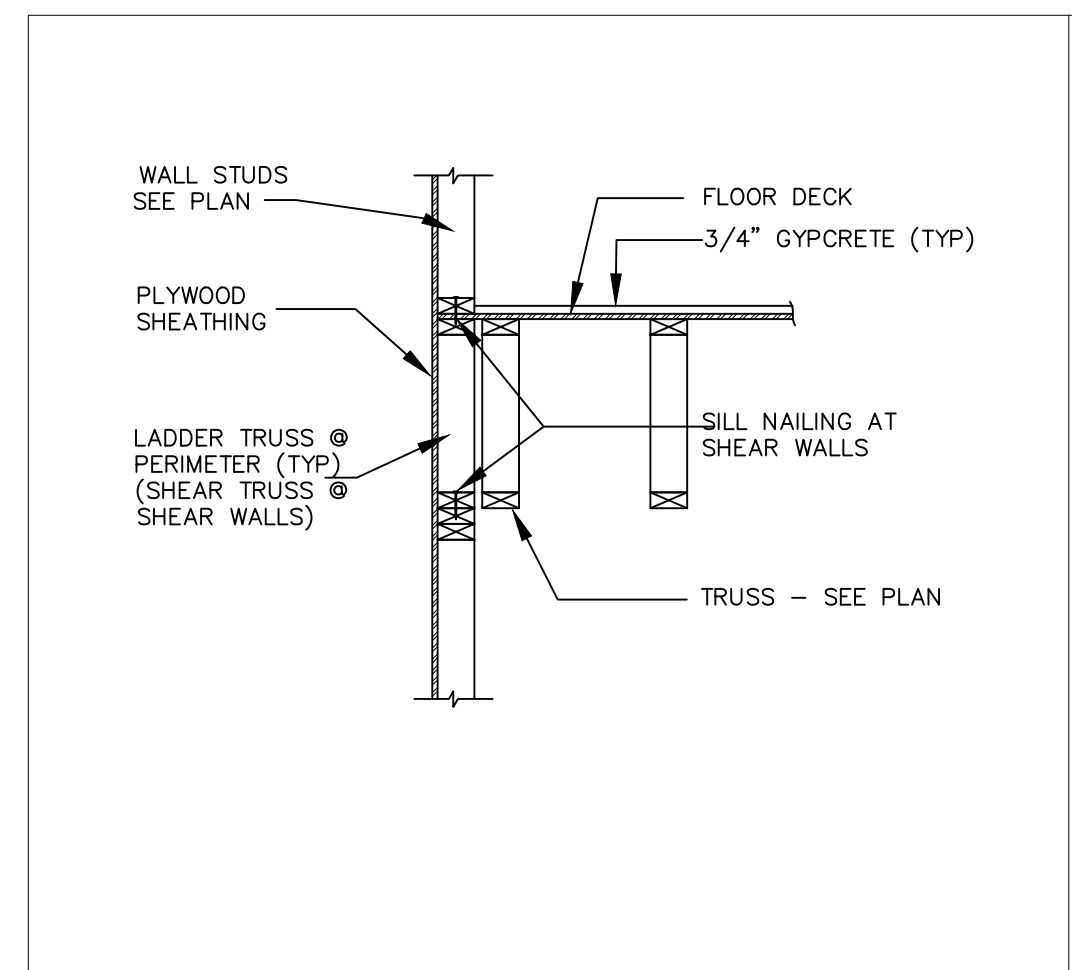

13 TYPICAL NON-LOAD BEARING HEADER
3/4" = 1'-0"

14 TYPICAL LOAD BEARING HEADER
3/4" = 1'-0"

5 TYP. HEADER CONNECTION
N.T.S.

14 TYPICAL RIDGE BRACE DETAIL
SCALE 3/4" = 1'-0"

20 SECTION
SCALE 3/4" = 1'-0"

24 TYPICAL STEEL BEAM TO COLUMN CONNECTION
SCALE 3/4" = 1'-0"

26 MOMENT CONN
SCALE 3/4" = 1'-0"

21 DETAIL AT ELEV BEAM
SCALE 3/4" = 1'-0"

15 TYPICAL EDGE DETAIL
SCALE 3/4" = 1'-0"

16 TYPICAL INTERIOR SHEARWALL PERP TO TRUSS
SCALE 3/4" = 1'-0"