

# HISTORIC AND DESIGN REVIEW COMMISSION

September 20, 2017

**HDRC CASE NO:** 2017-440  
**ADDRESS:** 1226 S PRESA ST  
**LEGAL DESCRIPTION:** NCB 734 BLK 7 LOT 7-8 14, 15, 16, A 19 & A 20  
**ZONING:** IDZ,NCD-1  
**CITY COUNCIL DIST.:** 1  
**APPLICANT:** Mickey Conrad/LPA Inc.  
**OWNER:** Southtown One, Ltd.  
**TYPE OF WORK:** Construction of a townhome development  
**REQUEST:**

The applicant is requesting final approval for the new construction of a townhome development to include 15 townhome units and 5 detached single family homes on the vacant lot addressed 1226 S Presa St. The project is participating in the Center City Housing Incentive Policy (CCHIP).

## APPLICABLE CITATIONS:

*Historic Design Guidelines, Chapter 4, Guidelines for New Construction*

### 1. Building and Entrance Orientation

#### A. FAÇADE ORIENTATION

- i. *Setbacks*—Align front facades of new buildings with front facades of adjacent buildings where a consistent setback has been established along the street frontage. Use the median setback of buildings along the street frontage where a variety of setbacks exist. Refer to UDC Article 3, Division 2. Base Zoning Districts for applicable setback requirements.
- ii. *Orientation*—Orient the front façade of new buildings to be consistent with the predominant orientation of historic buildings along the street frontage.

#### B. ENTRANCES

- i. *Orientation*—Orient primary building entrances, porches, and landings to be consistent with those historically found along the street frontage. Typically, historic building entrances are oriented towards the primary street.

### 2. Building Massing and Form

#### A. SCALE AND MASS

- i. *Similar height and scale*—Design new construction so that its height and overall scale are consistent with nearby historic buildings. In residential districts, the height and scale of new construction should not exceed that of the majority of historic buildings by more than one-story. In commercial districts, building height shall conform to the established pattern. If there is no more than a 50% variation in the scale of buildings on the adjacent block faces, then the height of the new building shall not exceed the tallest building on the adjacent block face by more than 10%.
- ii. *Transitions*—Utilize step-downs in building height, wall-plane offsets, and other variations in building massing to provide a visual transition when the height of new construction exceeds that of adjacent historic buildings by more than one-half story.
- iii. *Foundation and floor heights*—Align foundation and floor-to-floor heights (including porches and balconies) within one foot of floor-to-floor heights on adjacent historic structures.

#### B. ROOF FORM

- i. *Similar roof forms*—Incorporate roof forms—pitch, overhangs, and orientation—that are consistent with those predominantly found on the block. Roof forms on residential building types are typically sloped, while roof forms on non-residential building types are more typically flat and screened by an ornamental parapet wall.

#### C. RELATIONSHIP OF SOLIDS TO VOIDS

- i. *Window and door openings*—Incorporate window and door openings with a similar proportion of wall to window space as typical with nearby historic facades. Windows, doors, porches, entryways, dormers, bays, and pediments shall be considered similar if they are no larger than 25% in size and vary no more than 10% in height to width ratio from adjacent historic facades.
- ii. *Façade configuration*—The primary façade of new commercial buildings should be in keeping with established patterns. Maintaining horizontal elements within adjacent cap, middle, and base precedents will establish a consistent street wall through the alignment of horizontal parts. Avoid blank walls, particularly on elevations visible from the street.

No new façade should exceed 40 linear feet without being penetrated by windows, entryways, or other defined bays.

#### D. LOT COVERAGE

i. *Building to lot ratio*—New construction should be consistent with adjacent historic buildings in terms of the building to lot ratio. Limit the building footprint for new construction to no more than 50 percent of the total lot area, unless adjacent historic buildings establish a precedent with a greater building to lot ratio.

### 3. Materials and Textures

#### A. NEW MATERIALS

i. *Complementary materials*—Use materials that complement the type, color, and texture of materials traditionally found in the district. Materials should not be so dissimilar as to distract from the historic interpretation of the district. For example, corrugated metal siding would not be appropriate for a new structure in a district comprised of homes with wood siding.

ii. *Alternative use of traditional materials*—Consider using traditional materials, such as wood siding, in a new way to provide visual interest in new construction while still ensuring compatibility.

iii. *Roof materials*—Select roof materials that are similar in terms of form, color, and texture to traditionally used in the district.

iv. *Metal roofs*—Construct new metal roofs in a similar fashion as historic metal roofs. Refer to the Guidelines for Alterations and Maintenance section for additional specifications regarding metal roofs.

v. *Imitation or synthetic materials*—Do not use vinyl siding, plastic, or corrugated metal sheeting. Contemporary materials not traditionally used in the district, such as brick or simulated stone veneer and Hardie Board or other fiberboard siding, may be appropriate for new construction in some locations as long as new materials are visually similar to the traditional material in dimension, finish, and texture. EIFS is not recommended as a substitute for actual stucco.

#### B. REUSE OF HISTORIC MATERIALS

*Salvaged materials*—Incorporate salvaged historic materials where possible within the context of the overall design of the new structure.

### 4. Architectural Details

#### A. GENERAL

i. *Historic context*—Design new buildings to reflect their time while respecting the historic context. While new construction should not attempt to mirror or replicate historic features, new structures should not be so dissimilar as to distract from or diminish the historic interpretation of the district.

ii. *Architectural details*—Incorporate architectural details that are in keeping with the predominant architectural style along the block face or within the district when one exists. Details should be simple in design and should complement, but not visually compete with, the character of the adjacent historic structures or other historic structures within the district. Architectural details that are more ornate or elaborate than those found within the district are inappropriate.

iii. *Contemporary interpretations*—Consider integrating contemporary interpretations of traditional designs and details for new construction. Use of contemporary window moldings and door surroundings, for example, can provide visual interest while helping to convey the fact that the structure is new. Modern materials should be implemented in a way that does not distract from the historic structure.

### 5. Garages and Outbuildings

#### A. DESIGN AND CHARACTER

i. *Massing and form*—Design new garages and outbuildings to be visually subordinate to the principal historic structure in terms of their height, massing, and form.

ii. *Building size*—New outbuildings should be no larger in plan than 40 percent of the principal historic structure footprint.

iii. *Character*—Relate new garages and outbuildings to the period of construction of the principal building on the lot through the use of complementary materials and simplified architectural details.

iv. *Windows and doors*—Design window and door openings to be similar to those found on historic garages or outbuildings in the district or on the principal historic structure in terms of their spacing and proportions.

v. *Garage doors*—Incorporate garage doors with similar proportions and materials as those traditionally found in the district.

#### B. SETBACKS AND ORIENTATION

i. *Orientation*—Match the predominant garage orientation found along the block. Do not introduce front-loaded garages or garages attached to the primary structure on blocks where rear or alley-loaded garages were historically used.

ii. *Setbacks*—Follow historic setback pattern of similar structures along the streetscape or district for new garages and

outbuildings. Historic garages and outbuildings are most typically located at the rear of the lot, behind the principal building. In some instances, historic setbacks are not consistent with UDC requirements and a variance may be required.

## 6. Mechanical Equipment and Roof Appurtenances

### A. LOCATION AND SITING

- i. *Visibility*—Do not locate utility boxes, air conditioners, rooftop mechanical equipment, skylights, satellite dishes, and other roof appurtenances on primary facades, front-facing roof slopes, in front yards, or in other locations that are clearly visible from the public right-of-way.
- ii. *Service Areas*—Locate service areas towards the rear of the site to minimize visibility from the public right-of-way.

### B. SCREENING

- i. *Building-mounted equipment*—Paint devices mounted on secondary facades and other exposed hardware, frames, and piping to match the color scheme of the primary structure or screen them with landscaping.
- ii. *Freestanding equipment*—Screen service areas, air conditioning units, and other mechanical equipment from public view using a fence, hedge, or other enclosure.
- iii. *Roof-mounted equipment*—Screen and set back devices mounted on the roof to avoid view from public right-of-way.

## 7. Designing for Energy Efficiency

### A. BUILDING DESIGN

- i. *Energy efficiency*—Design additions and new construction to maximize energy efficiency.
- ii. *Materials*—Utilize green building materials, such as recycled, locally-sourced, and low maintenance materials whenever possible.
- iii. *Building elements*—Incorporate building features that allow for natural environmental control – such as operable windows for cross ventilation.
- iv. *Roof slopes*—Orient roof slopes to maximize solar access for the installation of future solar collectors where compatible with typical roof slopes and orientations found in the surrounding historic district.

### B. SITE DESIGN

- i. *Building orientation*—Orient new buildings and additions with consideration for solar and wind exposure in all seasons to the extent possible within the context of the surrounding district.
- ii. *Solar access*—Avoid or minimize the impact of new construction on solar access for adjoining properties.

### C. SOLAR COLLECTORS

- i. *Location*—Locate solar collectors on side or rear roof pitch of the primary historic structure to the maximum extent feasible to minimize visibility from the public right-of-way while maximizing solar access. Alternatively, locate solar collectors on a garage or outbuilding or consider a ground-mount system where solar access to the primary structure is limited.
- ii. *Mounting (sloped roof surfaces)*—Mount solar collectors flush with the surface of a sloped roof. Select collectors that are similar in color to the roof surface to reduce visibility.
- iii. *Mounting (flat roof surfaces)*—Mount solar collectors flush with the surface of a flat roof to the maximum extent feasible. Where solar access limitations preclude a flush mount, locate panels towards the rear of the roof where visibility from the public right-of-way will be minimized.

### *Unified Development Code Sec. 35-674. - Building Design Principles.*

This section provides policies and standards for the design of commercial, multi-family developments in excess of eight (8) units, and single-family developments in excess of five (5) units or five (5) acres, institutional developments, and industrial buildings within the river improvement overlay districts. In general, principles focus on promoting buildings that will be compatible in scale and appear to "fit" in the community by using materials and forms that are part of the San Antonio design traditions. The policies and standards also promote designs that enhance the streets in the area, as well as the Riverwalk, as places for pedestrians. As such, the policies and guidelines address only broad-scale topics and do not dictate specific design solutions, architectural styles, or details with the exception that the standards for "RIO-3" contain more specific requirements.

(a) Architectural Character. A basic objective for architectural design in the river improvement overlay districts is to encourage the reuse of existing buildings and construction of new, innovative designs that enhance the area, and help to establish distinct identities for each of the zone districts. At the same time, these new buildings should reinforce established building traditions and respect the contexts of neighborhoods.

When a new building is constructed, it shall be designed in a manner that reinforces the basic character-defining features

of the area. Such features include the way in which a building is located on its site, the manner in which it faces the street and its orientation to the river. When these design variables are arranged in a new building to be similar to those seen traditionally, visual compatibility results.

(b) Mass and Scale. A building shall appear to have a "human scale." In general, this scale can be accomplished by using familiar forms and elements interpreted in human dimensions. Exterior wall designs shall help pedestrians establish a sense of scale with relation to each building. Articulating the number of floors in a building can help to establish a building's scale, for example, and prevent larger buildings from dwarfing the pedestrian.

(1) Express facade components in ways that will help to establish building scale.

A. Treatment of architectural facades shall contain a discernable pattern of mass to void, or windows and doors to solid mass. Openings shall appear in a regular pattern, or be clustered to form a cohesive design. Architectural elements such as columns, lintels, sills, canopies, windows and doors should align with other architectural features on the adjacent facades.

(2) Align horizontal building elements with others in the blockface to establish building scale.

A. Align at least one (1) horizontal building element with another horizontal building element on the same block face. It will be considered to be within alignment if it is within three (3) feet, measured vertically, of the existing architectural element.

(3) Express the distinction between upper and lower floors.

A. Develop the first floor as primarily transparent. The building facade facing a major street shall have at least fifty (50) percent of the street level facade area devoted to display windows and/or windows affording some view into the interior areas. Multi-family residential buildings with no retail or office space are exempt from this requirement.

(4) Where a building facade faces the street or river and exceeds the maximum facade length allowed in Table 674-1 divide the facade of building into modules that express traditional dimensions.

A. The maximum length of an individual wall plane that faces a street or the river shall be as shown in Table 674-1.

**Table 674-1**

Description	RIO-1	RIO-2	RIO-3	RIO-4	RIO-5	RIO-6
Maximum Facade Length	50 ft.	50 ft.	30 ft.	75 ft.	75 ft.	50 ft.

B. If a building wall plane facing the street or river and exceeds the length allowed in Table 674-1, employ at least two (2) of the following techniques to reduce the perceived mass:

- Change materials with each building module to reduce its perceived mass; or
- Change the height with each building module of a wall plane. The change in height shall be at least ten (10) percent of the vertical height; or
- Change the roof form of each building module to help express the different modules of the building mass; or
- Change the arrangement of windows and other facade articulation features, such as, columns, pilasters or strap work, which divides large planes into smaller components.

(c)

Height. Building heights vary along the river corridor, from one-story houses to high-rise hotels and apartments. This diversity of building heights is expected to continue. However, within each zone, a general similarity in building heights should be encouraged in order to help establish a sense of visual continuity. In addition, building heights shall be configured such that a comfortable human scale is established along the edges of properties and views to the river and other significant landmarks are provided while allowing the appropriate density for an area.

(1) The maximum building height shall be as defined in Table 674-2.

(2) Organize the mass of the building to step back from established residential neighborhoods. Where a commercial, mixed-use residential, multi-family or industrial use abuts a single-family residential development, or is across the street from a single-family residential development, the following standards shall apply:

The massing of the building shall not exceed twenty-five (25) feet in height at the setback line. The building mass can continue upward within a forty-five-degree building envelope for a distance of fifty (50) feet measured horizontally from the building face, at which point the building massing may continue vertically to the height established in subsection 35-674(c).

(3) On the street-side, the building facade shall appear similar in height to those of other buildings found traditionally in the area.

If fifty (50) percent of the building facades within a block face are predominantly lower than the maximum height allowed, the new building facade on the street-side shall align with the average height of those lower buildings within the block face, or with a particular building that falls within the fifty (50) percent range. However, the remainder of the building may obtain its maximum height by stepping back fifteen (15) feet from the building face.

(4) Designation of a development node provides for the ability to increase the building height by fifty (50) percent from the requirements set out in article VI.

(d) Materials and Finishes. Masonry materials are well established as primary features along the river corridor and their use should be continued. Stucco that is detailed to provide a texture and pattern, which conveys a human scale, is also part of the tradition. In general, materials and finishes that provide a sense of human scale, reduce the perceived mass of a building and appear to blend with the natural setting of the river shall be used, especially on major structures.

(1) Use indigenous materials and traditional building materials for primary wall surfaces. A minimum of seventy-five (75) percent of walls (excluding window fenestrations) shall be composed of the following:

A. Modular masonry materials including brick, stone, and rusticated masonry block, tile, terra-cotta, structural clay tile and cast stone. Concrete masonry units (CMU) are not allowed.

B. Other new materials that convey the texture, scale, and finish similar to traditional building materials.

C. Stucco and painted concrete when detailed to express visual interest and convey a sense of scale.

D. Painted or stained wood in a lap or shingle pattern.

(2) The following materials are not permitted as primary building materials and may be used as a secondary material only:

A. Large expanses of high gloss or shiny metal panels.

B. Mirror glass panels. Glass curtain wall buildings are allowed in RIO-3 as long as the river and street levels comply with 35-674(d)(1) above.

(3) Paint or Finish Colors.

A. Use natural colors of indigenous building materials for properties that abut the Riverwalk area.

B. Use matte finishes instead of high glossy finishes on wall surfaces. Wood trim and metal trim may be painted with gloss enamel.

C. Bright colors may highlight entrances or architectural features.

(e) Facade Composition. Traditionally, many commercial and multi-family buildings in the core of San Antonio have had facade designs that are organized into three (3) distinct segments: First, a "base" exists, which establishes a scale at the street level; second a "mid-section," or shaft is used, which may include several floors. Finally a "cap" finishes the composition. The cap may take the form of an ornamental roof form or decorative molding and may also include the top floors of the building. This organization helps to give a sense of scale to a building and its use should be encouraged.

In order to maintain the sense of scale, buildings should have the same setback as surrounding buildings so as to maintain the street-wall pattern, if clearly established.

In contrast, the traditional treatment of facades along the riverside has been more modest. This treatment is largely a result of the fact that the riverside was a utilitarian edge and was not oriented to the public. Today, even though orienting buildings to the river is a high priority objective, it is appropriate that these river-oriented facades be simpler in character than those facing the street.

(1) Street Facade. Buildings that are taller than the street-wall (sixty (60) feet) shall be articulated at the stop of the street wall or stepped back in order to maintain the rhythm of the street wall. Buildings should be composed to include a base, a middle and a cap.

A. High rise buildings, more than one hundred (100) feet tall, shall terminate with a distinctive top or cap. This can be accomplished by:

- i. Reducing the bulk of the top twenty (20) percent of the building by ten (10) percent.
  - ii. By stepping back the top twenty (20) percent of the building.
  - iii. Changing the material of the cap.
- B. Roof forms shall be used to conceal all mechanical equipment and to add architectural interest to the structure.
  - C. Roof surfaces should include strategies to reduce heat island effects such as use of green roofs, photo voltaic panels, and/or the use of roof materials with high solar reflectivity.
- (2) Fenestration. Windows help provide a human scale and so shall be proportioned accordingly.
- A. Windows shall be recessed at least two (2) inches within solid walls (not part of a curtain wall system).
  - B. Windows should relate in design and scale to the spaces behind them.
  - C. Windows shall be used in hierarchy to articulate important places on the facade and grouped to establish rhythms.
  - D. Curtain wall systems shall be designed with modulating features such as projecting horizontal and/or vertical mullions.
- (3) Entrances. Entrances shall be easy to find, be a special feature of the building, and be appropriately scaled.
- A. Entrances shall be the most prominent on the street side and less prominent on the river side.
  - B. Entrances shall be placed so as to be highly visible.
  - C. The scale of the entrance is determined by the prominence of the function and or the amount of use.
  - D. Entrances shall have a change in material and/or wall plane.
  - E. Entrances should not use excessive storefront systems.

## **FINDINGS:**

- a. The applicant has proposed to construct 15 townhome units and 5 detached, 2-story single family homes on the vacant lot located at 1226 S Presa St. The lot is located within Neighborhood Conservation District 1 (NCD-1) and is not zoned historic or located within a River Improvement Overlay (RIO) district. The project is participating in the Center City Housing Incentive Policy (CCHIP), which requires review and approval by the Historic and Design Review Commission as part of a project's eligibility. The Office of Historic Preservation and the HDRC are charged with reviewing the proposal for basic consistency and appropriateness relative to the established development pattern and existing context in the vicinity of the project utilizing design guidelines, including the Historic Design Guidelines and River Improvement Overlay building design principles in the Unified Development Code.
- b. The applicant met with the Design Review Committee (DRC) on July 25, 2017. The DRC commended the applicant for addressing the corner units as true corner conditions and scaling the development appropriately for the context. Suggestions included the following: provide exhibits where the units meet the neighboring properties to give a sense of context and understanding of a 3-story height unit directly abutting a 1-story historic home; address the Vance elevations as their own unique address, and define their entrances at the pedestrian level, particularly the way the porch reads as an entrance; consider transitions and visibility, porch barriers, views of the complex from neighbors and vice versa; consider breaking up the continuity of the facades by introducing slight material or color variations; consider the impact of a 3-story board and batten condition on the Vance elevations; study historic door patterns and select windows that are proportionate to neighborhood context. Overall, the proposal was well received and commended for its handling of rooftop mechanical equipment, scale, form, and contextual considerations.
- c. **SETBACKS & ORIENTATION** – According to the Guidelines for New Construction, the front facades of new buildings are to align with front facades of adjacent buildings where a consistent setback has been established along the street frontage. Additionally, the orientation of new construction should be consistent with the historic examples found on the block. Per the applicant's proposed site plan, the setbacks match the adjacent existing historic homes. Staff finds the proposal consistent with the Guidelines.
- d. **SCALE & MASS** – The applicant has proposed to construct a townhome development consisting of both attached and detached units with two-and-a-half to three stories. The height of the units range from approximately 34 feet to approximately 37 feet at the maximum roof ridgelines. Per the Guidelines for New Construction 2.A.i., a height and massing similar to historic structures in the vicinity of the proposed new construction should be used. In residential districts, the height and scale of new construction should not exceed that of the majority of historic buildings by more than one-story. The property located adjacent to the edge of the Lavaca Historic District and is surrounded by 1-story and 2-story historic single family homes to the north and west, larger 2-story multifamily homes to the east, and 1-story and 2-story historic homes to the south, as well as commercial blocks exceeding 2 stories in height. However, the proposal directly abuts a 1-story historic single family home on S Presa St and on Vance St. The elevations at these meeting points are scaled appropriately to meet the existing structure, including

a massing step-down and front setback at the S Presa edge. Staff finds the scale appropriate.

- e. **FOUNDATION & FLOOR HEIGHTS** – According to the Guidelines for New Construction 2.A.iii., foundation and floor height should be aligned within one (1) foot of neighboring structure’s foundation and floor heights. Neighboring historic structures feature foundation heights of approximately two to three feet. The applicant has proposed slab on grade foundations with a height less than one foot. However, the previous structures located on the site were commercial in nature and featured little to no foundation. Staff finds the proposal acceptable based on these considerations.
- f. **ENTRANCES** – Per the Guidelines for New Construction 1.B.i., primary building entrances should be oriented towards the primary street. The applicant has proposed to orient the primary entrances of the attached townhomes towards their respective primary streets of S Presa St and Florida St. The detached townhomes on Vance St are oriented towards an interior driveway, which is a departure from the traditional residential development of the Lavaca Historic District. However, these units feature prominent front porches that emulate the historic porch conditions of the district, and help define the pedestrian entrances along the streetscape. Staff finds the proposal consistent with the Guidelines.
- g. **PORCHES** – Architectural details, such as well-proportioned porch elements, window coverings, roof eaves, and variations in wall planes add depth and visual interest and contribute to the overall quality of the design. The applicant has integrated 2-story porches with shed roofs on all facades of the development. The porches are uncovered on the first floor and screened on the second floor. They project towards the streetscape and are pedestrian in scale. Additionally, the applicant has selected four paint colors – charcoal, sage, slate, and wine – to add visual differentiation and diversity to the otherwise consistent form of the porches. Staff finds the proposal consistent with the Guidelines and appropriate for the site context.
- h. **WALL PLANE ARTICULATION** – The proposal features long facades with repeated jointed units. The façade on Florida St features eight consecutive units measuring three stories in height. The façade of these jointed units will be clad in board and batten siding from grade to roof level. According to the RIO guidelines in UDC Section 35-674, if a wall plane exceeds 50 square feet, two of the four following approaches should be employed: change in materials with each module to reduce mass; change in the height of each module; change of roof form of each module to help express different modules of the building mass; or change the arrangement of windows and other façade articulation features to divide a plane in to smaller components. The applicant has employed the technique of modifying the arrangement of the front porches, as well as installing downspouts at the joints, but the continuity of the wall plane between units, coupled with three story board and batten siding, minimizes the relationship with the pedestrian scale. The applicant should explore ways to demarcate the walls between units to better establish this relationship, either with a vertical trim piece, slight shift in wall plane for depth, exploration of color, or different method.
- i. **ROOF FORM** – The proposed development integrates traditional gable roof forms with porches with shed roofs. Gable roofs and porches with shed roofs are common on historic residential structures in the vicinity. Staff finds the proposal consistent with the Guidelines.
- j. **MATERIALITY** – The proposed development includes vertical board and batten siding that features a smooth finish, an exposure of four inches, and boards that are 12 inches wide with battens that are 1-1/2” wide; fiber cement siding with the smooth side exposed; painted wood porches; a standing seam metal roof that features panels that are 18 to 21 inches wide, seams that are 1 to 2 inches in height, a crimped ridge seam or low profile ridge cap, and a standard galvalume finish; wood trellises; and galvanized welded wire fencing. The materials are consistent and appropriate.
- k. **WINDOW & DOOR OPENINGS: PROPORTIONS** – Per the Guidelines for New Construction 2.C.i. window and door openings with similar proportions of wall to window space as typical with nearby historic facades should be incorporated into new construction. Staff finds the proposed sizes acceptable.
- l. **WINDOW & DOOR OPENINGS: MATERIALITY** – According to the Historic Design Guidelines for Windows, windows used in new construction should maintain traditional dimensions and profiles, be recessed within the window frame, feature traditional materials or appearance, and feature traditional trim and sill details. The applicant has proposed Pella fiberglass windows and doors in the color black. Staff finds the proposal acceptable with the stipulations listed in the recommendation.
- m. **ARCHITECTURAL DETAILS** – According to the Historic Design Guidelines for New Construction, architectural details that are in keeping with the predominant architectural style along the block face or within the district should be implemented. Details should be simple in design and should complement, but not visually compete with, the character of the adjacent historic structures or other historic structures within the district. Staff finds the proposal generally consistent with the Guidelines.
- n. **MECHANICAL EQUIPMENT & SCREENING** – Per the Guidelines for New Construction 6., all mechanical

equipment should be screened from view at the public right of way. The applicant has proposed recessed roof channels to conceal rooftop mechanical equipment from view. This approach also minimizes the overall roof height, as it eliminates the need to integrate mechanical equipment in an interior space. The applicant has also proposed a vertical wood screen trash enclosure at the intersection of S Presa St and Florida St. Staff finds the proposal generally consistent with the Guidelines.

- o. **PARKING** – The applicant has noted that each structure is to have designated parking, either in the form of a covered carport or in the form of an attached garage, oriented towards the interior of the lot. Staff finds the proposal appropriate.
- p. **LANDSCAPING** – The applicant has developed a landscaping plan to include several native and drought-resistant plants. The trees facing the primary streets include Red Oak, Red Bud, Cedar Elm, and Lacey Oak. Additional plantings include Yaupon Holly, Monterrey Oak, Anacacho Orchid, Passumhaw Holly, Cimarron Texas Ranger, Butterfly Iris, Upright Rosemary, Seabreeze Bamboo, Mexican Feather Grass, Flamenco Red Yucca, Flame Acanthus, Turks Cap, Pink Mulhy Grass, and Star Jasmine. Staff finds the proposal consistent with the Guidelines.

### **RECOMMENDATION:**

Staff recommends approval based on findings a through p with the following stipulations:

- i. The applicant explores ways to demarcate the walls between joined units to better address the human scale, either by adding a vertical trim piece, slight shift in wall plane for depth, application of color, or different method to these units, as noted in finding h.
- ii. That the applicant installs windows that feature meeting rails no taller than 1.25” and stiles no wider than 2.25”. There should be a minimum of two inches in depth between the front face of the window trim and the front face of the top window sash. This must be accomplished by recessing the window sufficiently within the opening or with the installation of additional window trim to add thickness. Window trim must feature traditional dimensions and architecturally appropriate sill detail.

### **CASE MANAGER:**

Stephanie Phillips

### **CASE COMMENTS:**

The applicant met with the Design Review Committee (DRC) on July 25, 2017. The discussion is outlined in finding b.





## Flex Viewer

Powered by ArcGIS Server

Printed: Aug 25, 2017

The City of San Antonio does not guarantee the accuracy, adequacy, completeness or usefulness of any information. The City does not warrant the completeness, timeliness, or positional, thematic, and attribute accuracy of the GIS data. The GIS data, cartographic products, and associated applications are not legal representations of the depicted data. Information shown on these maps is derived from public records that are constantly undergoing revision. Under no circumstances should GIS-derived products be used for final design purposes. The City provides this information on an "as is" basis without warranty of any kind, express or implied, including but not limited to warranties of merchantability or fitness for a particular purpose, and assumes no responsibility for anyone's use of the information.



AAA Freight Salvage Sales

Vale Law Firm

1226 South Presa Street

Florida Park

Saint Anthony The Great Orthodox Church-Oca

Clay's Auto



## PROJECT NARRATIVE

Date: August 11, 2017

To: Historic Design Review Commission  
Office of Historic Preservation  
1901 S. Alamo St.  
San Antonio, TX 78204

From: LPA, Inc.

Project Name: 1226 S. Presa

Regarding: Application for certificate of appropriateness

### Project Narrative

The project proposes the construction of 15 townhome units, and 5 detached single family homes on the parcel located at 1226 S. Presa St. The design of the project incorporates traditional gable roof forms, screen porches, and a shared materiality to the existing neighborhood. Multiple front porch designs were developed to reflect the diversity of the neighborhood and provide each with individual architectural identity.

The siting of the project establishes an urban street frontage along Florida St, while respecting the existing street set back on S. Presa and Vance St. This site organization, along with an approved variance for 3 story townhomes, allows for attached garages in all units oriented away from the surrounding streets. Balconies, screened and open porches facing the streets provide a pedestrian scale. The rhythm of the porch pattern and color, gabled forms, trim and downspouts all contribute to the articulation of the individual living units and articulate the building wall plane.

Traditional standing seam metal with 18" wide panels and crimped 1.5" seams on gabled roofs and wood siding, common to the area, are used to blend the project into the character of the neighborhood. The gable roofs reference the traditional roof forms, while the parapet allows for an area to store mechanical equipment on the roof out of view. 12" wide board and 1x2 vertical batten siding will provide a familiar wall texture. Window proportions and surrounding trim are like what is found in the neighborhood.

After meeting with staff and members of the Historic Design Review Commission on July 25th, their suggestions were addressed by enhancing the homes individual identities through color variation, which was applied to the screen porches. Changes were also made to the scale and articulation on the units facing Vance St. to address a more defined entry. Several windows were eliminated to address concerns of privacy for the neighbors on the west property line. Awning elements were also incorporated on the west units to increase articulation on the wall facing S. Presa and provide a pedestrian scale and shading for the remaining windows.

The unit at the northwest corner of the project and adjacent to a one story historic home will feature a stepped down two-story element and be set back a few feet behind to allow a transition from the project to the neighboring context.

The historic home and 9,300 square foot parcel on the corner of Vance and Labor, is not included in this application. A future proposal will address the historic home on the corner of Vance St. and Labor St. This future proposal tentatively includes relocating the historic home to a more prominent location on the corner of Vance and Labor street.

#### Project Description

Requesting Certificate of Appropriateness to:

Unit Type A - Construct one, 2,653 square foot townhouse units with attached two car garages. Materials are to include vertical board and batten siding, painted wood porches, a standing seam metal roof, wood trellis, and galvanized welded wire fencing.

Unit Type B1 - Construct seven, 2,400 square foot townhouse units with attached two car garages. Materials are to include vertical board and batten siding, painted wood porches, a standing seam metal roof, wood trellis, and galvanized welded wire fencing.

Unit Type B2 - Construct five, 2,295 square foot townhouse units with attached two car garages. Materials are to include vertical board and batten siding, painted wood porches, a standing seam metal roof, wood trellis, and galvanized welded wire fencing.

Unit Type C Detached - Construct four, 2,111 square foot single family homes with attached two car garages. Materials are to include vertical board and batten siding, painted wood porches, a standing seam metal roof, wood trellis, and galvanized welded wire fencing.

Unit Type D Detached home- Construct one, 1,936 square foot single family home with attached single car garage. Materials are to include vertical board and batten siding, painted wood porches, a standing seam metal roof, wood trellis, and galvanized welded wire fencing.

Unit Type D Townhome - Construct two, 1,936 square foot townhomes with attached single car garage. Materials are to include vertical board and batten siding, painted wood porches, a standing seam metal roof, wood trellis, and galvanized welded wire fencing

**1226 S. PRESA**

TABLE OF CONTENTS

**OVERALL**

PROJECT OVERVIEW	2
EXISTING CONDITIONS	3
PREVIOUS CONTEXT	4
SITE PLAN	5
BLOCK SETBACK DIAGRAM	6

**ARCHITECTURAL**

PERSPECTIVE   FLORIDA + LABOR	7
PERSPECTIVE   FLORIDA + S. PRESA	8
PERSPECTIVE   S. PRESA	9
PERSPECTIVE   VANCE ST.	10
STREET ELEVATIONS	11
MATERIALS AND DETAILS	13

**LANDSCAPE**

LANDSCAPE PLAN	18
LANDSCAPE SELECTIONS	19

**UNIT PLANS**

UNIT SITE PLAN	21
UNIT A	22
UNIT B1	23
UNIT B1 SECTION	24
UNIT B2	25
UNIT B2 SECTION	26
UNIT C	27
UNIT D	28
UNIT C AND D SECTIONS	29

# 1226 S. PRESA



# EXISTING SITE PHOTOGRAPHS



CORNER OF FLORIDA ST. AND LABOR ST.



S. PRESA LOOKING SOUTH



VANCE ST.



S. PRESA LOOKING NORTH

# PRIOR CONTEXT PHOTOGRAPHS



S. PRESA ST



VANCE ST.



# SITE PLAN



1/64" = 1'-0"



p. 210.829.1737  
w. lpainc.com

f. 210.829.1730  
e. lpa@lpainc.com

114 East Cevallos Street,  
San Antonio, Texas 78204

# LOT SET BACK EXHIBIT

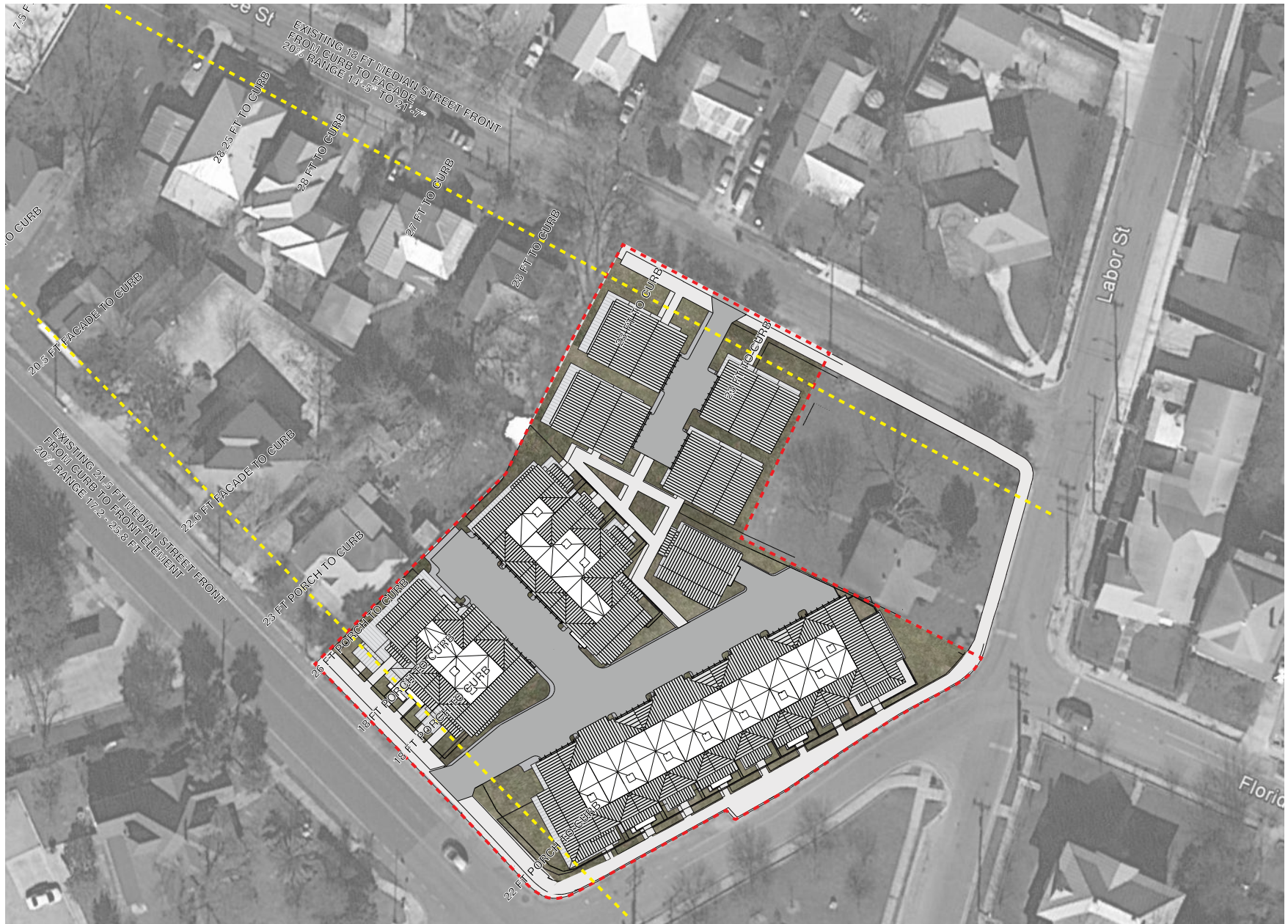

1/64" = 1'-0"

09.11.2017 | 1226 S. Presa



**EXTERIOR VIEWS** | FLORIDA ST. / LABOR ST.



**EXTERIOR VIEWS** | VANCE ST.



**EXTERIOR VIEWS** | S. PRESA ST.



# STREET ELEVATIONS



FLORIDA ST. ELEVATION



S. PRESA ST. DRIVEWAY SOUTH ELEVATION



S. PRESA ST. ELEVATION

3/64" = 1'-0"

# STREET ELEVATIONS



COURTYARD TOWNHOMES ELEVATION



COURTYARD TOWNHOMES REAR



VANCE ST. ELEVATION

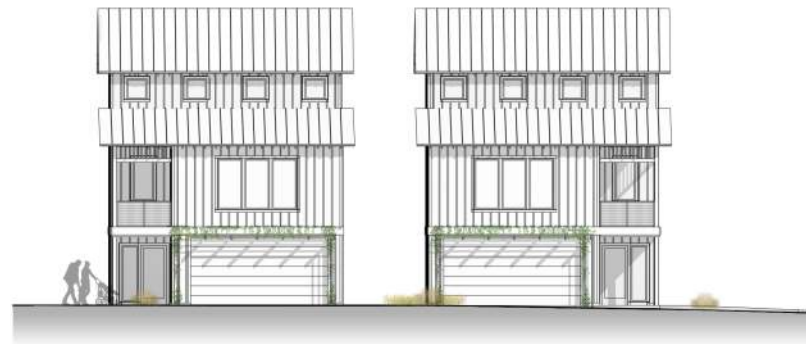

VANCE ST. DRIVEWAY ELEVATION

1/16" = 1'-0"



# EXTERIOR VEIWS | TOWNHOUSE UNITS

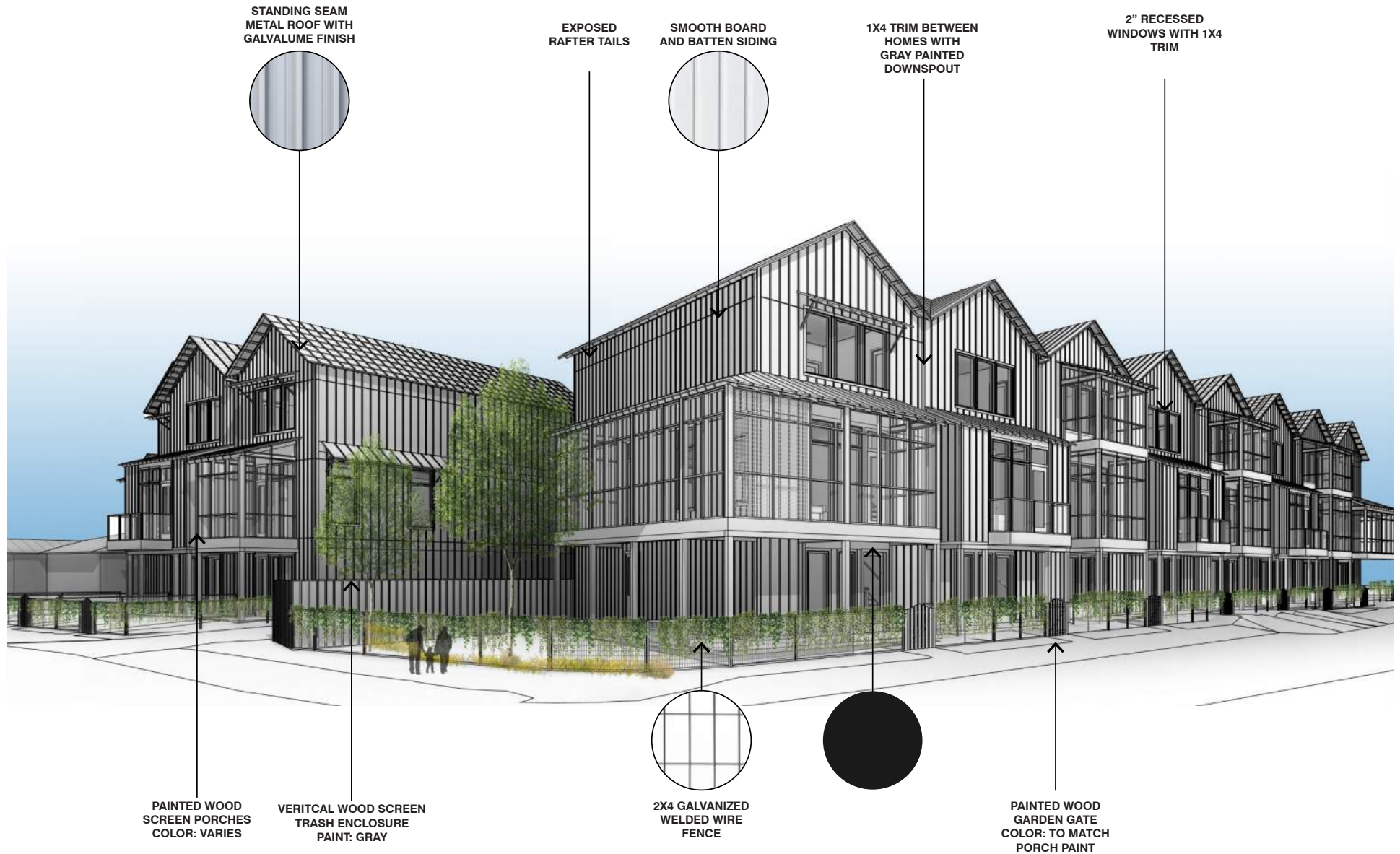

# EXTERIOR VEIWS | DETACHED UNITS



# EXTERIOR VIEWS



# MATERIALS

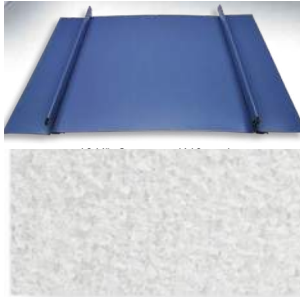

18" PANEL STANDING SEAM  
METAL ROOF WITH 1.5" SEAMS  
COLOR: NATURAL GALVALUME



SMOOTH BOARD AND  
BATTEN SIDING 12" PANEL  
WITH 1X2 BATTENS  
COLOR: ARCTIC WHITE

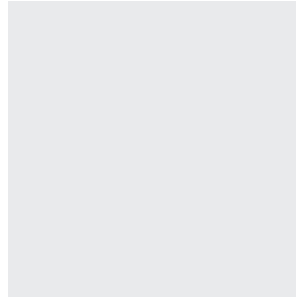

PAINTED WOOD  
EXPOSED RAFTER TAILS  
COLOR: ARCTIC WHITE

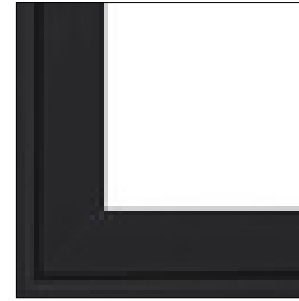

PELLA FIBERGLASS  
WINDOWS AND DOORS  
COLOR: BLACK



FIBER CEMENT  
PANEL SIDING  
COLOR: IRON GRAY



PAINTED WOOD PORCHES  
AND GARDEN GATE  
COLOR: CHARCOAL



PAINTED WOOD PICKET  
GARDEN GATE  
COLOR: SAGE

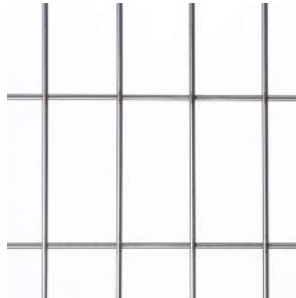

2" X 4" GALVANIZED  
WELDED WIRE  
FENCE



FRONT DOOR OPTION 1



FRONT DOOR OPTION 2

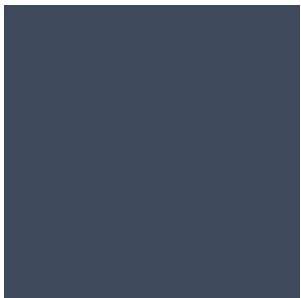

PAINTED WOOD PORCHES  
AND GARDEN GATE  
COLOR: SLATE



PAINTED WOOD PICKET  
GARDEN GATE  
COLOR: WINE

# DETAILS

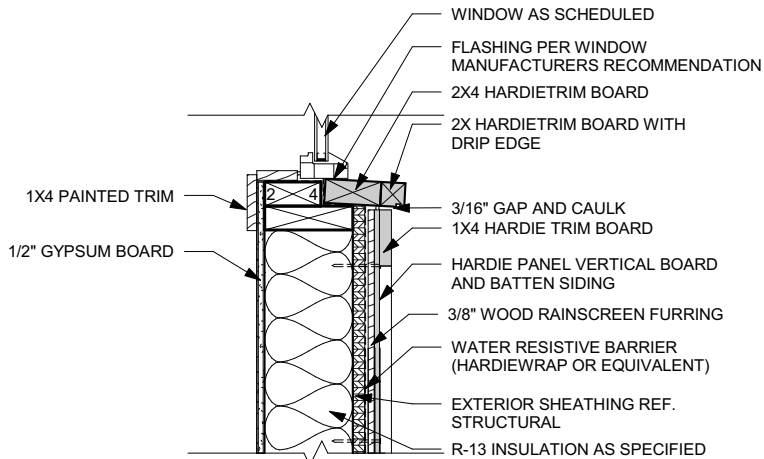
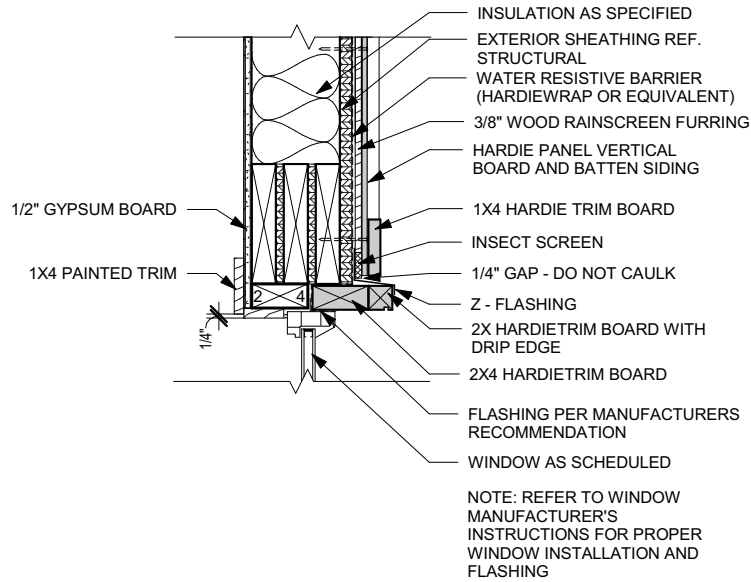

TYP. INSET WINDOW DETAIL  
 WITH 1X4 TRIM  
 1" = 1'-0"

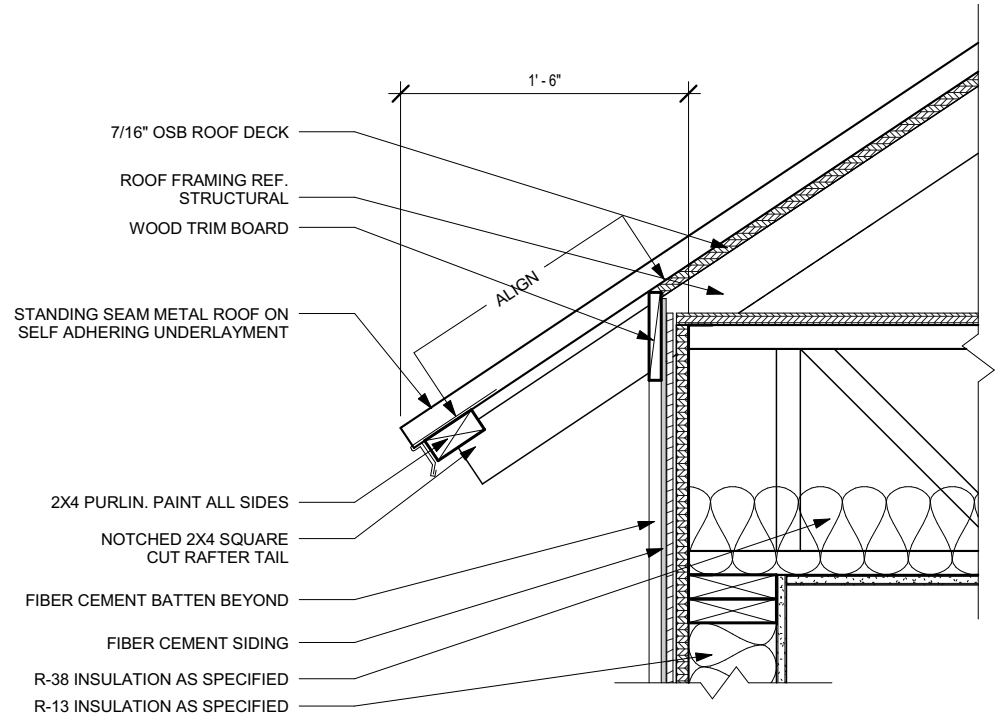

TYP. EAVE DETAIL  
 1" = 1'-0"

# LANDSCAPE PLAN



1" = 40'-0"

# TREE SELECTIONS



Cedar Elm



Texas Red Oak



Redbud



Yaupon Holly



Monterrey Oak



Lacey Oak



Anacacho Orchid



Possumhaw Holly

# PLANTING SELECTIONS



Cimarron Texas Ranger



Cimarron Texas Ranger



Upright Rosemary



Seabreeze Bamboo



Mexican Feather Grass



Flamenco Red Yucca



Flame Acanthus



Turks Cap



Pink Muhly Grass



Star Jasmine



# SITE PLAN



NOT TO SCALE



**UNIT A** | 2,241 SF

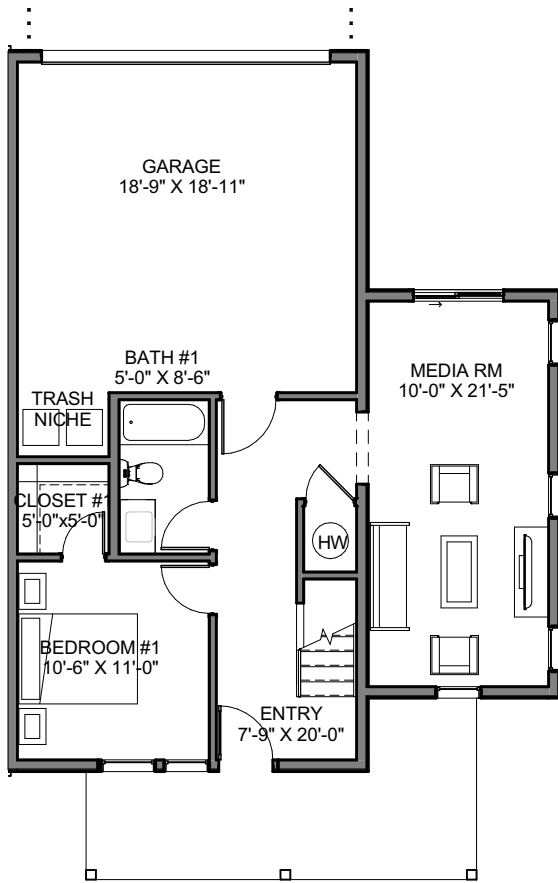

FIRST FLOOR

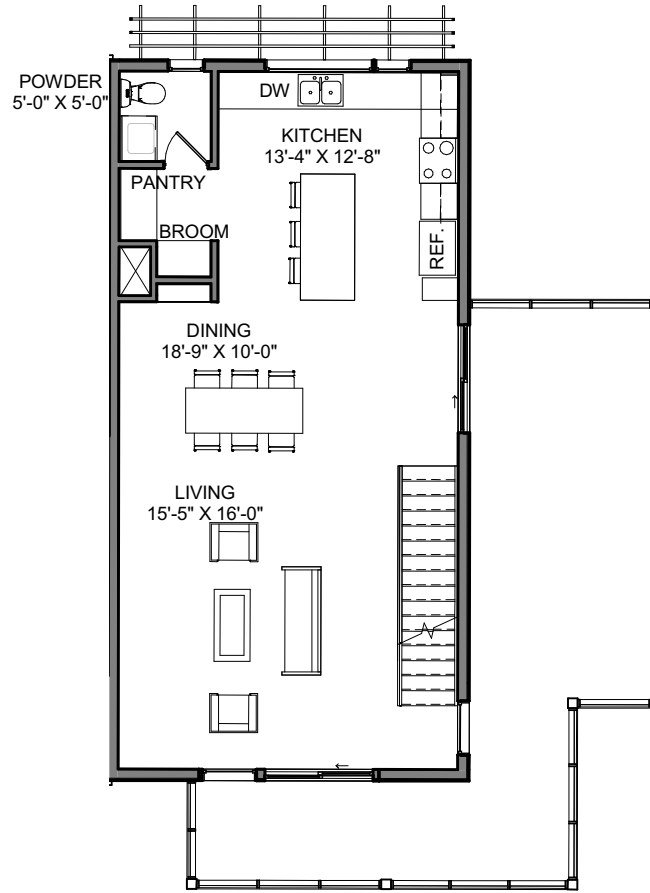

SECOND FLOOR

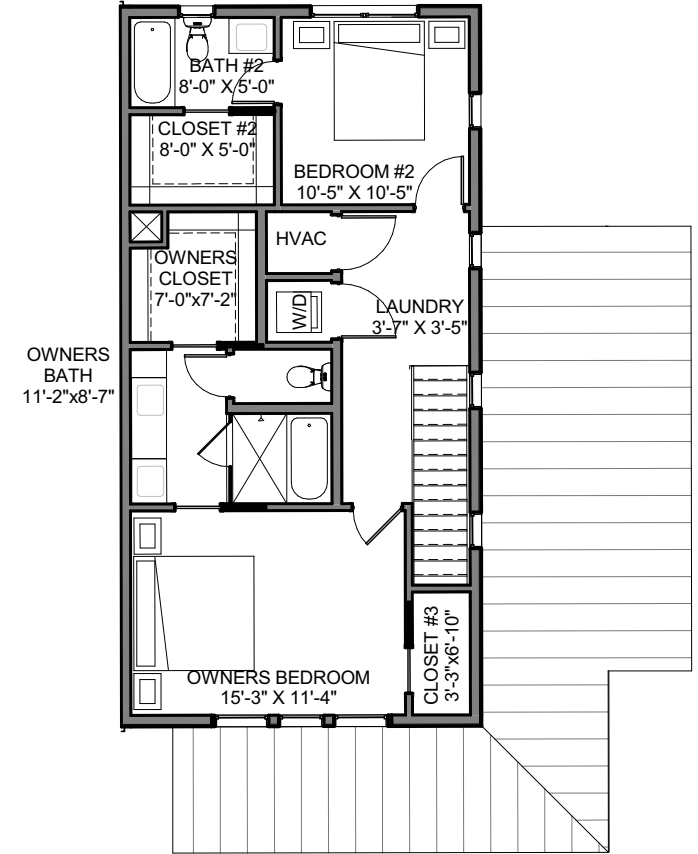

THIRD FLOOR

3/32" = 1'-0"

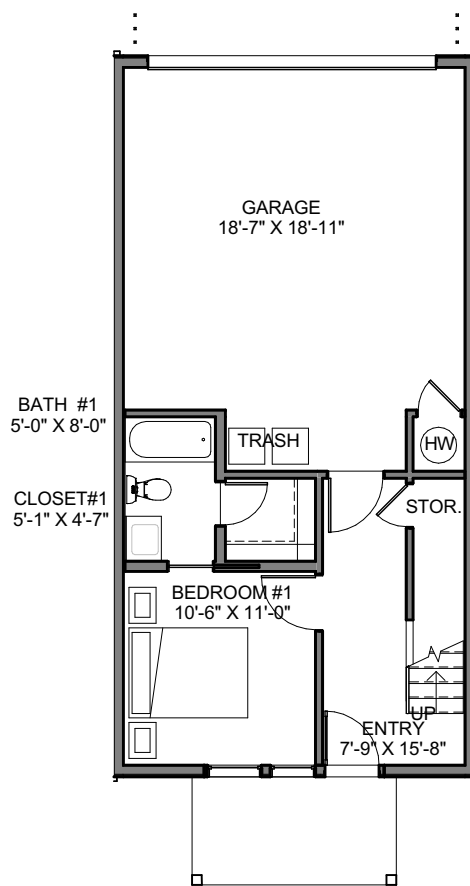

FIRST FLOOR

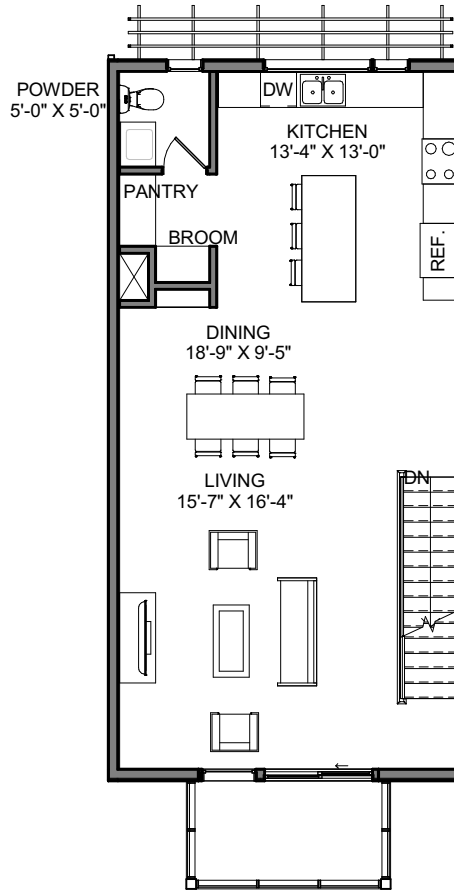

SECOND FLOOR

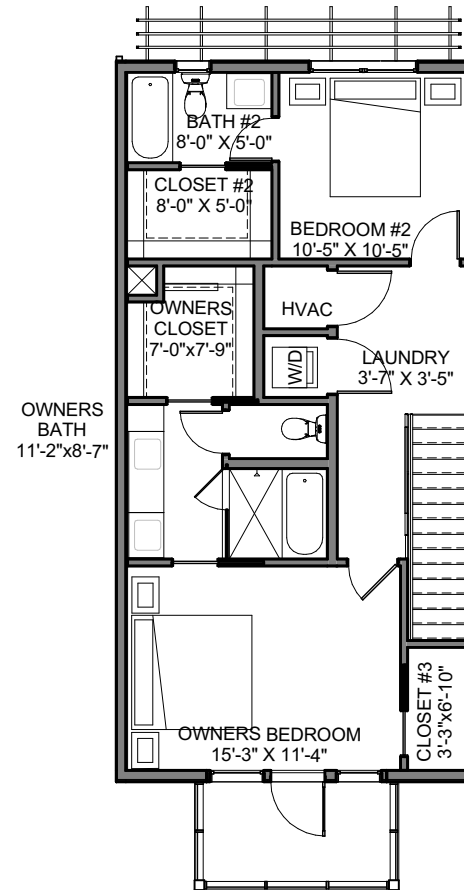

THIRD FLOOR

3/32" = 1'-0"

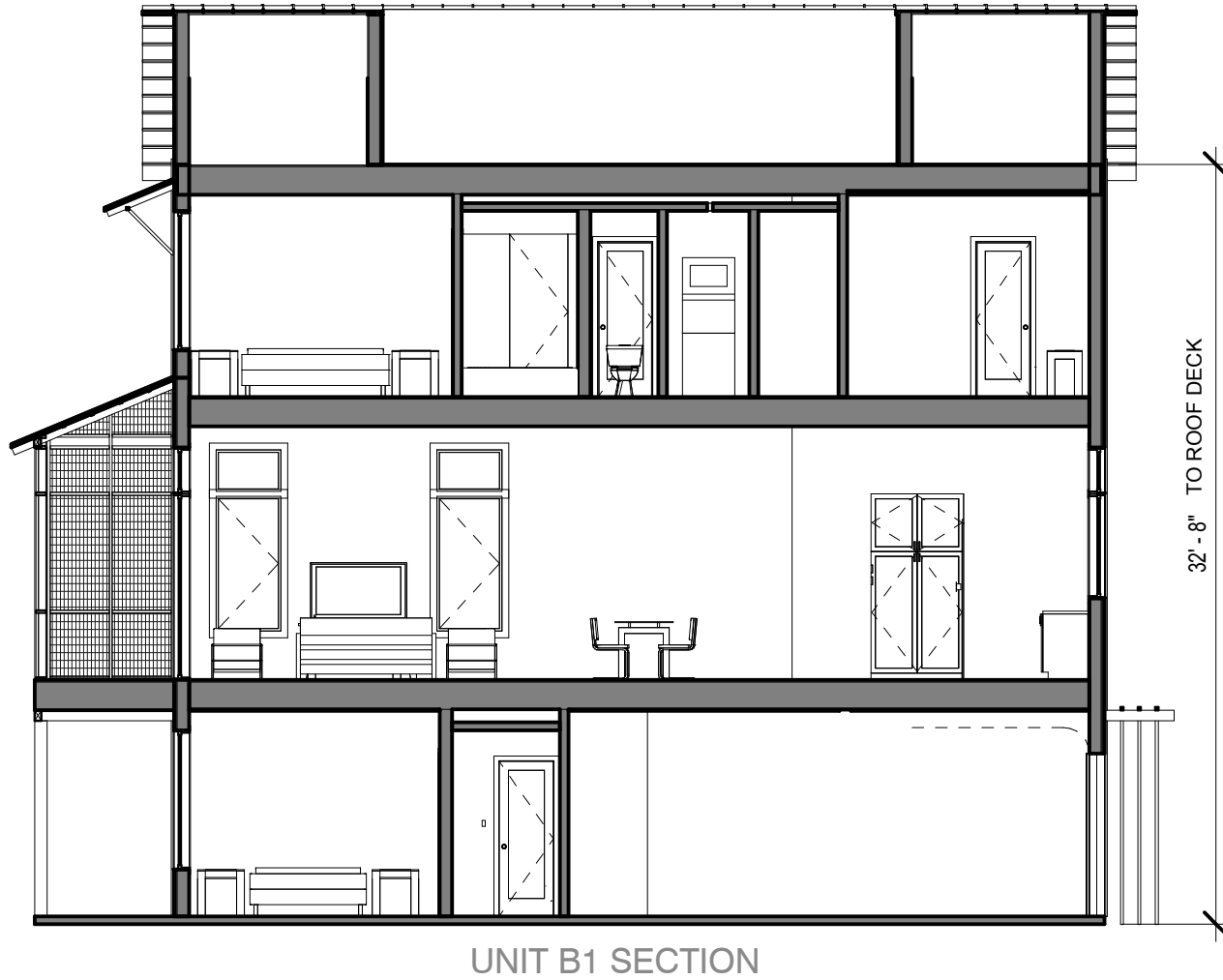

UNIT B1 SECTION

1/8" = 1'-0"

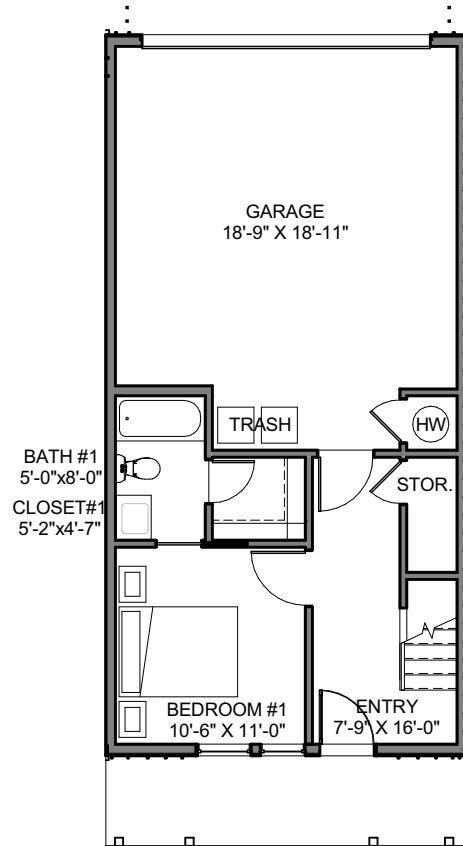

FIRST FLOOR

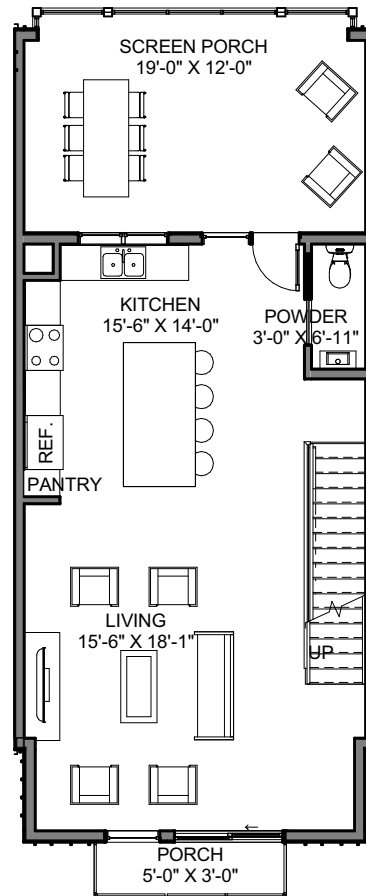

SECOND FLOOR

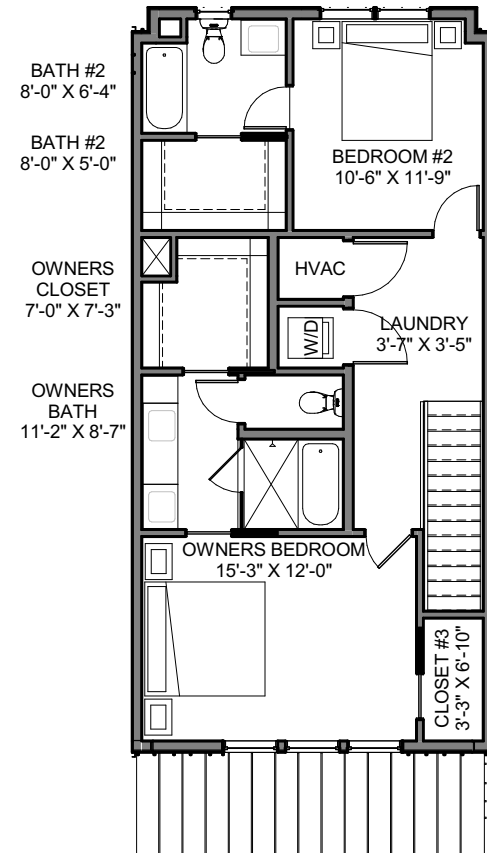

THIRD FLOOR

3/32" = 1'-0"

# ILLUSTRATIVE SECTIONS | TOWNHOME UNITS

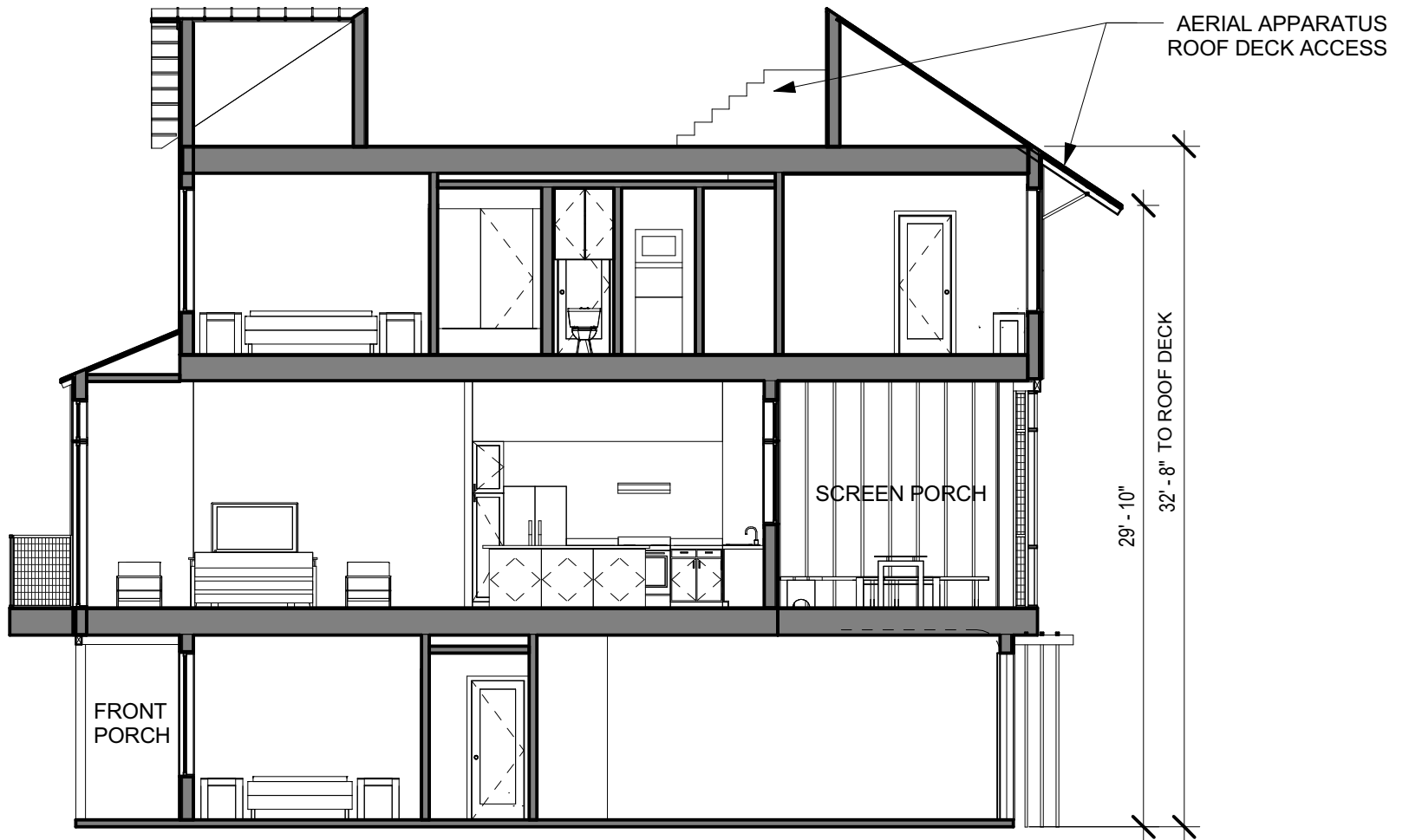

UNIT B2 SECTION

1/8" = 1'-0"

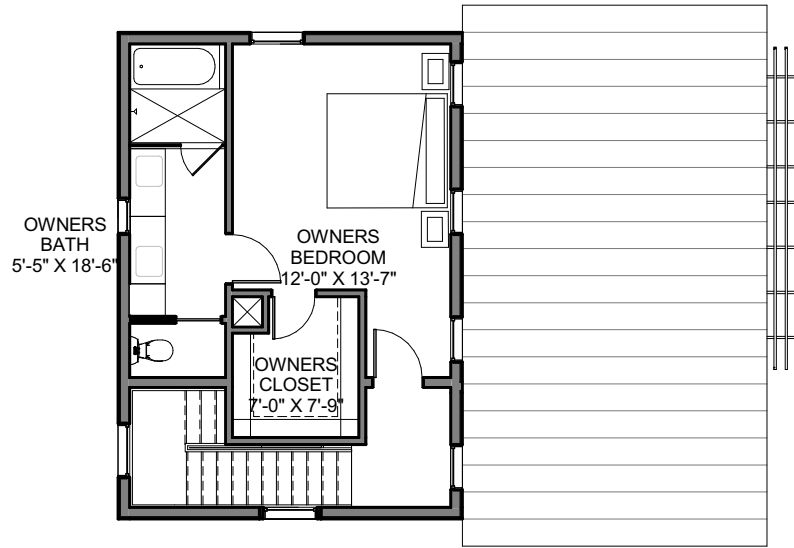

THIRD FLOOR

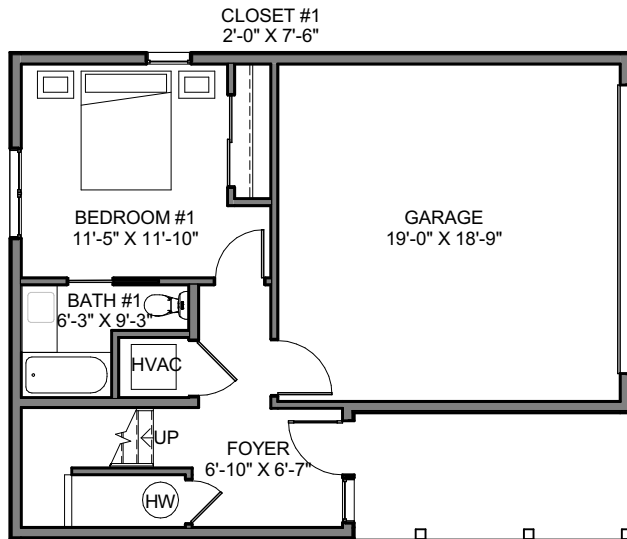

FIRST FLOOR

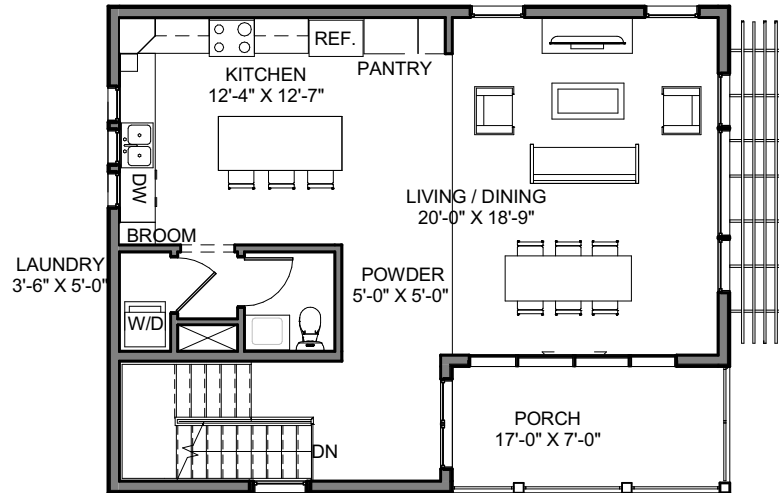

SECOND FLOOR

3/32" = 1'-0"

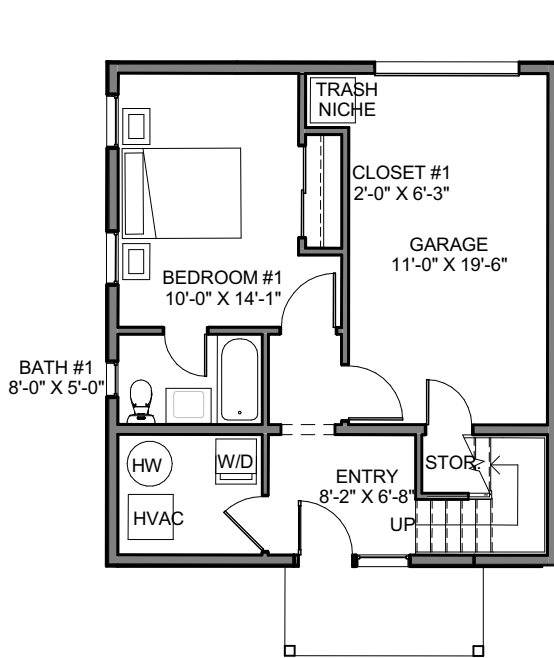

FIRST FLOOR

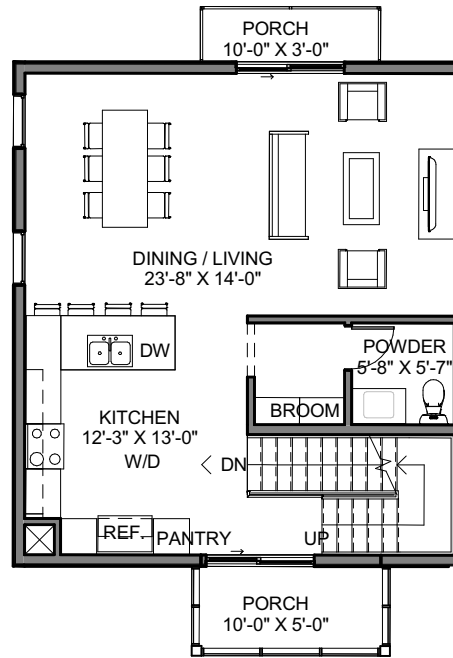

SECOND FLOOR

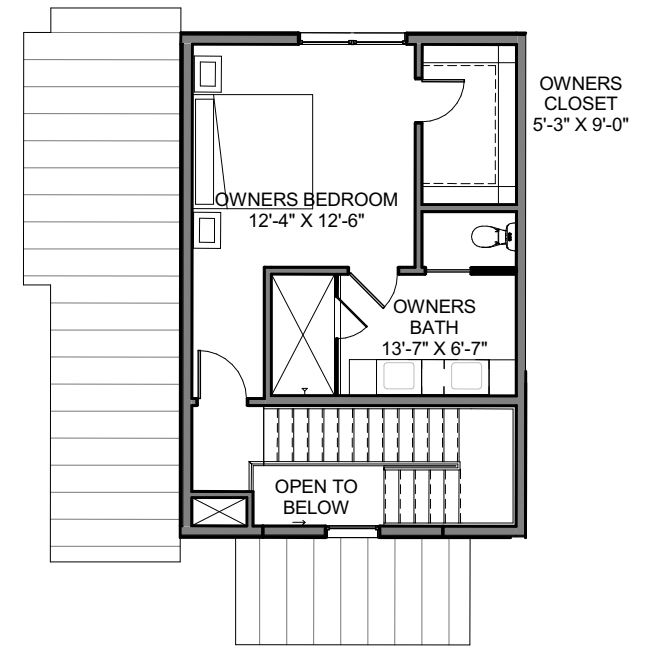

THIRD FLOOR

3/32" = 1'-0"



**ILLUSTRATIVE SECTIONS** | DETACHED SINGLE FAMILY UNITS



UNIT C SECTION

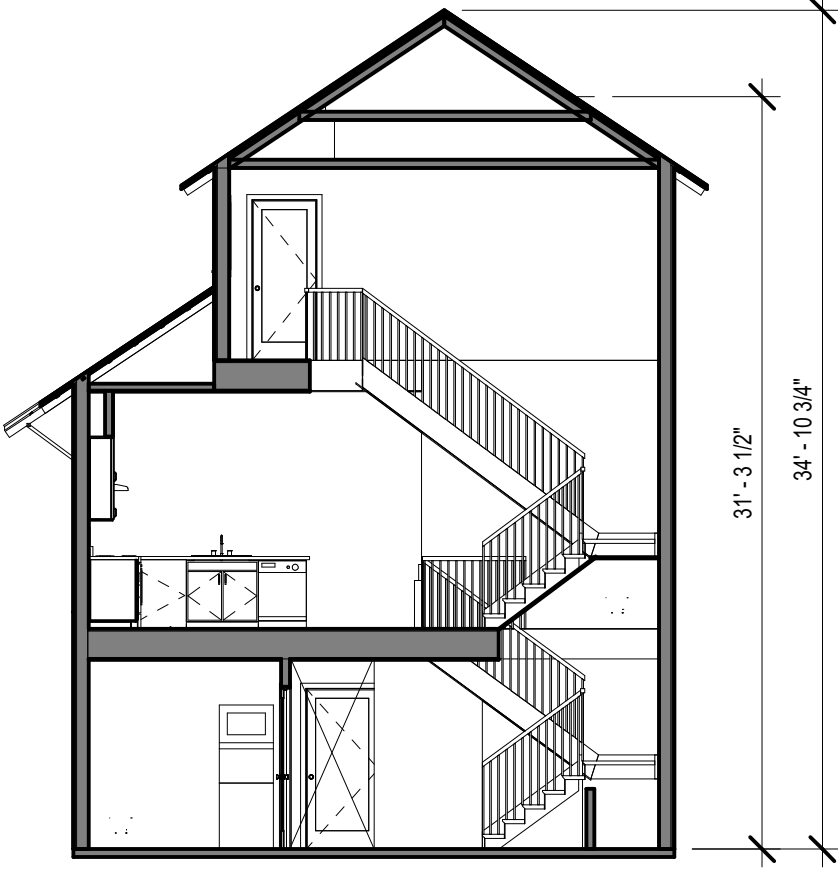

UNIT D SECTION

1/8" = 1'-0"



CITY OF SAN ANTONIO  
**OFFICE OF HISTORIC  
 PRESERVATION**

**Historic and Design Review Commission  
 Design Review Committee  
 Report & Recommendation**

DATE: 7/25/2017 HDRC Case# \_\_\_\_\_

ADDRESS: 1226 S. PRESA Meeting Location: OHP

APPLICANT: MARIO GONZALES - SOUTHTOWN ONE LTD

DRC Members present: KAMAL, CONE

Staff present: STEPHANIE PHILLIPS

Others present: MICKY CONRAD-LPA, LILIANA

REQUEST: TOWNHOME DEVELOPMENT

**COMMENTS/CONCERNS:** \_\_\_\_\_

LPA: ~~W~~ Future site - possibly relocate 1-story structure to corner.  
 Introducing several trees. 3 and 2.5 stories.

TC: mechanical well will drop ceiling / perceived roof height.  
 Addressed as corner. 3-story appropriate.

Along Presa - show where unit hits neighbor. Maybe  
 that one drops to 2.5 stories. Consider how 3-story hits  
 on all corners regarding neighbors.

**COMMITTEE RECOMMENDATION:** APPROVE [ ] DISAPPROVE [ ]  
**APPROVE WITH COMMENTS/STIPULATIONS:**

  
 Committee Chair Signature (or representative)

7/25/2017  
 Date

Vance elevations - how it's defined as an address.

A lot of wall. Address with materiality, potentially.

Recess 2nd-Floor terrace, & bring sloped roof back to main footprint? Change # of columns, stand out as porch.

AK: Handles odd lot size well.

Consider transitions & visibility. Don't rely on plants.

Consider porch barrier. 2 units on property line, vines, semi-opaque, etc.

Change of material & color on Florida elevation.

Break up continuity, more in line with the neighborhood.

TL: Windows: casement vs. double hung? Nod to proportions of neighborhood context.

Be wary of 3-story board + batten wall - Vance elevations.

Individually in the whole is good!

Look at historic door patterns