

**AN ORDINANCE**

**AMENDING CHAPTER 11, FIRE PREVENTION, OF THE CITY CODE OF SAN ANTONIO, TEXAS, ADOPTING THE 2015 EDITION OF THE INTERNATIONAL FIRE CODE AND APPENDICES B, C, D, F AND I, PROVIDING FOR LOCAL AMENDMENTS TO SAID CODE, AMENDING CHAPTER 16, SECTION 16-3, LICENSES AND BUSINESS REGULATIONS AND PROVIDING FOR PENALTIES, PUBLICATION AND AN EFFECTIVE DATE.**

\* \* \* \* \*

**WHEREAS**, the Fire Department currently enforces the 2012 edition of the International Fire Code published by the International Code Council, Inc. and the local amendments thereto; and

**WHEREAS**, the 2015 edition of the International Fire Code (IFC) has been published; and

**WHEREAS**, the Building-Related and Fire Codes Appeals and Advisory Board and city staff have conducted public meetings regarding the adoption of the 2015 IFC and local amendments thereto; and

**WHEREAS**, the Building-Related and Fire Codes Appeals and Advisory Board and the Fire Department recommend approval and adoption of the 2015 IFC with its local amendments; and

**WHEREAS**, all prerequisites required by state statute and the City Charter for adoption of this code and its amendments have been satisfied; **NOW THEREFORE**,

**BE IT ORDAINED BY THE CITY COUNCIL OF THE CITY OF SAN ANTONIO:**

**SECTION 1.** Chapter 11, *Fire Prevention Code*, and Chapter 16, *Licenses and Business Regulations* of the City Code of San Antonio, Texas, are hereby amended by adding the underlined (added) language and deleting the stricken (~~deleted~~) language:

**SECTION 2.** Chapter 11, Article I, Section 11-16 (a)(7) is hereby amended as follows:

**Sec. 11-16. Fees for certain permits and services.**

The following fees are hereby established for obtaining certain permits from the fire prevention division of the fire department.

- (7) LPG/CNG/LNG tanks:  
First tank on permit .....200.00  
Each additional tank ....100.00

**SECTION 3.** Chapter 11, Article III, entitled “Fire Prevention Code” sections 11-32 is amended as follows:

**Sec. 11-32. Adoption of the International Fire Code.**

The 2015 [~~2012~~] edition of the International Fire Code, including Appendices B, C, D, F and I developed by the International Code Council is hereby adopted by the City of San Antonio, Texas, [city] as the fire code for the City from the effective date hereof and shall govern all activities specified therein for the purpose of prescribing regulations governing conditions hazardous to life and property from fire and explosion. The 2015 [~~2012~~] edition of the International Fire Code as adopted is incorporated by reference in this article.

**SECTION 4.** Chapter 11, Article III, Section 11-40 entitled “Amendments made to the 2012 International Fire Code” is hereby repealed and replaced with a new section 11-40 entitled “Amendments made to the 2015 International Fire Code,” as detailed below.

**Sec. 11-40. Amendments made to the 2015 [~~2012~~] International Fire Code.**

*Section [A]102.3.1 Notice of Alteration to be given to Fire Chief, is added to read as follows:*

**[A]102.3.1 Notice of Alteration to be given to Fire Chief.** The Director of the Development Services Department shall provide written notice to the Fire Chief of every application made to repair, alter, or remodel any occupancy and any building or structure with the exception of single family and two family dwellings.

*Section [A]102.9 is amended by adding 102.9.1 Fire Chief Authorization as follows:*

**[A]102.9.1 Fire Chief Authorization** The Fire Chief is authorized to make and enforce such rules and regulations for the prevention and control of fires and fire hazards as may be necessary from time to time to carry out the intent of this Code. Three certified copies of such rules and regulations shall be filed with the City Clerk of the City of San Antonio and shall be in effect immediately thereafter and additional copies shall be kept in the office of the Fire Department for distribution to the public.

*Section 104 GENERAL AUTHORITY AND RESPONSIBILITIES, is amended by adding Section [A]104.1.1 entitled Authority of the Fire Chief and the Fire Department and Section [A]104.1.2 entitled Additional Duties and Police Powers of Fire Department Members as follows:*

**[A]104.1.1 Authority of the Fire Chief and the Fire Department.** The Fire Chief is duly authorized to act by any means he deems necessary to protect life and property from fire hazards. The Fire Chief may delegate his power to any other member of the Fire Department.

**[A]104.1.2 Additional Duties and Police Powers of Fire Department Members.** In addition to the duties required or prescribed for members of the Fire Department in connection with the regular functions of such department, when so required by order of the City Manager in case of riots, floods, or other public emergencies or catastrophes or public danger of any sort, and all fires by order of the Fire Chief, Deputy Chief, Assistant Chief, District Chief, or any Captain or Lieutenant of the Fire Department, each and all members of the Fire Department shall be and become vested with full Police powers and shall perform all duties required for the protection of persons or property or the preservation of public safety, peace and order.

*Section [A] 104.3 Right of Entry is amended by including the owner's agent in the first paragraph and adding a second paragraph in order to read as follows:*

**[A]104.3 Right of Entry.**

Whenever it is necessary to make an inspection to enforce the provisions of this code, or whenever the *fire code official* has reasonable cause to believe that there exists in a building or upon any premises any conditions or violations of this code which make the building or premises unsafe, dangerous or hazardous, the *fire code official* shall have the authority to enter the building or premises at all reasonable times to inspect or to perform the duties imposed upon the *fire code official* by this code. If such building or premises is occupied, the *fire code official* shall present credentials to the occupant and request entry. If such building or premises is unoccupied, the *fire code official* shall first make a reasonable effort to locate the owner, the owner's authorized agent or other person having charge or control of the building or premises and request entry. If entry is refused, the *fire code official* has recourse to every remedy provided by law to secure entry.

No owner or occupant or any other person having charge, care or control of any building or premises shall fail or neglect, after proper demand is made as herein provided, to properly permit entry therein by the Chief or his authorized representative for the purpose of inspection or examination under such exigent circumstances affecting the safety of persons and/or property, or to take such prudent action to extinguish a fire or abate a fire hazard.

*Section [A] 104.3 Right of Entry, is amended by adding [A]104.3.2 entitled Photographic Documentation to read as follows:*

**[A]104.3.2 Photographic Documentation.** Members of the Fire Department making such examinations or inspections shall have the right, with proper credentials, and be authorized to take a reasonable number of photographs or videotapes for evidence and for records for use by the Fire Department to study hazards and scientific control for fire safety.

*Section [A] 104.4 Identification, is amended by adding [A]104.4.1 Impersonation to read as follows:*

**[A]104.4.1 Impersonation** A person shall not impersonate the fire code official or his designee through the use of a uniform, identification card, badge, or any other means. Any such impersonation shall be deemed a violation of this Code.

*Section [A]104.11 Authority at fires and other emergencies, is amended by adding [A]104.11.4 Removal of debris and rubble after fire to read as follows:*

**[A]104.11.4 Removal of debris and rubble after fire.**

1. The owner or person having under his control or in his possession upon any premises in the City, any hay, straw, bales of wool, cotton, paper or other substances which have been rendered useless or unmerchantable by reason of any fire on such premise, or any debris resulting from such fire, must remove such substances and debris from such premises within 48 hours after notice to do so has been served by the Fire Chief.
2. Whenever any building or other structure in the City is partially burned, the owner or the person in charge or control thereof shall, within 10 days after notice has been provided by the Fire Chief or Building inspector, remove all refuse, debris, charred and partially burned lumber and material from the site. If such building or other structure is burned to such an extent that it is rendered incapable of being repaired, the owner of the property upon which structure is located, or person in charge or control thereof, shall within ten days after notice has been provided by the Fire Chief or Building inspector, remove all the remaining portion of the building or structure, from the site.
3. The Fire Chief may extend the 10 day period of removal of such burned or partially burned buildings when the insurance adjustment, if any, is still pending.

*Section [A]105.2 Application is amended by adding [A]105.2.5 Investigation Fee/Working Without a Permit to read as follows:*

**[A]105.2.5 Investigation Fee/Working Without a Permit.** Work requiring a permit shall not commence until said permit is posted in a conspicuous place on

the job site and approved plans are available at this location. Where work is commenced prior to obtaining said permit, the fees provided for in Section 11-16 of the City Code may be doubled, but the payment of such double fee shall not relieve any person from fully complying with the requirements of Chapter 11 as amended by this ordinance in the execution of the work nor of any other penalties prescribed herein.

*Section [A] 105.3.1 Expiration, is deleted and replaced with a new Section [A] 105.3.1 Expiration to read as follows:*

[A]105.3.1 Expiration. An operational permit shall remain in effect until reissued, renewed, or revoked or for such a period of time as specified in the permit. Construction permits to install equipment utilized in connection with maintaining, storing or handling materials or processes which produce conditions hazardous to life or property or to install or modify any fire protection system or equipment or any other construction, equipment installation or modification in accordance with the provisions of the 2015 IFC where a permit is required by Section [A] 105.7 shall expire 180 days from the date of issuance.

**Exception:** Construction permits attached to, or in association with, the master commercial permit shall not be subject to the provisions of Section 105.3.1 and shall follow the expiration period of the master commercial permit if applicable.

*Section [A]105.4.2 Information on construction documents is amended by adding Section [A]105.4.2.2 entitled Occupancy Classification Letter as follows:*

[A]105.4.2.2 Occupancy Classification Letter. Two copies of a completed "Occupancy Classification Letter" (a.k.a. "Commodities Letter") or other approved Fire Protection report shall be submitted to the City for buildings or portions thereof that are to be used for any of the following purposes:

1. Warehousing or storage
2. Retail including rack display of products
3. Hazardous material storage and/or use
4. Manufacturing

The Occupancy Classification Letter is required to be submitted:

1. with the building permit submittal documents when seeking a building permit,
2. to the SAFD Fire Inspector during a Certificate of Occupancy inspection, or
3. at any other time when required by the fire code official.

The Occupancy Classification Letter is to be prepared by the owner and/or tenant of the building/space in question or a registered design professional. It is to be signed, dated and on company letterhead. If the Occupancy Classification Letter is prepared by a registered design professional representing the owner and/or

tenant of the building/space in question, the letter is to be countersigned by the owner and/or tenant. The Occupancy Classification Letter is to be kept on site at all times. Prior to a change in 1) the type or amount of hazardous material(s) used or stored, 2) the type or amount of storage or storage height or method, or 3) the manufacturing process, a revised Occupancy Classification Letter is to be submitted to the Fire Chief or his designee for review.

*Section 105.6 Required operational permits is amended as follows:*

**105.6 Required operational permits.** The fire code official is authorized to issue operational permits for the operations set forth in Sections 105.6.1 through 105.6.51. Required permits and associated fees are listed in Chapter 11, Section 11-16 and in Chapter 16 entitled Licenses and Business Regulations, Article I, In General, Sec. 16-3 for hazardous materials . Materials stored, used, dispensed, or handled in amounts exceeding the amounts listed in TABLE 105.6.9 PERMIT AMOUNTS FOR COMPRESSED GASES, TABLE 105.6.11 PERMIT AMOUNTS FOR CRYOGENIC FLUIDS, and TABLE 105.6.21 PERMIT AMOUNTS FOR HAZARDOUS MATERIALS are also subject to the provisions of this section.

*Section 105.6 Required operational permits is amended by amending Section 105.6.21 entitled Hazardous Materials, adding Section 105.6.49 entitled Food Booths, Section [A]105.6.50 entitled Mobile Food Establishments and Section [A]105.6.51 entitled Portable Outdoor Gas-fired Heating Appliances as follows:*

**105.6.21 Hazardous Materials.** An operational permit is required to store, transport on site, dispense, use or handle hazardous materials in excess of the amounts listed in Table 105.6.21. Permit fees are listed in Chapter 16 entitled Licenses and Business Regulations, Article I, In General, Sec. 16-3 for hazardous materials.

**105.6.49 Food Booths.**

An operational permit is required for the operation of a food booth. For permit to operate a food booth, see Section 320.

**[A]105.6.50 Mobile Food Establishments.**

An operational permit is required for the operation and maintenance of a mobile food establishment. Small, light weight vendor push carts, as determined by the fire code official, are not covered under this section. For permit to operate a Mobile Food Establishment, see Section 321.

**[A]105.6.51 Portable Outdoor Gas-fired Heating Appliances.**

An operational permit is required for the operation and maintenance of a portable outdoor gas-fired heating appliance. For permit to use portable outdoor gas-fired heating appliances, see Section 322.

*Section [A]105.7.8 is amended by adding Section 105.7.8.1 entitled Construction Documents as follows:*

**[A]105.7.8.1 Construction Documents.** The construction documents for the following tanks shall be prepared by a professional engineer licensed by the State of Texas:

1. Above ground storage tanks (AST) of 1320 gallons or larger used to store flammable liquids. (Class 1A,1B, 1C)
2. All underground tanks used for the storage and dispensing of flammable or combustible liquids.

*Section [A]105.7.12 is hereby amended as follows:*

**[A]105.7.12 LP-gas.** A construction permit is required for installation of or modification to an LP-gas system that contains 120 gallons or more. Maintenance performed in accordance with this code is not considered to be a modification and does not require a permit. Permit fee information can be found in Chapter 11, Section 11-16 of the City Code.

*SECTION 108 BOARD OF APPEALS is hereby repealed and replaced with a new section entitled SECTION 108 BUILDING-RELATED AND FIRE CODES APPEALS AND ADVISORY BOARD as follows:*

### **SECTION 108.**

#### **BUILDING-RELATED AND FIRE CODES APPEALS AND ADVISORY BOARD**

All Chapter 11 appeals and advisory opinions shall be directed to and addressed by the Building-related and Fire Codes Appeals and Advisory Board, as codified in Chapter 10, Section 10-14 of the City Code of San Antonio, Texas.

*Section [A]109.1 Unlawful acts, is amended by adding [A]Section 109.1.1 Work started without a Permit as follows:*

**[A]109.1.1 Work started without a Permit:** No work shall be started on any Fire Protection System at a new construction site or an existing structure, other than maintenance work, without a permit being issued, without a FAST TRACK permit being issued, or by approval to begin work by the Fire Marshal. Both the individual contractor along with the site general contractor may be held liable for such actions.

*Section [A]109.4 Violation penalties is hereby amended as follows:*

**[A]109.4 Violation penalties.** Persons who shall violate a provision of this code or shall fail to comply with any of the requirements thereof or who shall erect,

install, alter, repair or do work in violation of the *approved construction documents* or directive of the *fire code official*, or of a permit or certificate under provisions of this code shall be guilty of a Class C Misdemeanor as defined by the Municipal Code of the City of San Antonio [~~SPECIFY OFFENSE~~], ~~punishable by a fine of not more than [AMOUNT] dollars or by imprisonment not exceeding [NUMBER OF DAYS], or both such fine and imprisonment~~. Each day that a violation continues after notice has been served shall be deemed a separate offense.

*Section [A]110.2 Evacuation is amended by adding [A]110.2.1 Removal of Occupants:*

[A]110.2.1 Removal of Occupants. A member of the Fire Department is authorized to require the removal of occupants at a location when actual occupancy exceeds the permitted or posted occupant load. A person commits an offense if he refuses to obey an order to vacate.

*SECTION 202, GENERAL DEFINITIONS is amended by adding definitions and modifying existing ones as follows:*

## SECTION 202

### GENERAL DEFINITIONS

ADMINISTRATOR is the City Manager for the City of San Antonio.

AUTHORIZED EMERGENCY VEHICLE shall have the meaning set out in the Texas Transportation Code § 541.201.

DESIGNATED PREMISES shall mean property being used for a purpose allowed as a permitted use in an Apartment District, Office District, Local Retail District, Business District, Commercial District, Manufacturing District, Multiple Family Residence District, Mobile Home District, Townhouse Residence District, Industry District, or Planned Unit Development District as those terms are used in Chapter 35 of the City Code of San Antonio, Texas, whether or not the premises are so zoned, or a public or private school, or a church, or a facility owned or operated by the City or Bexar County or by a city-owned utility, where off-street parking is provided on the premises for occupants thereof and others.

[B] FIRE AREA. The aggregate floor area enclosed and bounded by *fire walls, fire barriers, exterior walls* or *horizontal assemblies* of a building. Areas of the building not provided with surrounding walls shall be included in the fire area if such areas are included within the horizontal projection of the roof or floor next above.



**Exception:** Outdoor covered areas shall not be considered *fire areas* nor shall they be considered as part of the *fire area* of a connected building where all of the following conditions are met:

1. The outdoor covered area is a Group A2 Occupancy less than 1,000 ft<sup>2</sup> or is a Group A3 Occupancy. If multiple Group A2 Occupancy outdoor covered areas are proposed, then the aggregate area of all of these areas shall be less than 1,000 ft<sup>2</sup> or separated by a minimum of 20 feet from each other.
2. The outdoor covered area is open on at least three sides and open a minimum of 50 percent of the perimeter of the area covered. In order to be considered “open” for the purpose of this exception, an open side shall be at least 50 percent open with the open area uniformly distributed to prevent the accumulation of smoke and toxic gases.
3. The outdoor covered area shall have adequate independent means of egress such that the occupants of the outdoor covered area are not required to egress through a connected or adjacent building.

FESTIVAL SEATING shall mean a form of audience/spectator accommodation in which no seating, other than a floor or ground surface, is provided for the audience/spectators gathered to observe a performance.

FIRE LANE shall mean any area appurtenant to entrances or exits of a building deemed necessary by the Fire Chief or his designee to remain free and clear of parked vehicles for access to such building in case of fire or other emergency and designated by him as such, and may include sidewalks, driveways, portions of parking lots, or any other area adjacent to or near building entrances or exits, or any fire hydrant. [A road or other passageway developed to allow the passage of fire apparatus. A fire lane is not necessarily intended for vehicular travel other than fire apparatus.]

FIRE MARSHAL shall mean the fire code official responsible for investigations of fires, inspection of facilities, and code enforcement.

FIRE WATCH. A temporary measure intended to ensure continuous and systematic surveillance of a building or portion thereof by one or more qualified individuals for the purposes of identifying and controlling hazards, detecting early signs of unwanted fire, raising an alarm of fire and notifying the fire department. Qualified individuals are defined as State Certified Fire Inspectors assigned to the Fire Prevention Division of the City of San Antonio, or, if approved by the Fire Marshal, Texas Certified Firefighters, Peace Officers, individuals employed by a private security firm, or other designated individuals whose sole duty when assigned a fire watch is to perform constant patrols of the premises and keep watch for signs of unwanted fire. A written log must be maintained and personnel

must have at least one approved means of notifying the fire department of fire or other emergencies.

FOSTER CARE FAMILY HOME shall mean a single independent residential occupancy that is the primary residence of the caregiver and licensed by the state to provide twenty four (24) hour care for six or fewer children (including those related to the caregiver) up to the age of eighteen (18) years.

MAINTENANCE AGREEMENT: A contractual agreement between a building owner and a licensed or registered firm to perform general maintenance work to life safety or fire protection or detection systems including, but not limited to, upgrades to an existing system that do not include modification to the existing system configuration and repair of fault conditions. Such an agreement may include provisions for testing and inspection in accordance with appropriate standards.

MOBILE FOOD ESTABLISHMENT shall mean a mobile food operation using any heat producing equipment to cook, fry, or warm products for consumption from a motorized vehicle, towable trailer, or watercraft.

MONITORING AGREEMENT: A contractual agreement between a building owner and a licensed or registered firm to provide monitoring service when required. Such service shall include either remote or central service.

NIGHT CLUB shall mean a *tavern* (as defined by the Unified Development Code, City of San Antonio, Texas) with more than 2,000 square feet of building area excluding kitchen, restrooms and storage areas. A nightclub use may include, in addition to the provision of alcohol for on premise consumption, a dance hall or dance floor, food services, and/or *live entertainment* (as defined by the Unified Development Code, City of San Antonio, Texas) as an accessory use when conducted less than 3 days per week. *Taverns* with less than 2,000 square feet of building area excluding kitchen, restrooms, and storage areas will be considered a nightclub for the purposes of this code if, in addition to the provision of serving alcohol for on premise consumption, the establishment provides all of the following:

1. Live entertainment (as defined by the Unified Development Code, City of San Antonio, Texas) or pre-recorded music, and
2. A dance floor and
3. Hours of operation that extend past 10:00 pm.

**Exceptions:** Restaurants with a tavern as an accessory use, or establishments with 501 (c)(3) non-profit, tax exempt status.

OCCUPANCY CLASSIFICATION. For the purposes of this code, certain occupancies are defined as follows:

**[BG] Business Group B.** Business Group B occupancy includes, among others, the use of a building or structure, or a portion thereof, for office, professional or service-type transactions, including storage of records and accounts. Business occupancies shall include, but not be limited to, the following:

Fire stations (including the dormitory, apparatus bays, living and offices areas) if installed with an automatic smoke detection system in accordance with 907.2.10.2 and smoke alarms installed in accordance with 907.2.11.2 through 907.2.11.4.

Food processing establishments and commercial kitchens not associated with restaurants, cafeterias and similar dining facilities not more than 2,500 square feet (232m<sup>2</sup>) in area.

**[BG] Residential Group R-3.** Residential Group R-3 occupancies where the occupants are primarily permanent in nature and not classified as Group R-1, R-2, R-4 or I, including:

Foster Care Family Homes

PARK shall mean the standing of a vehicle, whether occupied or not, upon a street otherwise than temporarily for the purpose of, and while actively engaged in, receiving or discharging passengers or loading or unloading merchandise or in obedience to traffic regulations, signs, or signals or an involuntary stopping of a vehicle by reason of a cause beyond the control of the operator of the vehicle.

SPECIAL EVENT shall mean an indoor or outdoor event that, in the opinion of the Fire Code Official or their designee, meets any of the following criteria:

1. Constitutes a use or occupant load ordinarily not permitted by the face of the Certificate of Occupancy.
2. Requires the means of egress to be altered from a configuration that was previously approved by the Building Code Official, Fire Code Official, or their designee (e.g., installation of booths, curtains, partitions, tables/chairs, etc. or the locking of select doors to limit access to portions of a building or area).
3. Poses a condition that compromises any life safety systems that were previously approved by the Building Code Official, Fire Code Official, or their designee (e.g., reduced lighting, increased sound levels, installation of alternate interior finishes, etc.).
4. Poses a condition that reduces the effectiveness of public safety services of any kind (e.g., Conditions that result in reduced access to fire hydrants, sprinkler riser/pump rooms, Fire Department Connections, etc.)."

NOTE: *Special Events* required to submit plans for each event (review and inspection) in accordance with **Section 11-16 *Special Event Inspection*** may

submit standard configuration plan packages to the San Antonio Fire Department Fire Prevention Division for review and inspection on an annual basis. Any deviation from the standard configuration as described in the above criteria will require new plans to be submitted for review each time the approved standard configuration is altered. Approved standard configurations for *Special Events* are required to be reviewed and inspected for code compliance once per year.

TESTING AND INSPECTION AGREEMENT: A contractual agreement between a building owner and a licensed or registered firm to perform testing and inspection work only for life safety or fire protection and detection equipment in accordance with appropriate standards.

*Section 304 Storage is amended by adding Section 304.2.1 Dangerous Storing of Combustibles to read as follows:*

**304.2.1 Dangerous Storing of Combustibles.** It shall be unlawful and a nuisance for any person to have or keep or store, within the city, any quantity of tar, pitch, resin, petroleum or its products, or other combustible materials or substances in such manner that such materials or substances shall be in danger of taking and communicating fire.

*Section 305.6 Ignited Materials in Streets Prohibited is hereby added as follows:*

**305.6 Ignited Materials in Streets Prohibited.** No person may place or possess burning materials on a street, alley, or public easement if that conduct creates a disturbance or causes a fire hazard.

*Section 307.1 General is amended by adding Section 307.1.2 Carrying Burning Materials as follows:*

**307.1.2 Carrying Burning Materials.** No person in the city shall carry or cause to be carried, in any street or other thoroughfare, any burning coal or firebrands, unless the same is shut up in a covered vessel.

*Section 307.2 Permit Required is amended by adding Section 307.2.2 Burning Rubbish, Brush and Other Combustible Matter as follows:*

**307.2.2 Burning Rubbish, Brush and Other Combustible Matter.**

- 1. Unlawful to burn trash without permit.** It shall be unlawful for any person to burn or cause to be burned, any trash, brush, tree limbs, grass, trees, leaves, paper, boards, planks, shavings, or any other combustible materials whatsoever within the corporate limits of the City, without first having a permit as required by subsection (2) of this section, unless the same is burned in an incinerator or container which has been approved in writing by the Fire

Chief or his designee, and said incinerator or container when used for burning shall be located in such a way that no smoke shall go into surrounding buildings, nor shall the operation of said incinerator or container create a fire hazard to the surrounding property.

2. **Application for a permit.** Any person desiring to burn any trash or other combustible material within the City shall make application to the Fire Chief or his designee for a permit to burn said materials. The application for a permit shall contain the following information:
  - a. The name, address and telephone number of the person making application for permit.
  - b. The type of material and the quantity to be burned.
  - c. The location in the City at which the material is to be burned and the legal description of the property together with the name and owner of the property.
  - d. The date on which the material is to be burned and the time at which the burning will commence and the estimated time necessary to complete the burning.
  - e. A statement by the person making the application that he assumes all liability and responsibility for all damages to all persons and property by reason of the fire, and that he will take all necessary precautions to ensure that no damages result from the fire.
  - f. A statement by the person making the application for a permit that he will burn the materials only on the date and at the time designated in the permit issued by the Fire Chief or his designee, and in accordance with any special instruction set forth in the permit issued by the Fire Chief's Office.
  
3. **Permit issued after investigation.** When an application to burn any trash or other combustible materials is made to the Fire Chief, and such burning is not a violation of air pollution standards, he shall make an inspection of the premises on which the material is to be burned and the surrounding property to determine if the burning, as requested by the applicant would be a fire hazard and dangerous to the adjoining or nearby property. If the Fire Chief, or his designee, finds from his inspection of the property that the burning would not be a fire hazard or danger to adjoining or nearby property, or violation of air pollution standards, he shall cause to be issued a permit which shall contain the following information and conditions:
  - a. The name, address and telephone number of the person to which the permit is issued.
  - b. The location, address and telephone number of the person for which the material is to be burned.
  - c. The date and time at which the material is to be burned.
  - d. A statement that the applicant assumes all liability and responsibility for all damages to all persons and property by reason of the fire.

- e. That the fire will not be left unguarded at any time during the burning and that an adult person shall be in attendance at all times.
  - f. Any condition which the Fire Chief or his designee find from the surrounding circumstances to be necessary to prevent the fire from being a fire hazard and a danger to adjoining or nearby property.
4. **When not to issue a permit.** No permit shall be issued for the burning of any materials at any time except during the day between one hour after sunrise and one hour before sunset, except for ceremonial bonfires, when:
- a. The site of the bonfire has been approved by the Fire Chief or his designee; and
  - b. The bonfire is held under the supervision of Fire Department personnel. Failure of any person or persons at such a bonfire to adhere to fire safety instructions and requirements of the Fire Department representative assigned to supervise same shall constitute a violation of this chapter. No permit shall be issued if the burning would be contrary to the provisions of this section, nor shall such permit be issued if the Fire Chief, or his designee, shall have reason to believe that weather conditions, type or location of the materials to be burned, or the use of property within the area affected would cause the burning to be a hazard or otherwise violate the provisions of this section.

*Section 308.1.4 Open-flame cooking devices is amended by deleting exception 2 and renumbering as follows:*

**308.1.4 Open-flame cooking devices.** Charcoal burners and other open-flame cooking devices shall not be operated on combustible balconies or within 10 feet (3048 mm) of combustible construction.

**Exceptions:**

- 1. One-and two-family dwellings.
- ~~[2. Where buildings, balconies and decks are protected by an automatic sprinkler system]~~
- 2. [3.] LP-gas cooking devices having LP-gas container with a water capacity not greater than 2 ½ pounds [nominal 1 pound (0.454 kg) LP-gas capacity].

*Section 308.1 General is amended by adding Section 308.1.9 Projection of Ignited Materials as follows:*

**308.1.9 Projection of Ignited Materials.** No person shall drop or throw ignited material from a structure or vehicle.

*Section 308 OPEN FLAMES, is amended by adding Section 308.5 entitled Fire Hazard Prohibited as follows:*

**308.5 Fire Hazard Prohibited.** In Group R, Division 1 & 2 occupancies, a person shall not construct, erect, install, maintain or use any incinerator or barbecue pit or grill or so burn any combustible material as to constitute or occasion a fire hazard by the use or burning thereof or as to endanger the life or property of any person thereof.

The use or burning of any such devices under the following conditions shall constitute a fire hazard and is strictly prohibited:

1. Within 10 linear feet of any combustible surface, including but not limited to decks, porches, balconies, walls, or verandas.
2. Beneath any balcony, porch, roof overhang, deck, or veranda.

*Section 314.4 Vehicles, is amended to read as follows:*

**314.4 Vehicles.**

1. Batteries are disconnected.
2. Fuel in fuel tanks does not exceed one-quarter tank or 5 gallons (whichever is least) or for large diesel vehicles, minimum amount required to position vehicle. [~~19L~~] (whichever is least-)]
3. Fuel tanks and fill openings are closed and sealed to prevent tampering.
4. Vehicles, boats or other motorcraft equipment are not fueled or defueled within the building.

*Section 315.3.3 Equipment Rooms is amended to read as follows:*

**315.3.3 Equipment Rooms.** Combustible material shall not be stored in boiler rooms, mechanical rooms, electrical equipment rooms, or in fire command centers as specified in Section 508.1.5, nor within 10 feet of any furnace or boiler room door.

*CHAPTER 3 GENERAL REQUIREMENTS is amended by adding a new Section 319 PARADE FLOATS to read as follows:*

**SECTION 319**  
**PARADE FLOATS**

**319.1 Decorative Materials.** Decorative material on parade floats shall be noncombustible or flame retardant.

**319.2 Fire Protection.** Motorized parade floats and towing apparatus shall be provided with a minimum 2-A, 10-B:C-rated portable fire extinguisher readily accessible to the operator.

**319.3 Exhaust Pipes.** Motorized float exhaust pipes must be extended past the exterior of the float and be clear of all decorative material.

**319.4 Escape Hatch.** Motorized floats shall be equipped with a quick escape hatch from interior driver compartments.

*CHAPTER 3 GENERAL REQUIREMENTS is amended by adding a new Section 320 FOOD BOOTHS as follows:*

**SECTION 320**  
**FOOD BOOTHS**

**320.1 Permits.** For permit to operate a food booth, see Section 105.6.47. It shall be unlawful to operate a food booth without a permit.

**320.2 Fire Extinguishers.** One 2A-10 BC fire extinguisher shall be required for all food booths. Booths containing deep fat fryers shall have a class K portable fire extinguisher for up to four fryers having a maximum cooking medium capacity of 80 pounds each. For every additional group of four fryers having a maximum cooking capacity of 80 pounds each, an additional class K extinguisher will be required. For individual fryers exceeding 6 square feet in surface area, class K extinguishers will be installed in accordance with manufacturers' recommendations. All fire extinguishers shall have a current (within a year) inspection sticker from a licensed extinguisher company or provide proof that the extinguisher is new (store receipt).

**320.3 Location.** Food booths utilized for cooking shall have a minimum of 10 feet clearance on two sides. Booths shall not be placed in fire lanes unless otherwise approved by the fire code official. Booths shall not be placed within 10 feet of amusement rides or devices.

**320.4 Cooking equipment location.** Barbeque pits shall not be located within 10 feet of combustible materials. Barbeque pits shall not be located under the food booth canopy.

**320.5 Acceptable Cooking Sources.** The following are the only approved cooking sources for food booths:

1. Wood or charcoal
2. Propane
3. Natural Gas
4. Electricity

**320.6 Generators.** Fuel tanks shall be of adequate capacity to permit uninterrupted operation during normal operating hours. Generators shall be isolated from contact with the public. Storage of gasoline is not allowed in or near generators or food booths.



**320.7 Decorations.** All decorative material shall be at least six feet away from any open flame, cooking element, or heat source or be flame resistant.

**320.8 Escape route.** All concession stands shall have a minimum of a three ft. aisle for emergency escape.

**320.9 Propane.** All equipment used in conjunction with propane tanks must be UL Listed for the purposes in which they will be used. Tanks shall be secured to prevent falling. Tanks shall only be white or aluminum in color. Only one spare tank will be allowed in a food booth. Emptied propane tanks are to be removed from the site immediately after use. Regulators shall be attached to the tanks as close as possible. Leaks can be detected using a soap and water solution. Tank shutoff valves and/or additional shutoff valves shall be accessible and away from the cooking appliance(s). Propane tanks shall not be within five feet of an ignition source. Propane tanks shall not be located within 10 feet of a building door or window.

**320.10 Area.** A food booth shall consist of an area 10 feet by 10 feet. Extended food booths that exceed 10 feet by 10 feet space and used for cooking will be charged additional fees. These fees will be charged in one hundred square foot increments and any portion thereof.

*CHAPTER 3 GENERAL REQUIREMENTS is amended by adding a new Section 321 MOBILE FOOD ESTABLISHMENTS to read as follows:*

**SECTION 321**  
**MOBILE FOOD ESTABLISHMENTS**

**321.1 Permits.**

**321.1.1** It shall be unlawful to operate mobile food establishments without a permit as required by Section 105.6.50. Annual mobile food establishment permits must be displayed in a visible location in or on the mobile food establishment.

**321.1.2** Mobile food establishments left on site for more than 24 hours at carnivals, fairs, festivals, or other public events will be subject to Food Booth permit requirements, inspections, and fees as set forth in Section 320 and Section 105.6.49 of this code in addition to any fees associated with the annual mobile food establishment permits.

**321.2 Fire Extinguishers** - Fire extinguishers are required in mobile food establishments in accordance with sections 321.2.1 through 321.2.4

**321.2.1** All mobile food vendors shall have at minimum one (2A10BC) portable fire extinguisher mounted in a conspicuous place within the kitchen area.

321.2.2 Mobile food vendors with portable generators shall have a (3A40BC) portable fire extinguisher in addition to the other fire extinguishers.

321.2.3 All portable fire extinguishers shall be serviced, inspected, and tagged annually.

321.2.4 In addition to any other required fire extinguisher, all mobile food vendors who deep fat fry shall have a class K portable fire extinguisher for up to four fryers having a maximum cooking medium capacity of 80 pounds each. For every additional group of four fryers having a maximum cooking capacity of 80 pounds each, an additional class K extinguisher will be required. For individual fryers exceeding six square feet in surface area, class K extinguishers will be installed in accordance with manufacturers' recommendations.

321.3 Use of LPG - Liquefied Petroleum Gas usage shall comply with sections 321.3.1 through 321.3.5.

321.3.1 L.P. Gas containers shall be located and secured on the exterior of the mobile food establishment, open to atmosphere or if containers are kept in compartment, said compartment must be separate from the interior food preparation area. Access must be from the exterior of the unit and compartment floor and exterior door must be vented to the atmosphere.

321.3.2 All mobile units with propane shall post a "NO SMOKING" sign next to or directly above the propane bottle and visible to the public. Such sign shall be posted with a minimum of four inch lettering.

321.3.3 Any hose used to pipe L.P. Gas to a device shall be listed by UL, FM, or other approved agency and listed specifically for LP Gas service. All couplings, fittings, and any other devices shall meet the requirements for LP Gas Service as outlined in the International Fuel Gas Code, NFPA 58 and 54, or be deemed unapproved and removed from service.

321.3.4 LPG tanks shall be located outside the mobile food establishment a minimum of five feet from the primary means of egress.

#### 321.4 Baffles and Closures

321.4.1 All deep-fat fryers shall have a steel baffle between the fryer and surface flames of an adjacent appliance or shall maintain a 16 inch separation distance. The baffle, if installed, shall be eight inches in height.

321.4.2 A positive closing lid shall be required on the fryer with latching mechanisms that secure it in the open and closed positions. Exception: fryers installed under a fixed pipe extinguishing system.

**321.5 Emergency Egress.** Emergency egress shall comply with Sections 321.5.1 through Section 321.5.2.2

**321.5.1** Mobile food establishments shall have a clear, unobstructed height over the aisle-way portion of the unit of at least 74 inches from floor to ceiling, and a minimum of 30 inches of unobstructed horizontal aisle space.

**321.5.2** Should travel distance from any portion of the interior exceed 10 feet, the mobile food establishments shall have a minimum of two exits located remote from each other and so arranged as to provide a means of unobstructed travel to the outside of the vehicle.

**321.5.2.1** A secondary means of egress shall be located remote of the main exit door, with an unobstructed minimum passage of 24" X 24 " to the outside. The bottom of this secondary means of egress shall not be more than four feet above the vehicle floor or a readily accessible horizontal surface capable of supporting a weight of 300 pounds minimum opening to the outside.

**321.5.2.2** The latch mechanism of any exit facility shall be operable by hand, and shall not require the use of a key or special knowledge for operation from the inside. The secondary exit shall be labeled with the word "EXIT" with two inch minimum letters on contrasting background.

### **321.6 Generator Refueling**

**321.6.1** Refueling of generators shall be performed in an approved location not less than 20 feet from the mobile food establishment. Fuel shall be stored in a UL or FM approved flammable liquid safety container in an approved location. Generators shall be grounded in an approved method. Generators shall not be refueled in areas occupied by the public.

*Chapter 3 GENERAL REQUIREMENTS is amended by adding a new Section 322 PORTABLE OUTDOOR GAS-FIRED HEATING APPLIANCES to read as follows:*

## **SECTION 322** **PORTABLE OUTDOOR GAS-FIRED HEATING APPLIANCES.**

### **322.1 General Requirements.**

1. It shall be unlawful to operate portable outdoor gas-fired heating appliances without a permit as required by Section 105.6.51.
2. Portable outdoor gas-fired heating appliances must comply with Section 603.4 of this code.

3. One 2A10BC fire extinguisher installed in accordance with NFPA 10 and Section 906 of this code must be provided for every 3000 square feet of area where portable outdoor gas-fired heating appliances are used. The maximum travel distance to a fire extinguisher is not to exceed 75 feet.

*Section 403.2 Group A occupancies is amended by adding a new Section 403.2.5 Exhibition Halls - General to read as follows:*

**403.2.5 EXHIBIT HALLS - GENERAL.** The operator of premises used as a place of exhibition shall:

1. Notify each lessee of the Fire Code requirements at the time the lease is made;
2. Where required by the Fire Chief or his designee, submit to the Fire Chief or his designee, 15 days before public operation, a detailed explanation of the nature of the operation and two copies of accurately scaled floor plans which show:
  - a. The exhibit layout;
  - b. Aisles;
  - c. Exits;
  - d. Exhibits;
  - e. Show decorator's booth;
  - f. Location and nature of fire extinguishing equipment; and
  - g. Dates when open to the public or trade.
3. Construct, operate, and maintain the exhibition in a manner satisfying this code and the approved plans.
4. Shall employ one or more certified fire inspector(s) of the SAFD as required and approved by the Fire Marshal, to be on duty at such place whenever, in the opinion of the Fire Marshal, it is essential for public safety.
5. A floor plan of display area must be submitted to the Fire Marshal at least 15 days prior to the event for approval.

*Section 403.2 Group A occupancies is amended by adding a new Section 403.2.6 Sitting or Standing in Aisles Prohibited as follows:*

**403.2.6 Sitting or Standing in Aisles Prohibited.** The operator of premises used as a place of assembly shall prevent the sitting or standing in aisles, passageways, or stairways while the premises are occupied.

*Section 403.2.Group A occupancies is amended by adding a new Section 403.2.7 Automotive Vehicles: Equipment in Exhibit Halls as follows:*

**403.2.7 Automotive Vehicles: Equipment in Exhibit Halls.** The operator of and exhibitors at premises used as a place of exhibition may display automotive vehicles and equipment inside a structure if:

1. The amount of fuel in the vehicle or equipment fuel tanks is limited to the greater of:
  - a. The minimum amount adequate for vehicle positioning; or
  - b. One quarter tank or five gallons, whichever is less
2. Vehicle or equipment tanks are effectively locked or adequately sealed;
3. Vehicle or equipment battery cables are disconnected from the ignition systems;
4. Vehicle or equipment ignition keys are possessed at all times by a responsible person at the display location;
5. Vehicle operation is limited to brief parade type displays as specifically approved by the Fire Marshal;
6. Show vehicles with LPG tanks shall not be permitted inside the exhibit halls.

*Section 403.2 Group A occupancies is amended by adding a new Section 403.2.8 Cooking and food-warming devices in exhibit booths as follows:*

**403.2.8 Cooking and food-warming devices in exhibit booths.**

1. Gas-fired devices shall comply with the following:
  - a. Natural gas-fired devices shall be in accordance with NFPA 54, National Fuel Gas Code, or NFPA 58, Liquefied Petroleum Gas Code.
  - b. The use of LP-Gas cylinders shall be prohibited.
  - c. Nonrefillable LP-Gas cylinders shall be approved for use where permitted by the authority having jurisdiction.
2. The devices shall be isolated from the public by not less than 48 in. (1220 mm) or by a barrier between the devices and the public.
3. Single-well cooking equipment using combustible oils or solids shall meet the following criteria:
  - a. They shall have lids available for immediate use.
  - b. They shall be limited to two ft<sup>2</sup> (0.2 m<sup>2</sup>) of cooking surface.
  - c. They shall be placed on noncombustible surface materials.
  - d. They shall be separated from each other by a horizontal distance of not less than 24 in. (610 mm).
  - e. They shall be kept at a horizontal distance of not less than 24 in. (610 mm) from any combustible material.
4. A portable fire extinguisher shall be provided within the booth for each device or an approved automatic extinguishing system shall be provided.

*Section 403.2 Group A occupancies is amended by adding a new Section 403.2.9 Waiting Spaces as follows:*

**403.2.9 Waiting Spaces.** In theaters and other assembly occupancies where persons are admitted to the building at times when seats are not available or when

the permitted occupant load has been reached and persons are allowed to wait in a lobby or similar space until seats or space is available, the following requirements shall apply:

1. Such use of a lobby or similar space shall not encroach upon the required clear width of exits.
2. The waiting spaces shall be restricted to areas other than the required means of egress.
3. Exits for waiting spaces shall be in addition to the exits specified for the main auditorium area.

*Section 403.2 Group A occupancies is amended by adding a new Section 403.2.10 Life Safety Evaluation as follows:*

**403.2.10 Life Safety Evaluation.** Where the occupant load of an assembly occupancy exceeds 6000, a life safety evaluation shall be performed. Where a life safety evaluation is required by other provisions of the Code, it shall comply with the following:

1. The life safety evaluation shall be performed by persons acceptable to the authority having jurisdiction.
2. The life safety evaluation shall include a written assessment of safety measures for conditions listed in 403.2.11.
3. The life safety evaluation shall be approved annually by the authority having jurisdiction and shall be updated for special or unusual conditions.

*Section 408.2.Group A occupancies is amended by adding a new Section 403.2.11 as follows:*

**403.2.11.** Life safety evaluations shall include an assessment of the following conditions and the related appropriate safety measures:

1. Nature of the events and the participants and attendees
2. Access and egress movement, including crowd density problems
3. Medical emergencies
4. Fire hazards
5. Permanent and temporary structural systems
6. Severe weather conditions

7. Earthquakes
8. Civil or other disturbances
9. Hazardous materials incidents within and near the facility
10. Relationships among facility management, event participants, emergency response agencies, and others having a role in the events accommodated in the facility

*Section 403.2.Group A occupancies is amended by adding a new Section 403.2.12 Outdoor Facilities as follows:*

**403.2.12 Outdoor Facilities.** In outdoor facilities, where approved by the authority having jurisdiction, the number of occupants who are each provided with not less than 15 square feet (1.4 m<sup>2</sup>) of lawn surface shall be permitted to be excluded from the maximum occupant load of 6000 in determining the need for a life safety evaluation.

*Section 403.2.Group A occupancies is amended by adding a new Section 403.2.13 General Requirements for Access and Egress Routes Within Assembly Areas as follows:*

**403.2.13 General Requirements for Access and Egress Routes Within Assembly Areas.**

**403.2.13.1** Festival seating shall be prohibited within a building, unless otherwise permitted by the following:

1. Festival seating shall be permitted in assembly occupancies having occupant loads of 250 or less.
2. Festival seating shall be permitted in assembly occupancies where occupant loads exceed 250, provided that an approved life safety evaluation has been performed.

**403.2.13.2** Access and egress routes shall be maintained so that crowd management, security, and emergency medical personnel are able to reach any individual at any time, without undue hindrance.

*Section 403.2.Group A occupancies is amended by adding a new Section 403.2.14 Flame-Retardant Requirement as follows:*

**403.2.14 Flame-Retardant Requirements.**

403.2.14.1 Combustible scenery of cloth, film, vegetation (dry), and similar materials shall meet the requirements of NFPA 701, Standard Methods of Fire Tests for Flame Propagation of Textiles and Films.

403.2.14.2 Foamed plastics shall be permitted to be used only by specific approval of the authority having jurisdiction.

403.2.14.3 Scenery and stage properties on thrust stages shall be of noncombustible materials, limited-combustible materials, or fire-retardant-treated wood.

*Section 403.2 Group A occupancies is amended by adding a new Section 403.2.15 Exhibits as follows:*

**403.2.15 Exhibits.**

403.2.15.1 Exhibits shall comply with 403.2.15.2 through 403.2.15.6.3.

403.2.15.2 The travel distance within the exhibit booth or exhibit enclosure to an exit access aisle shall not exceed 50 ft (15 m).

403.2.15.3 The upper deck of multilevel exhibits exceeding 300 ft<sup>2</sup> (28 m<sup>2</sup>) shall have not less than two remote means of egress.

403.2.15.4 Exhibit booths shall be constructed of the following:

1. Noncombustible or limited-combustible materials.
2. Wood exceeding ¼ in. (6.3 mm) nominal thickness.
3. Wood that is pressure-treated, fire-retardant wood meeting the requirements of NFPA 703, Standard for Fire Retardant-Treated Wood and Fire-Retardant Coatings for Building Materials.
4. Flame-retardant materials complying with NFPA 701, Standard Methods of Fire Tests for Flame Propagation of Textiles and Films.
5. Foamed plastics and materials containing foamed plastics having a heat release rate for any single fuel package that does not exceed 100 kW where tested in accordance with UL 1975, Standard for Fire Tests for Foamed Plastics Used for Decorative Purposes.
6. Cardboard, honeycombed paper, and other combustible materials having a heat release rate for any single fuel package that does not exceed 150 kW where tested in accordance with UL 1975, Standard for Fire Tests for Foamed Plastics Used for Decorative Purposes.



403.2.15.5 Curtains, drapes, and decorations shall comply with section 807.1.

403.2.15.6 Acoustical and decorative material including, but not limited to, cotton, hay, paper, straw, moss, split bamboo, and wood chips shall be flame-retardant treated to the satisfaction of the authority having jurisdiction and conforming to flame-proofing requirements of the NFPA.

403.2.15.6.1 Materials that cannot be treated for flame retardancy shall not be used.

403.2.15.6.2 Foamed plastics, and materials containing foamed plastics and used as decorative objects such as, but not limited to, mannequins, murals, and signs, shall have a heat release rate for any single fuel package that does not exceed 150 kW where tested in accordance with UL 1975, Standard for Fire Tests for Foamed Plastics Used for Decorative Purposes.

403.2.15.6.3 Where the aggregate area of acoustical and decorative materials is less than 10 percent of the individual floor or wall area, such materials shall be permitted to be used subject to the approval of the authority having jurisdiction.

*Section 403.2.Group A occupancies is amended by adding a new Section 403.2.16 as follows:*

403.2.16 Open flame devices within exhibit booths shall comply with section 308.

*Section 404.2.3.1 Lockdown plan contents is amended to read as follows:*

**404.2.3.1 Lockdown plan contents.** Lockdown plans shall be approved by the fire code official prior to implementation and shall include the following.

1. Initiation. The plan shall include instructions for reporting an emergency that requires a lockdown.
2. Accountability. The plan shall include accountability procedures for staff to report the presence or absence of occupants.
3. Recall. The plan shall include a prearranged signal for returning to normal activity.
4. Communication and coordination. The plan shall include an approved means of two-way communication between a central location and each secured area.

*Section 405.2 Frequency is amended by adding a new Section 405.2.1 Fire Drill Records to read as follows:*

**405.2.1 Fire Drills for E Occupancies.** The operator of premises housing an E Occupancy shall conduct fire drills:

1. Without warning;
2. In a manner requiring:
  - a. all students to immediately leave the structure upon hearing the fire drill signal;
  - b. a roll call by classes outside the structure; and
  - c. doors to be closed as each area is evacuated;
3. In a manner simulating fire conditions;
4. In a manner prohibiting students from running or playing;
5. If approved, in a manner permitting security persons to remain inside the structure during drills;
6. Which include:
  - a. Complete checks of each section of the structure;
  - b. The use of varying evacuation routes;
  - c. Occasional simulation of blocked exits;
  - d. Provisions for calling the fire department; and
  - e. The use of varying drill times;
7. During weather which does not pose a health threat to students;
8. As an exercise in discipline and procedure, rather than speed; and
9. By pulling a manual pull station.

*Section 405.2 Frequency is amended by adding a new Section 405.2.2 Fire Drills for E Occupancies to read as follows:*

**405.2.2 Fire Drills for E Occupancies.** FIRE CHIEF'S POWER TO ORDER FIRE DRILL. The Fire Chief may require a fire drill at any E Occupancy at any time.

*Section 407 is hereby amended by amending 407.5 Hazardous Materials Inventory Statement and Section 407.6 Hazardous Materials Management Plan as follows:*

**407.5 Hazardous Materials Inventory Statement.** Where required by the fire code official, an application for a permit shall include a Hazardous Materials Inventory Statement (HMIS) [~~in accordance with Section 5001.5.2~~]. The HMIS shall comply with NFPA 1 annex D.

**407.6 Hazardous Materials Management Plan.** Where required by the fire code official, each application for a permit shall include a Hazardous Materials Management Plan (HMMP) [~~in accordance with Section 5001.5.1~~]. The HMMP

shall comply with NFPA 1 annex D. The fire code official is authorized to accept a similar plan required by other regulations.

*Section 501.3. Construction documents is hereby amended by adding Section 501.3.1 Site Plan to read as follows:*

**501.3.1 Site Plan.** Three copies of the Fire Protection Site Plan (labeled as such) shall be submitted with the construction documents when application is made for a building permit. Plans must be reviewed and approved by the Fire Marshal and/or fire plan review staff before a building permit is issued. One copy of the approved Fire Protection Site Plan will be retained by the City of San Antonio. The Fire Protection Site Plan shall be drawn to scale (no less than 1:60) and shall show and include, but not be limited to, the following:

1. Compass reading.
2. Property and/or lot lines.
3. Street frontages.
4. Location of all buildings (existing and proposed).
5. Fire apparatus access roads (i.e., fire lanes, aerial apparatus access roads) to buildings. Fire lanes shall be highlighted and shall include dimensions (width, turning radii, clearance to overhead obstructions, etc). The plans shall also show dimensions and calculations for evaluation of compliance with Section D105.3.
6. Fences, gates, walls, streams and other obstructions to firefighter access.
7. Location of all fire hydrants (existing and proposed). This shall include the direction and the distance to all hydrants not shown on the site plan, but within one thousand feet of the building to be protected.
8. Size (diameter and length) and locations of all fire main piping (proposed and existing). The pressure class and type of new pipe to be installed shall be identified.
9. The location, type, and size of backflow prevention devices, where installed.
10. Number of lanes, including turning lanes, of all adjacent streets and the location of medians as applicable.
11. Location of all automatic sprinkler and standpipe risers.
12. Location of Fire Department connection(s).
13. Size, type, and location of valves including post indicator valve (if they are located in a pit), control room automatic sprinkler system shut-off, etc.
14. Other water supplies.
15. Where required, type of protection from collision that may cause physical damage to fire protection equipment.

*Section 503.1.1 Buildings and facilities is amended to read as follows:*

**503.1.1 Buildings and facilities.** *Approved* fire apparatus access roads shall be provided for every facility, building or portion of a building hereafter constructed or moved into or within the jurisdiction. The fire apparatus access road shall comply with the requirements of this section and shall extend to within 150 feet (45 720 mm) of all portions of the facility and all portions of the exterior walls of the first story of the building as measured by an approved route around the exterior of the building or facility. In sprinklered Group R-2 apartment houses, the distance may be measured through open breezeways having a minimum clear width of six feet.

**Exceptions:**

1. The fire code official is authorized to increase the dimension of 150 feet (45 720 mm) where any of the following conditions occur:
  - a. The building is equipped throughout with an *approved automatic sprinkler system* installed in accordance with Section 903.3.1.1, 903.3.1.2 or 903.3.1.3. The dimension shall be increased from 150 feet to 200 feet. This increase shall not be applicable to Groups H and I Occupancies, buildings with occupancies having High-Piled Combustible Storage and high-rise buildings.
  - b. Fire apparatus access roads cannot be installed because of location on property, topography, waterways, nonnegotiable grades or other similar conditions, and an *approved* alternative means of fire protection is provided.
  - c. There are not more than two Group R-3 or Group U occupancies.
  - d. The building is a non-combustible Group S-2 open parking garage meeting the requirements of the 2015 International Building Code Section 406.3, with or without a sprinkler system. The increase shall be allowed to be up to 200 feet.
2. Where approved by the fire code official, fire apparatus access roads shall be permitted to be exempted or modified for solar photovoltaic power generation facilities.

*Section 503.1.1 Buildings and facilities is amended by adding Section 503.1.1.1 Access from adjacent lot as follows:*

**503.1.1.1 Access from adjacent lot.** Where fire apparatus access roads for a building or buildings are provided from an adjacent lot, a fire lane easement or ingress/egress easement is required to be recorded on the adjacent lot's plat that is providing the common access. The adjacent lot's plat is to clearly show the easement graphically.

**Exception:** In lieu of the graphical easement, a note may be placed on the plat that, at a minimum, states, the following: "Ingress and egress shall be provided between all adjacent lots for adequate fire department vehicle access per the City

of San Antonio Fire Code. The cross access shall not be blocked nor may this note be taken off the plat without written permission from the City of San Antonio Director of Development Services and the San Antonio Fire Department Fire Marshal."

*Section 503.2.1 Dimensions is amended by adding Sections 503.2.1.1 Divided Entrance to Property and 503.2.1.2 Mountable Curbs to read as follows:*

**503.2.1.1 Divided Entrance to Property.** When guard houses, security stations, median, landscape islands or other similar use obstructions are so located as to create a one-way and partially obstruct the entrance(s) to a property or fire lane(s) in any location, such one - way(s) shall be a minimum of fourteen feet clear on each side of the obstruction. This minimum requirement is only applicable at the point(s) of obstruction and is not permitted along required Aerial Apparatus Access Roads, Fire Apparatus Access Roads adjacent to fire hydrants or fire department connections or at any location where a Fire Apparatus Vehicle is expected to be positioned for the duration of the fire event. Turning radii shall be permitted in Section 503.2.4.

**503.2.1.2 Mountable Curbs.** Mountable curbs are permitted when approved by the Fire Marshal.

*Section 503.2.3 Surface is amended by adding a second paragraph to read as follows:*

**503.2.3 Surface.** Fire apparatus access roads shall be designed and maintained to support the imposed loads of fire apparatus and shall be surfaced so as to provide all-weather driving capabilities.

Drivable grass surfaces, or other alternative drivable surfaces, are permitted when approved by the Fire Marshal or his designee and in accordance with all of the following conditions:

1. Sealed documents indicating compliance with the provisions of 503.2.3 shall be submitted by a registered design professional for review.
2. The drivable grass surface, or alternative drivable surface, shall not be used as the primary access to the site.
3. The surface shall be capable of supporting the imposed load of fire apparatus weighing at least 75,000 pounds.
4. Blue traffic reflectors shall be provided on each side of the surface every 20 feet to clearly mark its boundaries. Vegetation on and surrounding the surface shall be maintained such that said reflectors are visible at all times.
5. Sod is not permitted to be placed over the drivable base.
6. If the surface proposed is to be used as the aerial apparatus access road for the facility, concrete curbing, or other approved edging, shall be installed along both sides of the portion to be used as such for enhanced lateral stability.

7. If sand or other free-flowing fill is used as a main structural component for the surface, concrete curbing or other approved edging shall be installed along both sides of the surface for material containment.
8. The surface shall be maintained in proper working order at all times when utilized as a required fire lane. Should the surface become damaged or fall into disrepair, the Fire Marshal or his designee shall be authorized to require the repair and re-certification of said surface.

*Section 503.2.4 Turning radius is amended by adding a second paragraph to read as follows:*

**503.2.4 Turning radius.** The required turning radius of a fire apparatus access road shall be determined by the *fire code official*.

The turning radii of a fire apparatus access roadway shall require a minimum of 50 feet outside radius and a minimum of 25 feet clear distance to the inside radius on all turns in excess of 30 degrees.

*Section 503.2.5 Dead Ends is amended to read as follows:*

**503.2.5 Dead Ends.** Dead-end fire apparatus access roads in excess of 150 feet [~~(45-720 mm)~~] in length shall be provided with [~~an~~] approved [~~area~~] provisions for the turning around of fire apparatus. Turn arounds approved by the Fire Marshal or as permitted by Appendix D are acceptable.

**Exception:** Where the building is equipped throughout with an approved sprinkler system in accordance with Section 903.3.1.1, 903.3.1.2, or 903.3.1.3, the maximum length of dead-end fire apparatus access roads shall be increased to 200 feet. This increase shall not be applicable to Groups H and I Occupancies, buildings with occupancies having High-Piled Combustible Storage and high-rise buildings. This increase shall apply to all non-combustible Group S-2 open parking garages meeting the requirements of the 2015 International Building Code Section 406.3, with or without a sprinkler system.

*Section 503.2.7 Grade is amended to read as follows:*

**503.2.7 Grade.** The gradient for a fire apparatus access road shall not exceed 12%. [~~The grade of the fire apparatus access road shall be within the limits established by the fire code official based on the fire department's apparatus.~~]

*Section 503.3 Marking is amended to read as follows:*

**503.3 Marking.** Upon the designation of a fire lane pursuant to this ordinance, the Fire Marshal shall give notice of such designation to the owner of such designated premise, directing the owner to cause signs to be posted at the expense of the owner at designated locations stating: "Fire Lane - No Parking at any Time City Ord. 54547." Such signs shall be of standard size and color, of standard lettering

and mounting, conforming to specifications established by the Director of Public Works. In addition to the signs, the owners of such designated premises at their option, or, if so directed by the Fire Marshal, shall paint all fire lane curbs red with white-stenciled letters stating "Fire Lane, No Parking." Lettering for the curbs shall use 4 inch lettering with a distance of not more than 40 feet between wording. It shall be unlawful to park any vehicle other than an authorized emergency vehicle in a designated fire lane when such signs are in place or such red curbing exists. In areas where the fire lane may not be clearly defined, the Fire Marshal may require a four inch red stripe be painted that defines the boundaries of the fire lane. [Where required by the fire code official, approved signs or other approved notices or markings that include the words NO PARKING — FIRE LANE shall be provided for fire apparatus access roads to identify such roads or prohibit the obstruction thereof. The means by which fire lanes are designated shall be maintained in a clean and legible condition at all times and be replaced or repaired when necessary to provide adequate visibility.]

*Section 503.4.1 Traffic calming devices is hereby deleted.*

~~[503.4.1. Traffic calming devices. Traffic calming devices shall be prohibited unless approved by the fire code official.]~~

*Section 503.6 Security gates is hereby amended by adding the following language and adding a new Section 503.6.1 Direction of Swing to read as follows:*

**503.6 Security gates.** The installation of security gates across a fire apparatus access road shall be *approved* by the fire chief. Where security gates are installed, they shall have an *approved* means of emergency operation to include a fire department specific key switch, lock, or box. Upon loss of power to electric gate operators, a secondary power source or clearly marked and identified manual release shall be provided. The security gates and the emergency operation shall be maintained operational at all times. Electric gate operators, where provided, shall be listed in accordance with UL 325. Gates intended for automatic operation shall be designed, constructed and installed to comply with the requirements of ASTM F 2200.

**503.6.1 Direction of Swing.** Security gates installed across a Fire Apparatus Access Road shall swing in the direction of travel towards the building or open horizontally to avoid backing up of Fire Apparatus and to allow for an expedited response.

*SECTION 503 FIRE APPARATUS ACCESS ROADS is amended by adding Sections 503.7 Fire Marshal Authority to Designate Fire Lanes, 503.8 Summons to be Issued for Parking Violation, 503.9 Removal of Vehicle by Property Owner, 503.10 Removal of Vehicle by Fire Chief, and 503.11 Abandonment of Fire Lane to read as follows:*

**503.7 Fire Marshal Authority to Designate Fire Lanes.** The Fire Marshal is hereby authorized to designate fire lanes on designated premises where such areas must be free of parked vehicles and other obstructions to provide ready access to buildings therein, in case of fire or other emergencies. The Fire Marshal's designation of such fire lanes does not obviate the owner of such property of their responsibility to maintain the area. Further, owners of the private property or their designated representative may request that additional fire lanes be designated by the Fire Marshal.

**503.8 Summons to be Issued for Parking Violation.** A summons or notice to appear in answer to a charge of parking in violation of this section specifying the location of the fire lane in which such violation occurred and the date and time of such violation, may be issued by any police officer or any member of the Arson Investigating unit or inspectors in the Fire Prevention Bureau of the Fire Department.

**503.9 Removal of Vehicle by Property Owner.** Except an authorized emergency vehicle, the owner of private property, or their agent, may have any motor vehicle that is parked in a legally designated fire lane removed and stored at either their own expense or that of the vehicle operator.

The owner of the premises, or their agent, who has a vehicle removed and stored, is not liable for damages incurred as a result of removal or storage, if the vehicle is removed by a vehicle wrecker service insured against liability for property damage incurred in towing vehicles and is stored by a storage company insured against liability for property damage incurred in the storage of vehicles.

**503.10 Removal of Vehicle by Fire Chief.** Any vehicle parked in any designated fire lane may be removed at the vehicle owners' expense upon the authorization of the Fire Chief under the following conditions:

1. When the vehicle violates Ordinance number 54547 (the fire lane Ordinance) by parking in a fire lane, or
2. When a vehicle blocks the ingress/egress of a business, theater, night club, apartment complex, gymnasium or a place of assembly, or
3. When a vehicle's presence threatens the life safety of the public by impeding the ability of the fire apparatus and emergency medical equipment to respond to an emergency.

The Fire Chief shall cause such vehicle to be removed by the towing service operating under a contract with the city and shall further cause such vehicle to be impounded in one of the Police Department Vehicle Storage sections.



**503.11 Abandonment of Fire Lane.** No owner, manager or person in charge of any premises served by a required fire lane shall abandon or close any such fire lane without the written permission of the Fire Marshal.

*Section 505.1 Address Numbers is amended to read as follows:*

**505.1 Address identification.** New and existing buildings shall have approved address numbers, building numbers or [be provided with] approved building [address]\_identification. The address identification shall be legible and placed in a position that is visible from the street or road fronting the property. Address identification characters shall contrast with their background. Address numbers shall be Arabic numbers or alphabetical letters. Numbers shall not be spelled out. Address characters shall be a minimum of 6 inches (102 mm) high with a minimum stroke width of 0.5 inch (12.7 mm). For buildings with individual suites, the suite numbers shall be a minimum of 4 inches high with a minimum stroke width of 0.5 inches. [~~Each character shall be not less than 4 inches (102 mm) high with a minimum stroke width of ½ inch (12.7 mm).~~] Where required by the *fire code official*, address identification shall be provided in additional *approved* locations to facilitate emergency response. Where access is by means of a private road and the building cannot be viewed from the *public way*, a monument, pole or other sign or means shall be used to identify the structure. Address numbers shall be maintained.

*SECTION 505 PREMISES IDENTIFICATION is amended to add sections 505.3, 505.3.1, 505.4, and 505.5 as follows:*

**505.3 Multi-Building Complexes.** Office, industrial and apartment complexes shall be identified by name and number on a display board at the main entry roadway.

**505.3.1 Multi-Address Complexes.** Office and industrial complexes with multiple addresses contained within shall post all addresses so that they are visible from roadway.

**505.4 Mall Lease Spaces.** Each mall lease space shall be identified by a uniform size number at a uniform easily visible location in proximity to exterior and mall entrance doors.

**505.5 Tenant identification.** Each occupied tenant space provided with a secondary exit to the exterior or exit *corridor* shall be provided with tenant identification by business name and~~/or~~ address. Letters and numbers shall be posted on the *corridor* side of the door, be plainly legible and shall contrast with their background.

**Exception:** Tenant identification is not required for anchor stores.

*SECTION 506 KEY BOXES, is amended to add Sections 506.2.1 Key Box Access and Removal of Keys and 506.3 Key Box Location and Contents as follows:*

**506.2.1 Key Box Access and Removal of Keys.** The Fire Department shall have the only key to the key box. Removal of any key by other than the authorized Fire Department personnel shall be a violation of this Code.

**506.3 Key Box Location and Contents.** Required key boxes shall be located as follows and as approved by the Fire Marshal:

1. Within 12 feet of the emergency elevators and visible from the entrance to the emergency elevator; or
2. Between eight feet and 10 feet to the side of the main entrance level to the building and between eight to 10 feet from the grade where practical, or as approved by the Fire Marshal.

The key box shall contain designated keys essential to emergency operations including, but not limited to, the following:

1. Elevator keys capable of accessing all floors in the building
2. Stairway keys
3. Fire control station keys
4. Alarm System keys

*Section 507.3 Fire flow, is amended to read as follows and Section 507.3.1 Fire Flow for Rural Isolated Areas is added to read as follows:*

**507.3 Fire flow.** Fire Flow requirements for buildings or portions of buildings and facilities shall be as per Appendix B of the International Fire Code or other ~~determined by an~~ approved method as determined by the Fire Marshal. When utilizing Table C105.1 to determine number and distribution of fire hydrants, and the flow requirement falls between the values on the table, the flow requirement shall be rounded up to meet the higher value.

**507.3.1 Fire Flow for Rural Isolated Areas.** The fire flow requirements for rural, isolated structures may be determined as follows: The Fire Marshal may modify the fire flow requirements for small isolated buildings or light hazard occupancies (as defined in the Edition of NFPA 13 referenced in Chapter 80) under the following conditions:

1. The building is fully protected with an approved automatic fire sprinkler system installed in accordance with Section 903.3.1.1 or 903.3.1.2;

2. The automatic sprinkler system demand, including hose stream demand is provided;
3. The building is located in a subdivision area considered by the Code Official to be in a rural setting;
4. Provision of a fully compliant water supply is a severe economic burden;
5. A minimum of 60 foot yard is provided between the buildings and property lines (dedicated right-of-way may be used to obtain clear distance); and
6. When the Fire Code required fire flow is available at the property line, the owner shall connect to the water supply system and provide on-site fire hydrants and water supply as is otherwise required by the Code.

*Section 507.4 Water supply test is amended to read as follows:*

**507.4 Water supply test.** Adequacy of the water supply shall be determined by an approved flow test that is conducted on the fire hydrants nearest the project site unless otherwise approved by the Code Official. The flow test shall be as follows: ~~[The fire code official shall be notified prior to the water supply test. Water supply tests shall be witnessed by the fire code official or approved documentation of the test shall be provided to the fire code official prior to final approval of the water supply system.]~~

1. The flow test shall have been conducted no more than 12 months prior to the date of construction document submittal to the City of San Antonio.
2. The flow test shall be conducted in accordance with the 2010 edition of NFPA 291, Recommended Practice for Fire Flow Testing and Marking of Hydrants, and any other applicable local, state, or national standards and/or requirements.
3. The flow test results shall be submitted with the construction documents in accordance with the COSA standard fire flow test format.
4. If the water supply piping is not yet constructed, hydraulic calculations for the proposed piping design shall be submitted. The calculations shall be based on the flow test conducted on the fire hydrants nearest the project site and shall verify that the piping design provides the minimum require fire flow at no less than 25 psi residual. Upon

completion of construction and prior to final certificate of occupancy, a flow test shall be conducted to verify the results of the calculations.

*Section 507.5.1 Where Required is amended to read as follows:*

**507.5.1 Where Required.** Public and/or private fire hydrants are required to be installed where one or more of the following conditions exist:

1. Existing fire hydrants do not meet the required fire hydrant location and spacing criteria defined in Section 507.5.1.1, 507.5.1.2, or Appendix C.
2. The complexity of the project justifies their installation as determined by the Fire Marshal.

~~[Where a portion of the facility of building hereafter constructed or moved into or within the jurisdiction is more than 400 feet (122 m) from a hydrant on a fire apparatus access road, as measured by an approved route around the exterior of the facility or building, on-site fire hydrants and mains shall be provided where required by the fire code official.]~~

~~[Exceptions:~~

- ~~1. For Group R-3 and Group U occupancies, the distance requirement shall be 600 feet (183 m).~~
- ~~2. For buildings equipped throughout with an approved automatic sprinkler system installed in accordance with Section 903.3.1.1 or 903.3.1.2, the distance requirement shall be 600 feet (183 m).]~~

*Section 507.5.1.1 Hydrant for standpipe systems is deleted and replaced with Section 507.5.1.1 Fire Hydrant Location and Spacing for Non-Single Family Developments:*

**507.5.1.1 Fire Hydrant Location and Spacing for Non-Single Family Developments.** Sufficient fire hydrants shall be considered to be provided for a building when:

1. Not more than 500 feet of hose will be required to reach from a fire hydrant to all exterior portions of the first floor of the structures in question; and

**Exception:** Where the building is equipped throughout with an approved sprinkler system installed in accordance with Section 903.3.1.1, 903.3.1.2, or 903.3.1.3, the maximum distance from hydrants to all exterior portions of the building shall be increased to 750 feet as the hose lays. This increase shall not be applicable to Groups H and I Occupancies, buildings with occupancies having

High-Piled Combustible Storage and high-rise buildings. This increase shall apply to all non-combustible Group S-2 open parking garages meeting the requirements of the 2012 International Building Code, Section 406.3, with or without a sprinkler system.

2. All fire hydrants required as prescribed by Appendix C shall be within 500 feet of a point on the building being protected and said distance is measured per the hose lay criteria in Section 507.5.1.2.

**Exception:** Where the building is equipped throughout with an approved sprinkler system installed in accordance with Section 903.3.1.1, 903.3.1.2, or 903.3.1.3, the maximum distance from hydrants to a point on the building shall be increased to 750 feet as the hose lays. This increase shall not be applicable to Groups H and I Occupancies, buildings with occupancies having High-Piled Combustible Storage and high-rise buildings. This increase shall apply to all non-combustible Group S-2 open parking garages meeting the requirements of the 2012 International Building Code Section 406.3, with or without a sprinkler system.

~~[507.5.1.1 Hydrant for standpipe systems. Buildings equipped with a standpipe system installed in accordance with Section 905 shall have a fire hydrant within 100 feet (30 480 mm) of the fire department connections.~~

~~**Exception:** The distance shall be permitted to exceed 100 feet (30 480 mm) where approved by the fire code official.]~~

*Section 507.5.1 Where required is amended by adding Section 507.5.1.2 Fire Hydrant Location and Spacing:*

**507.5.1.2 Fire Hydrant Location and Spacing.** Fire hydrants shall be located and spaced per the following criteria:

1. Hose lay is measured along public streets, fire lanes, and access roadways for Fire Department vehicles. This hose lay consists of 350 feet of supply line as deployed by truck, and 150 feet of hose deployed by hand. Unless otherwise increased in this Code, where the building is equipped throughout with an approved sprinkler system installed in accordance with Section 903.3.1.1, 903.3.1.2, or 903.3.1.3, the maximum distance from hydrants to a point on the building shall be increased to 750 feet as the hose lays with 550 foot hose lay by the truck and 200 foot hose lay by hand.
2. No fire flow credit is allowed for hydrants which are so obstructed as to make their use impractical, such as, but not limited to, hydrants across main line railroad tracks that are in heavy use or across limited access highway, expressways, primary thoroughfares, across streams, or walls.

3. Hydrants required by this code along both public and private water mains shall be spaced no closer than 300 feet with spacing between hydrants not to exceed 600 feet. Additional non-required hydrants may be spaced no closer than 200 feet from required hydrants unless approved by the fire code official.
4. Fire hydrants shall be located along the public right-of-way or along the Fire Department access roadways, preferably at intersections or on islands separating parking areas which cannot be obstructed by parked vehicles. Hydrants in areas subject to physical damage shall be protected from collision. Fire hydrants across more than four lanes of traffic (including turning lanes) or across medians are not considered accessible.
5. Where existing or proposed fire line(s) and/or existing or proposed fire hydrant(s) are to be used to meet the requirements of this Code and are provided from an adjacent lot, said appurtenances shall be provided with a dedicated water easement. The easement is required to be recorded on the adjacent lot's plat that is proposing the shared access. The adjacent lot's plat is to clearly show the water easement graphically. Recordation by legal instrument alone is not approved by the Fire Marshal.

*Section 507.5.3 Private fire service mains and water tanks is amended by adding Section 507.5.3.1 Private fire service main as follows:*

**507.5.3.1 Private Fire Service Main.** Private fire mains as used in this Code are the pipe and its appurtenances on private property between San Antonio Water System, other public water system, or other sources of water and the base elbow of private fire hydrants or the rise for automatic sprinkler or standpipe systems. When connected to a public water system, the private fire main begins at a point designated by the public water utility. When connected to a gravity tank or pressure tank, the private fire main begins at the inlet side of the tank check valve.

*Section 507.5.5 Clear spaces around hydrants is amended to read as follows:*

**507.5.5 Clear space around hydrants.** A 3-foot (914 mm) clear space shall be maintained around the circumference of fire hydrants, except as otherwise required or *approved*. The clear space around hydrant and the access to the hydrant will be no more than eight percent slope.

*Section 507.5 Fire Hydrant Systems is amended by adding Sections 507.5.7 Design Criteria for Water Mains and 507.5.8 Fire Hydrant Installation Criteria as follows:*

**507.5.7 Design Criteria for Water Mains.**

1. Where the fire service mains are used to supply required fire hydrants, the mains shall be sized to flow the required fire flow as determined by Section 507.3.

2. Where the fire service mains are used to supply required fire hydrants plus fire sprinkler and/or fire standpipe systems, the mains shall be sized to flow the larger of the fire hydrant flow demand as determined by Section 507.3, the fire sprinkler demand as determined by Section 903.3 or the fire standpipe demand as determined by Section 905.2.
3. The required number of fire hydrants for the fire flow determined by Section 507.3 shall be specified in Appendix C, Table C105.1.
4. When sizing the fire service main, the distribution of the fire flow among the required fire hydrants (as determined by item no. 1 or 2 above) shall be as determined by the Fire Marshal, but in most cases shall have no less than 1,000 gpm at the hydraulically remote fire hydrant with the remaining fire flow equally distributed among the remaining required fire hydrants.
5. Main Size:
  - 5.1 Minimum diameter for public water mains shall be six inches in single-family residential areas and eight inches in all other areas. Larger mains may be required to accommodate fire flow requirements.
  - 5.2 Private fire mains shall be hydraulically calculated.
6. Water pressure in private fire mains shall not be less than thirty-five pounds per square inch (35 psi) with no hydrants in use. When hydrants are in use supplying the required fire flow, water pressure in the main at the fire hydrant discharge level shall be not less than 25 pounds per square inch (25 psi) residual.
7. Except for specific requirements of this code, all hydrants and mains required for private protection shall be designed, constructed, and operated in conformance with the local water purveyor's criteria, specifications and regulations for public fire hydrants and mains on public streets and NFPA 24.

**507.5.8 Fire Hydrant Installation Criteria.** Fire hydrants shall be installed per the following criteria:

1. Fire hydrants shall be a minimum of one foot and a maximum of seven feet from the gutter face of the curb which forms a public way or Fire Lane. Fire hydrants in parking lots adjacent to a Fire Lane or public way shall meet the same requirement for distance and be located on a curbed island or protected by bollards.

2. The steamer (pumper) connection shall be a minimum of one and one-half feet and a maximum of two feet above grade.
3. All private hydrants shall be painted red.
4. Fire hydrants shall be right turn only.
5. The steamer (pumper) connection shall face the street, fire access road or fire lane.
6. The steamer (pumper) connection shall have a nominal inside diameter of 4 inches.
7. Hydrants shall have two other hose connections with a nominal inside diameter of 2.5 inches in addition to the steamer (pumper) connection.
8. Hydrants, public or private, shall be located not less than 40 feet from the building to be protected.

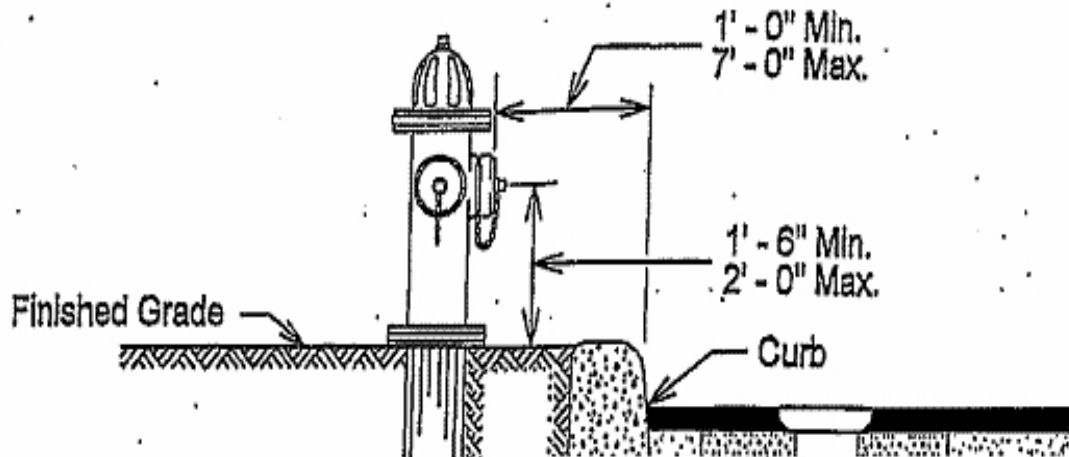

*SECTION 510 EMERGENCY RESPONDER RADIO COVERAGE is hereby repealed and replaced with a new SECTION 510 EMERGENCY RESPONDER RADIO COVERAGE as follows:*

**SECTION 510**  
**EMERGENCY RESPONDER RADIO COVERAGE**

**510.1 Radio Coverage.** Except as otherwise provided, no person shall erect, construct, or modify any building or structure or any part thereof, or cause the same to be done which fails to support adequate radio coverage for City of San Antonio public safety services including, but not limited to, police, fire, and



public works departments. A certificate of occupancy may not be issued for any building or structure which fails to comply with this requirement.

The frequency range which must be supported shall be 800 MHz range or as otherwise established and required in writing by the City of San Antonio as being necessary for public safety purposes.

For the purposes of this code, adequate radio coverage shall include a minimum signal level of DAQ 3 (Delivered Audio Quality #) available in 95% of the area as agreed to be in the coverage acceptable test plan by the City of San Antonio and the radio system manufacturer prior to system testing.

**510.2 Amplification System allowed.** Buildings and structures shall be equipped with any of the following in order to achieve adequate radio coverage:

1. A radiating cable system;
2. An internal multiple system with FCC Type Accepted Bi-Directional UHF Amplifiers as needed to encompass the frequency range stated above or frequency range subsequently established by the city; or
3. A system that has been approved by the City of San Antonio as being capable of providing amplification to meet this code requirement.

The system shall be capable of operating on an independent battery and/or generator system for a period of at least 12 hours without external power input. The battery system shall automatically charge in the presence of external power input. There shall be no connectivity between the amplification system and fire alarm system.

**510.3 Owner Responsibility.** It shall be the responsibility of the owner of a building or structure which currently holds a certificate of occupancy or allows the building or structure to be used for any purpose other than construction to be in compliance with this chapter upon its effective date.

**510.4 Inadequate Radio Coverage.** Any building or structure which fails to support adequate radio coverage must have a plan acceptable to the San Antonio Fire Department within 90 days by the owner or their agent to address the inadequate radio coverage.

**510.5 Acceptance Test Procedures.** Acceptance testing for an in-building radio amplification system is required upon completion of installation of the system. It is the building owner's responsibility to have the radio system tested to ensure that two-way coverage on each floor of the building is a minimum of DAQ 3. Testing will be accomplished by a licensed third party contractor.

Each floor of the building shall be divided into a grid of approximately forty equal areas. A maximum of two nonadjacent areas will be allowed to fail the test. In the event that three of the areas fail the test, in order to be more statistically accurate, the floor may be divided into eighty equal areas. In such event, a maximum of four non-adjacent areas will be allowed to fail the test. After the eighty area tests, if the system continues to fail, the building owner shall repair, replace, alter, or upgrade the system altered to meet the DAQ 3 coverage requirement. Talk back testing from site to the San Antonio Fire Department Dispatch Center shall use a two watt portable transceiver with speaker/microphone and flexible antenna. A spot located approximately in the center of a grid area will be selected for the test, then the radio will be keyed to verify two-way communication to and from the outside of the building. Once the spot has been selected, use of another spot within the grid area will not be permitted. Field strength testing instruments are to be of the frequency selective type incorporating a flexible antenna similar to the ones used on the hand held transceivers and also recently calibrated (within 12 months).

The gain values of all amplifiers shall be measured and the results kept on file with the building owner so that the measurements can be verified each year during the annual tests. In the event that the measurement results become lost, the building owner will be required to rerun the acceptance test to reestablish the gain values.

**510.6 Annual tests.** When an in-building radio system is installed, the building owner shall test all active components of the system including, but not limited to, the amplifier, the power supplies, and back-up batteries, a minimum of once every 12 months. Amplifiers shall be tested to ensure that the gain is the same as it was upon initial installations and acceptance. Back-up batteries and power supplies shall be tested under load for a period of one hour to verify that they will operate during an actual power outage. All other active components shall be checked to determine that they are operating within the manufacturers' specifications for the intended purpose.

**510.7 Five Year Test.** In addition to the annual test, the building owner shall perform a radio coverage test a minimum of once every five years to ensure that the radio system continues to meet the requirements of the original acceptance. The procedure set forth above shall apply to such tests.

**510.8 Qualifications of testing personnel.** All tests shall be conducted, documented, and signed by a person in possession of a current FCC general radiotelephone operator license. All test records shall be retained at the inspected premise by the building owner and a copy submitted to the San Antonio Fire Department within 30 days of when the test has been conducted. In the event the test shall fail to comply with the minimum requirements of the City, appropriate repairs shall be made and additional tests conducted until tests meet the minimum requirements of the City. Proof of current license shall be submitted along with third party testing.

**510.9 Inspections.** City personnel, after providing reasonable notice to the owner or their representative, shall have the right to enter onto the property to conduct field testing to be certain that the required level of radio coverage is present.

**510.10 Property owner maintenance responsibilities.** Upon completion of all tests to the minimum standards of the City, the property owner shall be responsible for maintenance of the system. A maintenance contract shall be provided to the San Antonio Fire Department with the name of the contractor, who will supply a 24-hour, seven-day emergency response within two hours after notification by either the City or property owner. The maintenance contract shall also contain information as to contact personnel with phone numbers. Property owners shall also submit information to the San Antonio Fire Department as to contact personnel with phone numbers for the property owner.

The property owner shall also be responsible for making any repairs, replacement or upgrades to the systems as directed by the San Antonio Fire Department, should the system fail or no longer work in the future.

**510.11 Exemptions.** This section shall not apply to buildings less than 50,000 square feet or any single-family detached residential dwelling or multifamily building or structure less than 50,000 square feet or any building under four stories with less than 50,000 square feet per floor.

**510.12 Failure to comply.** Failure to comply with this code shall be grounds for the Director of Development Services to revoke any previously issued Certificate of Occupancy for the building or structure. A written appeal may be taken to the Building-related and Fire Codes Appeals and Advisory Board regarding the revocation of the Certificate of Occupancy. A further appeal may be taken to the Mayor and City Council within seven days of the decision of the Building-related and Fire Codes Appeals and Advisory Board by filing a petition with the City Clerk.

**Section 604.1 Installation is amended by adding Section 604.1.9 Natural gas generators and Section 604.1.10 Diesel fueled generators fuel tank venting as follows:**

**604.1.9 Natural gas generators.** Natural gas generators shall be allowed to be used as an emergency or standby power source for emergency life safety equipment only when all of the following conditions are met:

1. The natural gas line supplying the generator must have a separate shutoff that is not affected by turning off the supply line to the building.
2. The shutoff for the natural gas line supplying the generator must have a sign at the shutoff that reads: "EMERGENCY GENERATOR GAS LINE, SHUT DOWN THIS LINE ONLY FOR EMERGENCIES INVOLVING EMERGENCY GENERATOR."

3. The generator must be a minimum of 10 feet from any building opening.
4. The installation of all natural gas generators shall be required to meet the provisions of the 2015 International Plumbing Code and the 2014 National Electrical Code.

**604.1.10 Diesel fueled generator fuel tank venting.** Fuel tanks associated with diesel fueled generators shall be vented in accordance with Section 5704.2.7.3.3

*Section 610 COMMERCIAL KITCHEN COOKING OIL STORAGE is hereby repealed.*

*SECTION 806 DECORATIVE VEGETATION IN NEW AND EXISTING BUILDINGS is amended by adding a new Section 806.6 Length of Display as follows:*

**806.6 Length of Display.** No cut natural Christmas tree shall be displayed in a non-residential occupancy for more than 15 days from the date of purchase.

*Section 807.2 Acceptance criteria and reports is amended by adding Section 807.2.1 Flameproof Testing by Fire Marshall as follows:*

**807.2.1 Flameproof Testing by Fire Marshal.** The Fire Marshal may test decorative materials to determine if they are adequately flameproof.

*Section 901.4 Installation is amended by adding Section 901.4.7 Fire Mains as follows:*

**901.4.7 Fire Mains.** Fire service mains bedding, backfill/initial backfilling for concrete steel cylinder pipe (CSC), ductile iron pipe (DI), and polyvinyl chloride pipe (PVC) in all nominal diameters shall be composed of sand, well graded crushed stone or gravel conforming to the following requirements unless modified by the engineer:

<u>MODIFIED</u> <u>GRADE 5</u>	<u>PERCENT</u>
<u>Retained on</u> <u>1/2" sieve</u>	<u>0%</u>
<u>Retained on</u> <u>3/8" sieve</u>	<u>0—5%</u>
<u>Retained on</u> <u>No. 4 sieve</u>	<u>20—80%</u>
<u>Retained on</u> <u>No. 10 sieve</u>	<u>75—100%</u>

Retained on	98—100%
No. 20 sieve	

The backfill shall be installed prior to the inspection with the joints left exposed.

*Section 901.5 Installation Acceptance Testing is hereby amended to read as follows:*

**901.5 Installation Acceptance Testing.** Fire detection and alarm systems, fire-extinguishing systems, fire hydrant systems, fire standpipe systems, fire pump systems, private fire service mains and all other *fire protection systems* and appurtenances thereto shall be subject to acceptance tests as contained in the installation standards and as *approved* by the *fire code official*. The fire code official shall be notified before any required acceptance testing. A representative of the Fire Marshal shall witness all required acceptance tests for all these systems.

*Section 901.6 Inspection, testing and maintenance is amended by adding Section 901.6.3 Maintenance Agreement as follows:*

**901.6.3 Maintenance Agreement.** A maintenance agreement, as defined by Section 202, with a licensed fire protection company shall be provided to the Fire Marshal for each fire protection system at all times. Proof of a maintenance agreement shall be provided during any system acceptance test. Agreements for testing and inspection only as defined by Section 202 shall not be credited with having met this requirement.

*Section 901.7 Systems out of service is hereby amended to read as follows:*

**901.7 Systems out of service.** Where a required *fire protection system* is out of service, the fire department and the *fire code official* shall be notified immediately and, where required by the *fire code official*, the building shall either be evacuated or an *approved* fire watch shall be provided for all occupants left unprotected by the shutdown until the *fire protection system* has been returned to service.

A fire watch will be performed at all times that a system is taken out of service. Except for emergencies, the *fire code official* shall be given 72 hours notice before a system is voluntarily taken out of service. When, at the discretion of the Fire Chief or his designee, there is a life safety issue, uniformed employees of the San Antonio Fire Department or other fire watch personnel as *approved* by the Fire Chief or his designee shall perform a fire watch. Fire watch personnel shall be provided with at least one approved means for notification to the fire department dispatch and their sole duty shall be to perform constant patrols and watch for safety hazards and occurrences of fire. The cost of the fire watch shall

be at the current overtime rate for fire inspections and shall be the sole responsibility of the owner/contractor to pay. The fire watch fee shall be paid to the City of San Antonio before final approval is granted on system work. [Where utilized, fire watches shall be provided with at least one approved means for notification of the fire department and their only duty shall be to perform constant patrols of the protected premises and keep watch for fires.]

*Section 902.1 Definitions is hereby amended by adding a definition for "Porte Cochere."*

**902.1 Definitions.** The following words and terms shall, for the purposes of this chapter and as used elsewhere in this code, have the meanings shown herein.

**PORTE COCHERE.** A roofed structure that is open on at least three sides and extends from the building entrance over an adjacent driveway and shelters vehicle ingress and egress.

*Section 903.1 General is amended by adding Section 903.1.2 Safety factor and Section 903.1.3 High Volume Low Speed Fans in new and existing buildings as follows:*

**903.1.2 Safety factor.** Automatic sprinkler systems shall be designed with a minimum of 10% or five psi safety factor (whichever is greater) taken at the base of the riser for the hydraulically most demanding design area.

**903.1.3 High volume low speed fans in new and existing buildings.** The use of High Volume Low Speed (HVLS) or High Volume Low Velocity (HVLV) fans in fire sprinklered areas of new and existing buildings shall only be permitted as follows:

1. HVLS fans are permitted in rack storage and palletized storage arrangements up to twenty (20) feet in height in buildings with thirty (30) feet or less ceiling clearance, when Early Suppression Fast Response (ESFR) sprinklers are used to protect the storage array.
2. HVLS fans are permitted in light-hazard and ordinary-hazard occupancies as defined in NFPA 13, *Standard for the Installation of Sprinkler Systems*.
3. HVLS fans are not permitted in sprinklered areas with palletized storage greater than twelve (12) feet in height protected by control mode sprinklers.
4. In all cases, HVLS fans are required to be designed and installed to shut down automatically on any fire alarm signal. This includes automatic shut down upon sprinkler system waterflow alarm or any manual or automatic fire alarm detection device provided in the space.

5. In all cases, the clearance between the HVLS fans and the ceiling sprinklers and the top of storage shall be in compliance with the obstruction and clearance rules of NFPA 13.

**Exception:** When a technical opinion and report is provided in accordance with Section 104.7.2, the Fire Marshal or his designee shall analyze the opinion and report and may approve the use of HVLS or HVLV fans in additional areas when it is determined that the effectiveness of the fire sprinkler system is not compromised.

*Section 903.2.1 Group A is hereby amended by adding the following exception:*

**903.2.1 Group A.** *An automatic sprinkler system shall be provided throughout buildings and portions thereof used as Group A occupancies as provided in this section. For Group A-1, A-2, A-3 and A-4 occupancies, the automatic sprinkler system shall be provided throughout the story where the fire area containing the Group A-1, A-2, A-3 or A-4 occupancy is located, and throughout all stories from the Group A occupancy to, and including, the levels of exit discharge serving the Group A occupancy. For Group A-5 occupancies, the automatic sprinkler system shall be provided in the spaces indicated in Section 903.2.1.5.*

**Exception:** A one-story detached open pavilion consisting of a only a roof and supporting columns that meets all of the following criteria shall not require fire sprinklers.

1. The detached open pavilion is a Group A2, Group A3 or Group A4 Occupancy.
2. The detached open pavilion shall be less than 12,000 ft<sup>2</sup> in area.
3. The detached open pavilion shall be separated from adjacent structures by minimum of 30 feet.
4. The detached open pavilion is open on at least three sides and open a minimum of 50% of the perimeter of the area covered. In order to be considered "open" for the purpose of this exception, an open side shall be at least 50% open with the open area uniformly distributed to prevent the accumulation of smoke and toxic gases.
5. The detached open pavilion shall have a minimum of 300% of the total number of required exits and a minimum of 300% of total exit minimum width or required capacity based upon the occupant load of the pavilion.

*Section 903.2.1.3 Group A-3 is hereby amended to add a fourth condition to read as follows:*

**903.2.1.3 Group A-3.** An automatic sprinkler system shall be provided for *fire areas* containing Group A-3 occupancies and intervening floors of the building where one of the following conditions exists:

1. The *fire area* exceeds 12,000 square feet (1115 m<sup>2</sup>).
2. The fire area has an *occupant load* of 300 or more.
3. The *fire area* is located on a floor other than a level of *exit discharge* serving such occupancies.
4. Any Group A-3 occupancy that serves alcohol shall comply with the fire sprinkler requirements for Group A-2 Occupancies in section 903.2.1.2.

*Section 903.2.6 Group I is hereby amended by amending exception 2 as follows:*

**903.2.6 Group I.** An Automatic sprinkler system shall be provided throughout buildings with a Group I fire area.

**Exceptions:**

1. An automatic sprinkler system installed in accordance with Section 903.3.1.2 shall be permitted in Group I-1 Condition 1 facilities.
2. An Automatic sprinkler system is not required where Group I-4 child day care facilities are at the level of exit discharge and where every room where care is provided has not fewer than one exterior exit door.
3. In buildings where Group 1-4 day care is provided on levels other than the level of exit discharge, an automatic sprinkler system in accordance with Section 903.3.1.1 shall be installed on the entire floor where care is provided, all floors between the level of care and the level of exit discharge and all floors below the level of exit discharge other than areas classified as an open parking garage.

*Section 903.2.8 Group R is hereby amended by adding the following exception:*

**903.2.8 Group R.** An *automatic sprinkler system* installed in accordance with Section 903.3 shall be provided throughout all buildings with a Group R *fire area*.



**Exception: FOSTER CARE FAMILY HOME as defined in Section 202 General Definitions.**

*Section 903.2.11.1.1 Opening dimensions and access is amended as follows:*

**903.2.11.1.1 Opening dimensions and access.** Openings shall have a minimum dimension of not less than 30 inches (762 mm). Such openings shall be accessible to the fire department from the exterior and shall not be obstructed in a manner that fire fighting or rescue cannot be accomplished from the exterior. Openings shall have a finished sill height of no more than 44 inches above the finished floor level of the story which the opening is serving.

*Section 903.2 Where required is amended by adding Section 903.2.13 Porte-cocheres as follows:*

**903.2.13 Porte-cocheres.** Porte-cocheres greater than 1000 square feet shall be sprinklered.

*Section 903.3.1.1.1 Exempt locations is amended by adding item 7 to read as follows:*

**903.3.1.1.1 Exempt locations.** Automatic sprinklers shall not be required in the following rooms or areas where such rooms or area are protected with an approved automatic fire detection system in accordance with Section 907.2 that will respond to visible or invisible particles of combustion. Sprinklers shall not be omitted from any room merely because it is damp; of fire resistance rated construction or contains electrical equipment.

1. Any room where the application of water, or flame and water, constitutes a serious life or fire hazard.
2. Any room or space where sprinklers are considered undesirable because of the nature of the contents, when *approved* by the *fire code official*.
3. Generator and transformer rooms separated from the remainder of the building by walls and floor/ceiling or roof/ceiling assemblies having a *fire resistance rating* of not less than 2 hours.
4. Rooms or areas that are of noncombustible construction with wholly noncombustible contents.
5. Fire service access elevator machine rooms and machinery spaces.
6. Machine rooms and machinery spaces associated with occupant evacuation elevators designed in accordance with Section 3008 of the *International Building Code*.
7. Equipment storage areas of fire stations where sprinklers are considered undesirable because of the nature of the contents, including firefighting apparatus and specialized equipment, when *approved* by the *fire code official*.

*Section 903.3.1.2 NFPA 13R sprinkler systems is amended by adding Section 903.3.1.2.3 Elevator Machine Room as follows:*

**903.3.1.2.3 Elevator Machine Room.** In all R occupancies or occupancies using a 13R system with elevator systems, the elevator machine room shall be sprinklered as per NFPA 13 standards.

*SECTION 903 AUTOMATIC SPRINKLER SYSTEMS is amended by adding an exception to Section to 903.4 and by adding a new Section 903.7 Separation from Non-Sprinklered Areas as follows:*

**903.4 Sprinkler system supervision and alarms.** Valves controlling the water supply for automatic sprinkler systems, pumps, tanks, water levels and temperatures, critical air pressures and water flow switches on all sprinkler systems shall be electrically supervised by a listed fire alarm control unit.

**Exceptions:**

1. Automatic sprinkler systems protecting one-and two-family dwellings.
2. Limited area sprinkle systems in accordance with Section 903.3.8.
3. Automatic sprinkler systems installed in accordance with NFPA 13R where a common supply main is used to supply both domestic water and the automatic sprinkler system, and a separate shutoff valve for the automatic sprinkler system is not provided.
4. Jockey pump control valves that are sealed or locked in the open position.
5. Control valves to commercial kitchen hoods, paint spray booths or dip tanks that are sealed or locked in the open position.
6. Valves controlling the fuel supply to fire pump engines that are sealed or locked in the open position.
7. Trim valves to pressure switches in dry, precaution and deluge sprinkler systems that are sealed or locked in the open position
8. Valves located outside buildings or in a vault that are sealed or locked in the open position.

**903.7 Separation from Non-Sprinklered Areas.** Unless otherwise exempted by the 2015 International Building Code (IBC) or 2015 International Fire Code (IFC) or required to be of a higher fire resistive construction by the IBC or IFC, a minimum of one hour fire barrier constructed in accordance with the 2015 International Building Code shall be between sprinklered and non-sprinklered areas within a building.

*Section 904.2.2 Commercial hood and duct systems is amended by adding Section 904.2.2.1 Permit required as follows:*

**904.2.2.1 Permit required.** Prior to installation, a licensed contractor shall obtain a permit for automatic fixed pipe extinguishing system from the Fire Marshal's office. At the time a permit request is made, a diagram detailing exactly what will be installed at the "permit site" shall be submitted for Fire Department review and files. The diagram shall include:

1. Approximate length of pipe and elbows
2. Distance of nozzles from grill area
3. Exact size, type and number of nozzles
4. Number and location of fusible links
5. Size of cooking surface area, hood, and vent area
6. Location of manual pull
7. Location of automatic gas or electric shut-off, electric shut-off is to be a total shut-off
8. The location of the automatic extinguishing system in the room and distance of exits must be shown

The installation is not complete until all automatic electric or gas shut-offs are installed. Permittee is responsible for the total installation. Permittee shall call Fire Prevention for a final inspection after the system is completed. The fire inspector shall require an operations test of the system be performed on the final inspection. Agent discharge shall not be required if: (a) Installer certifies in writing that system has been designed and installed in accordance with manufacturers specifications, and (b) an air discharge test is performed.

*Section 905.1 General is amended by adding Section 905.1.1 Safety factor as follows:*

**905.1.1 Safety factor.** Standpipe systems shall be designed with a minimum 10 psi safety factor taken at the Fire Department Connection for Manual Standpipes, and taken at the base of the standpipe riser for automatic standpipes, for the hydraulically most demanding system and/or outlet.

*Section 905.2 Installation Standard is amended by adding Section 905.2.1 Class-I reducer as follows:*

**905.2.1 Class-I reducer.** A 2.5 inch by 1.5 inch reducer shall be provided on Class-I standpipe connections with caps and chains.

*Section 906.2 General requirements is amended by adding Section 906.2.2 Travel distance as follows:*

**906.2.2 Travel distance.** Travel distance is calculated from a point in the occupancy to the location of fire extinguisher located on the same floor level in accordance with the maximum distances listed in **Table 906.3(1)** or **Table 906.3(2).**

Travel distance is calculated per floor when determining travel distance to a fire extinguisher in multi-story buildings.

*SECTION 906 PORTABLE FIRE EXTINGUISHERS is amended by adding Section 906.5.1 Conspicuous Locations in Group R occupancies as follows:*

**906.5.1 Conspicuous Locations in Group R occupancies.** In addition to other areas listed herein or in NFPA10, fire extinguishers in R occupancies may also be placed in any of the following location to satisfy the requirements:

1. On a wall in the unit;
2. Inside a closet, cabinet or pantry as long as the door has a label indicating that there is a fire extinguisher inside;
3. Inside a mechanical closet as long as the door has a label indicating that there is a fire extinguisher insider; or
4. Inside storage closets as long as the door has a label indicating that there is a fire extinguisher insider and there is no locking device on the door that requires a key or combination to open it.

*SECTION 906 PORTABLE FIRE EXTINGUISHERS is amended by adding Section 906.11 Inspections of Non-Rechargeable Fire Extinguishers in R Occupancies as follows:*

**906.11 Inspections of Non-Rechargeable Fire Extinguishers in R Occupancies.** As an alternative to required fire extinguisher annual inspections conducted by licensed and certified personnel, the owner or management company, their employees or agents are authorized to inspect non-rechargeable fire extinguishers located in R occupancies on an annual basis to ensure that:

1. The extinguisher's service life is not beyond the manufacturer's recommended warranty date;
2. Pin has not been removed;
3. The indicator gauge is in the green or good position;
4. Installed in the proper location per section 906.5;

5. No obvious physical damage, corrosion, or nozzle blockage is present; and
6. The operating instructions are present, legible and facing forward.

The owner or owner's agent shall repair or replace a fire extinguisher if any of the deficiencies noted in items 1-6 above are discovered on inspection.

While inspecting the non-rechargeable fire extinguishers, the inspection personnel shall cause the contents of the non-rechargeable fire extinguishers to be stirred by turning the fire extinguishers upside down at least two times.

In lieu of placing tags or labels on non-rechargeable fire extinguishers to verify inspection, a log or inspection sheet may be maintained indicating compliance with all the requirements above.

*Section 907.1.2 Fire alarm shop drawings is hereby amended as follows:*

**907.1.2 Fire alarm shop drawings.** Shop drawings for fire alarm systems shall be submitted for review and approval prior to system installation, and shall include, but not be limited to, all of the following where applicable to the system being installed:

1. A floor plan that indicates the use of all rooms.
2. Locations of alarm-initiating devices.
3. Locations of alarm notification appliances, including candela ratings for visible alarm notification appliances and tap values for speakers when installed.
4. Design minimum audibility level for occupant notification
5. Location of fire alarm control unit, transponders and notification power supplies.
6. Annunciators.
7. Power connections.
8. Battery calculations. Calculations shall be completed in accordance with NFPA 72, Section 10.5.6.3.1 and 10.5.6.3.2.
9. Conductor type and sizes.
10. Voltage drop calculations. Calculations shall be completed using a maximum starting voltage of 20.4 volts for 24-volt systems and 10.2 volts for 12-volt systems.
11. Manufacturers' data sheets indicating model numbers and listing information for equipment, devices and materials.
12. Details of ceiling height and construction.
13. The interface of fire safety control functions.
14. Classification of the supervising station.
15. For in-building emergency voice alarm communication systems and mass notification systems, speaker circuit load calculations providing a total dB loss at the end of each speaker circuit.
16. Acoustically distinguishable space classifications and designations in accordance with NFPA 72, 2013 Edition, Chapter 18 indicated on the

floor plans in each applicable area with a designation and classification legend provided in tabular form.

17. When utilizing acoustic modeling software to determine acoustically distinguishable spaces, include reports from the modeling software with the submittal package.
18. For aspirating smoke detection systems, full transport time calculations shall be provided with the submittal package.

*Section 907.1 General is amended by adding Section 907.1.4 Testing of Fire Alarm Systems as follows:*

**907.1.4 Testing of Fire Alarm Systems.** The following are required at the time of fire alarm acceptance testing unless approved by the Fire Marshal or his/her designee:

1. The written statement required by NFPA 72, section 4.5.1.2
2. A copy of the Record of Completion as required by NFPA 72, section 4.5.2.1
3. A copy of the Texas Department of Insurance Fire Alarm Installation Certificate
4. Approved plans bearing the original stamp and signature of the fire alarm plan reviewer
5. Original permit is on site.
6. Fire Review Activity form (plan review comments) if provided.
7. Proof of current licensing of the technician performing the tests.
8. Written approvals from the AHJ if partial installation inspections are requested by the contractor or technician.
9. Site specific software for software based systems.
10. Written sequence of operation.
11. All testing equipment necessary to conduct the test (i.e. decibel meter, flashlight, intelligibility meter, etc)

*Section 907.2.1.2 Emergency voice/alarm communication system captions is hereby deleted.*

~~[907.2.1.2 Emergency voice/alarm communication system captions. Stadiums, arenas and grandstands required to caption audible public announcements shall be in accordance with Section 907.5.2.2.4.]~~

*Section 907.2.3 Group E is repealed and replaced with Section 907.2.3 Group E as follows:*

**907.2.3 Group E.** A manual fire alarm system that activates the occupant notification system in accordance with Section 907.5 shall be installed in Group E occupancies. When automatic sprinkler systems or smoke detectors are installed, such systems or detectors shall be connected to the building fire alarm system.

**Exceptions:**

1. A manual fire alarm system is not required in Group E occupancies with an occupant load of less than 50.
2. Manual fire alarm boxes are not required in Group E occupancies where all of the following apply:
  - 2.1. Interior corridors are protected by smoke detectors.
  - 2.2. Auditoriums, cafeterias, gymnasiums and similar areas are protected by heat detectors or other approved devices.
  - 2.3. Shops and laboratories involving dusts or vapors are protected by heat detectors or other approved devices.
  - 2.4. The capability to activate the evacuation signal from a central point is provided.
  - 2.5. In buildings where normally occupied spaces are provided with a two-way communication system between such spaces and a constantly attended receiving station from where a general evacuation alarm can be sounded, except in location specifically designated by the fire code official.
3. Manual fire alarm boxes shall not be required in Group E occupancies where the building is equipped throughout with an approved automatic sprinkler system in accordance with 903.3.1.1, the notification appliances will activate on sprinkler water flow and manual activation is provided from a normally occupied location.

*Section 907.2.7.1 Occupant notification is hereby deleted in its entirety.*

~~[907.2.7.1 Occupant notification. During times that the building is occupied, the initiation of a signal from a manual fire alarm box or from a waterflow switch shall not be required to activate the alarm notification appliances when an alarm signal is activated at a constantly attended location from which evacuation instructions shall be initiated over an emergency voice/alarm communication system installed in accordance with Section 907.5.2.2.]~~

*Section 907.2.8.2 Automatic smoke detection system is hereby amended to read as follows:*

**907.2.8.2 Automatic smoke detection system.** An automatic smoke detection system that activates the occupant notification system in accordance with Section 907.5 shall be installed throughout all interior corridors serving sleeping units. The automatic smoke detection system requirement is met only by the installation of smoke or beam detectors whenever possible. If environmental conditions do not allow the installation of smoke detectors, fire alarm heat detectors may be used on a limited basis when approved by the fire code official.

**Exception:** An automatic smoke detection system is not required in buildings that do not have interior *corridors* serving *sleeping units* and where each *sleeping unit* has a *means of egress* door opening directly to an *exit* or to an exterior *exit access* that leads directly to an *exit*.

**Section [M] 907.2.13.1.2 Duct smoke detection** is amended as follows:

**907.2.13.1.2 Duct smoke detection.** Duct smoke detectors complying with Section 907.3.1 shall be located in accordance with the National Fire Protection Association standard *NFPA 90A: Standard for the Installation of Air-Conditioning and Ventilating Systems* or as follows:

1. In the main return air and exhaust air plenum of each air-conditioning system having a capacity greater than 2,000 cubic feet per minute (cfm) (0.94 m<sup>3</sup>/s). Such detectors shall be located in a serviceable area downstream of the last duct inlet.
2. At each connection to a vertical duct or riser serving two or more stories from a return air duct or plenum of an air-conditioning system. In Group R-1 and R-2 occupancies, a smoke detector is allowed to be used in each return air riser carrying not more than 5,000 cubic feet per minute (cfm) ~~[cfm]~~ (2.4 m<sup>3</sup>/s) and serving not more than 10 air-inlet openings.
- ~~[3. In systems with open air returns, the duct smoke detector shall be placed on the supply side.]~~

*Section 907.2 Where required – new buildings and structures is amended by adding Section 907.2.24 High Occupant Load as follows:*

**907.2.24 High Occupant Load.** In addition to the requirements listed in other sections of this Code, any occupancy having an occupant load of 1000 or more shall be provided with a manual fire alarm system.

**Exception: Open Parking Garages**

*Sections 907.3 Fire safety functions and 907.3.1 Duct smoke detectors are hereby amended to read as follows:*

**907.3 Fire safety functions.** Automatic fire detectors utilized for the purpose of performing fire safety functions shall be connected to the building's fire alarm control unit where a fire alarm system is required by Section 907.2. Detectors shall, upon actuation, perform the intended function and activate the alarm notification appliances or activate a visible and audible supervisory signal at a constantly attended location. In buildings not equipped with a fire alarm system, the automatic fire detector shall be powered by normal electrical service and, upon actuation, perform the intended function. The detectors shall be located in accordance with NFPA 72.

**907.3.1 Duct smoke detectors.** Smoke detectors installed in ducts shall be *listed* for the air velocity, temperature and humidity present in the duct. Duct smoke detectors shall be connected to the building's fire alarm control unit when a fire



alarm system is required by Section 907.2. Activation of a duct smoke detector shall initiate a visible and audible supervisory signal at a constantly attended location and shall perform the intended fire safety function in accordance with this code, *NFPA 90A: Standard for the Installation of Air-Conditioning and Ventilating Systems* and the *International Mechanical Code*. In facilities that are required to be monitored by a supervising station, duct smoke detectors shall report only a supervisory signal and not as a fire alarm. They shall not be used as a substitute for required open area detection.

**Exceptions:**

~~{1. The supervisory signal at a constantly attended location is not required where duct smoke detectors activate the building's alarm notification system.}~~

1. ~~{2.}~~ In occupancies not required to be equipped with a fire alarm system, actuation of a smoke detector shall activate a visible and an audible signal in an approved location. Smoke detector trouble conditions shall activate a visible or audible signal in an approved location and shall be identified as air duct detector trouble.

2. For fire alarm systems which cannot be programmed for supervisory signals, duct detectors shall be allowed to activate the alarm signal.

*Section 907.3.5 Fire Alarm Systems - Emergency Control is hereby added to read as follows:*

**907.3.5 Fire Alarm Systems - Emergency Control.** At a minimum, the following functions, where provided, shall be activated by the fire alarm system:

1. Elevator capture and control in accordance with ASME/ANSI A17.1b, Safety Code for Elevators and Escalators.
2. Release of automatic door closures and hold open devices.
3. Stairwell and/or elevator shaft pressurization.
4. Smoke management and/or smoke control systems.
5. Initiation of automatic fire extinguishing equipment.
6. Emergency lighting control.
7. Unlocking of doors.
8. Emergency shutoff of gas and fuel supplies that may be hazardous provided the continuation of service is not essential to the preservation of life.
9. Emergency shutoff of audio systems for sound reinforcement or entertainment (i.e. music systems, systems for announcement and broadcast which are separate from public address systems) provided that such systems are not used to issue emergency instructions.

10. Emergency shutoff of systems used for the creation of displays or special effects (i.e. lighting effects, laser light shows, projection equipment)

*Section 907.4.2.1 Location is amended to add an exception:*

**907.4.2.1 Location.** Manual fire alarm boxes shall be located not more than 5 feet (1524 mm) from the entrance to each *exit*. In buildings not protected by an *automatic sprinkler system* in accordance with Section 903.3.1.1 or 903.3.1.2, additional manual fire alarm boxes shall be located so that *exit access* travel distance to the nearest box does not exceed 200 feet (60 960 mm).

**Exception:** Where construction of the building prohibits the proper installation of a manual fire alarm box (e.g. glass walls, interior brick or rock walls), a manual fire alarm box shall be allowed to be located in the normal path of egress, where approved by the Fire Marshal or his/her designee.

*Section 907.5.1, Presignal feature, is amended to read as follows:*

**907.5.1 Presignal features and positive alarm sequences.** A Presignal feature or Positive Alarm Sequence as defined in NFPA 72 shall not be installed unless approved by the fire code official and the fire department. Request to use a Presignal feature or a Positive Alarm Sequence must be submitted in writing to the Fire Marshal and approval granted before installation. Where a Presignal feature or Positive Alarm Sequence is provided, a signal shall be annunciated at a constantly attended location *approved* by the fire department, so that occupant notification can be activated in the event of fire or other emergency. When approved by the fire code official, the Presignal feature or Positive Alarm Sequence shall be implemented in accordance with the requirements of NFPA 72.

*Section 907.5.2.1 Audible alarms is amended by adding Sections 907.5.2.1.4 Testing of Audible Alarms in occupancies other than group R and 907.5.2.1.5 Testing of Audible Alarms in Group R occupancies as follows:*

**907.5.2.1.4 Testing of Audible Alarms in occupancies other than group R.** Audibility levels for all occupancies other than Group R shall be in accordance with the public mode requirements of NFPA 72, and shall be tested utilizing the following criteria:

1. A sound pressure level meter, which has been calibrated within the last calendar year, and supplied by the fire alarm system installing contractor, shall be utilized to obtain readings. The audiometer will be held five feet above floor, pointed in the direction of the audible device.
2. All doors within the occupancy, including bathroom doors and balconies, shall be in the closed position.

3. Levels shall be taken in the most remote areas of the occupancy first, including bathrooms and balconies.
4. Initial readings to confirm the average ambient sound level in each area shall be taken.
5. The fire alarm system shall be activated and readings in the tested areas shall be retaken and compared with the requirements.

**907.5.2.1.5 Testing of Audible Alarms in Group R occupancies.** Audibility levels for all Group R occupancies shall be in accordance with the requirements of Section 907.5.2.1.1, and shall be tested utilizing the following criteria:

1. A sound pressure level meter, which has been calibrated within the last calendar year, and supplied by the fire alarm system installing contractor, shall be utilized to obtain readings. The audiometer will be held five feet above floor, pointed in the direction of the audible device.
2. All doors within the occupancy, including the bathroom and balcony doors shall be in the closed position.
3. Ambient sound level shall be established with the television set at 50 percent of maximum volume, showers running, bathroom exhaust systems running, and air conditioning units running.
4. Levels shall be taken in the most remote area of the dwelling or sleeping unit first, including bathrooms and balconies.
5. Initial readings to confirm the ambient sound level in each area shall be taken.
6. The fire alarm system shall be activated and readings in the tested areas shall be retaken and compared with the requirements.

*Section 907.5.2.2, Emergency voice/alarm communication systems, is amended as follows:*

**907.5.2.2 Emergency voice/alarm communication systems.** Emergency voice/alarm communication systems required by this code shall be designed and installed in accordance with NFPA 72. The operation of any automatic fire detector, sprinkler waterflow device or manual fire alarm box shall automatically sound an alert tone followed by voice instructions giving *approved* information and directions for a general or staged evacuation in accordance with the building's fire safety and evacuation plans required by section 404 of the *International Fire Code*. In high-rise buildings, the system shall operate on a minimum of the alarming floor, the floor above and the floor below. If the system is not reset after five minutes, the building shall sound the general evacuation signal and message in all zones unless an alternative Positive Alarm Sequence has been approved by the Fire Marshal. Speakers shall be provided throughout the building by paging zones. At a minimum, paging zones shall be provided as follows:

1. Elevator groups

2. *Interior exit stairways*
3. Each floor
4. *Areas of refuge* as defined in Chapter 2.

**Exception:** In Group I-1 and I-2 occupancies, the alarm shall sound in a constantly attended area and a general occupant notification shall be broadcast over the overhead page.

*Section 907.5.2.2.4 Emergency voice/alarm communication captions is hereby deleted.*

~~[907.5.2.2.4 Emergency voice/alarm communication captions. Where stadiums, arenas and grandstands are required to caption audible public announcements in accordance with Section 1108.2.7.3 of the International Building Code, the emergency/voice alarm communication system shall be captioned. Prerecorded or live emergency captions shall be from an approved location constantly attended by personnel trained to respond to an emergency.]~~

*Section 907.5.2.3.3 Group R-2 is amended to read as follows:*

**907.5.2.3.3 Group R-2.** In Group R-2 occupancies required by Section 907 to have a fire alarm system, all *dwelling units* and *sleeping units* shall be provided with the capability to support visible alarm notification appliances in accordance with ICC A117.1 [Chapter 10 of ICC A117.1]. This requirement is met by extending the fire alarm wiring to all living areas, restrooms and sleeping areas of all units. The wiring must terminate in an electrical box suitable for securely mounting an audio/visual device. Circuits shall be calculated with a minimum 20 percent safety factor available at the end of the circuit. ~~[Such capability shall be permitted to include the potential for future interconnection of the building fire alarm system with the unit smoke alarms, replacement of audible appliances with combination audible/visible appliances, or future extension of the existing wiring from the unit smoke alarm locations to require locations for visible appliances.]~~

**Exception:** Group R-2 complexes that install a minimum of 200% of the visible and audible alarms required in table 907.5.2.3.3 for Group I-1 and R-1 occupancies will be exempt from pre-wiring every individual unit under this section. For this exception to be used, the owner of the complex must sign and return the Letter of Understanding Form 6007, which can be obtained from SAFD Fire Prevention. The designer shall calculate the notification appliances circuits for units so equipped with a minimum twenty (20) percent safety factor available at the end of the circuit.

*Section 907.5.2.3.4 Group R-2 Sleeping Areas is added to read as follows:*

**907.5.2.3.4 Group R-2 Sleeping Areas.** Living rooms in Group R-2 Occupancies shall have visible notification devices that meet the effective intensity requirements of NFPA 72, Table 18.5.4.6.2 and meet the minimum audibility requirements of section 907.5.2.1.1.

*Section 907.5.2.3.5 Combination Devices is added to read as follows:*

**907.5.2.3.5 Combination Devices.** Combination 120 VAC single or multiple-station smoke detectors with an onboard visible notification appliance if utilized to meet the requirements of Section 907.2.11, will not be given credit for meeting the visible alarm notification requirements of Section 907.5.2.3.3 if these devices do not have the capability of supplying backup power for the visible notification appliance portion of the device. Should such devices be utilized to comply with Section 907.2.11, the visible appliance side of the device shall flash in synchronization with the notification appliances required in the unit.

*SECTION 907 FIRE ALARM AND DETECTION SYSTEMS is amended by adding Section 907.10 Alarm Signal Silencing Switch as follows:*

**907.10 Alarm Signal Silencing Switch.** A switch for silencing the alarm signal sounding appliances shall be permitted only if it is key operated, located within a locked cabinet, or requires special knowledge. Such a switch shall be permitted only if visible zone alarm indication or equivalent has been provided by approved annunciation, printout, or other approved means, and subsequent alarms on other initiating devices circuits will cause the audible alarm signaling appliances to resound. A switch that is left in the "silence" position when there is no alarm shall operate trouble signals until the switch is restored to normal.

*Section 912.4.1 Locking Fire Department Connection Caps is amended to read as follows:*

**912.4.1 Locking Fire Department Connection Caps.** FDC shall have locking caps in the following areas/occupancies: The area described in section 11-37 of these amendments, Group A, E, I occupancies, High-Rise buildings, and any other location a fire code official determines that a locking cap would be necessary and/or beneficial for firefighting needs. [~~The fire code official is authorized to require locking caps on fire department connections for water-based fire protection systems where the responding fire department carries appropriate key wrenches for removal.~~]

*SECTION 912 FIRE DEPARTMENT CONNECTIONS is amended by adding Section 912.8 Fire Department Connections and Table 912.8 as follows:*

**912.8 Fire Department Connections.** Sprinkler system and standpipe fire department hose connections shall be as follows:

1. Within forty (40) feet of a public street, approved fire lane, or access roadway;

2. Within 250 feet of an approved fire hydrant measured per hose lay criteria in Section 507.5.1.2, except for R-2 Apartments in which the fire department connection shall be within 500 feet of an approved fire hydrant measured per hose lay criteria in Section 507.5.1.2;
3. Minimum of two feet above finished grade and a maximum of four feet above finished grade for standard inlets and minimum of 30 inches at lowest point above finished grade, and maximum of four feet above finished grade for the five inch “Storz” inlet;
4. The Fire Code Official shall approve the location of freestanding fire department connections. Freestanding FDCs must be physically protected against impact per the requirements of Section 312 or other *approved* means.
5. Where provided, the five inch “Storz” inlet shall be installed at a 30 degree angle pointing down;
6. Fire department connections for H occupancies will be freestanding remote and located as determined by the Fire Code Official; and
7. See table 912.8

**Table 912.8**  
**FDC Connections required by System Type**

<u>Sprinkler Systems:</u> <u>Wet</u> <u>Dry</u>	<u>Either a 5 Inch Storz inlet or (2)2 ½ Inch inlets</u>		
<u>Standpipes:</u> <u>Automatic Wet</u> <u>Automatic Dry</u> <u>Semiautomatic</u> <u>Dry</u>		<u>Either a 5 Inch Storz inlet or (2)2 ½ Inch inlets</u>	
<u>Standpipes:</u> <u>Manual Wet</u> <u>Manual Dry</u>			<u>A 5 Inch Storz inlet for the first 1000 gallons system demand and an additional 2 ½ inlet for every 250 gallon demand or portion thereof</u>

There shall be no more than one Storz connection in any configuration \*One (1) 2.5 inch inlet is required for all systems designed per NFPA 13R. If the system demand is greater than 250 GPM, two (2) 2.5 inch inlets are required to be installed. No FDC is required for projects designed per NFPA 13D.

*SECTION 1003 GENERAL MEANS OF EGRESS is amended by adding Section [BE]1003.8 Special Provisions as follows:*

**[BE]1003.8 Special Provisions.** Rooms in E occupancies used for kindergarten or daycare, children five or under, classified as an E occupancy shall not be located above or below the first story.

**Exceptions:**

1. Basements or stories having floor levels located within four feet, measured vertically, from adjacent ground level at the level of exit discharge, provided the basement or story has exterior exit doors at that level.
2. In buildings equipped with an automatic sprinkler system throughout, rooms used for kindergarten or for daycare purposes may be located on the second story, provided there are at least two exterior exit doors for the exclusive use of such occupancies.

*Section [B]1004.1.2 Areas without fixed seating, is amended to read as follows:*

**[B]1004.1.2 Areas without fixed seating.** The number of occupants shall be computed at the rate of one occupant per unit of area as prescribed in Table 1004.1.2. For areas without *fixed seating*, the occupant load shall not be less than that number determined by dividing the floor area under consideration by the occupant load factor assigned to the function of the space as set forth in Table 1004.1.2. Where an intended function is not listed in Table 1004.1.2, the Building Official [~~fire code official~~] shall establish a function based on a listed use that most nearly resembles the intended function. When the calculated number is not a whole number, it is required to round up to the next whole number for determination of the *occupant load* of a space.

**Exception:** Where *approved* by the Building Official [~~fire code official~~], the actual number of occupants for whom each occupied space, floor or building is designed, although less than those determined by calculation, shall be permitted to be used in the determination of the design *occupant load*.

*Section [B]1008.3 Emergency power for illumination is amended by adding Section 1008.3.2.2 Illumination in Group E as follows:*

**1008.3.2.2 Illumination in Group E.** Group E occupancies shall have emergency lighting in interior stairs, corridors, windowless areas with student occupancy, shops, and laboratories.

*SECTION 1009, ACCESSIBLE MEANS OF EGRESS, is repealed and replaced with a new SECTION 1009 to read as follows:*

**SECTION 1009 ACCESSIBLE MEANS OF EGRESS**

All buildings or portions of buildings must comply with the accessibility standards adopted by the State. Projects shall be submitted to the Texas Department of Licensing and Regulation for review, inspection and approval in accordance with state law.

*Section 1103.2 Emergency responder radio coverage in existing buildings is amended to read as follows:*

**1103.2 Emergency responder radio coverage in existing buildings.** Existing buildings that do not have approved radio coverage for emergency responders within the building based upon the existing coverage levels of the public safety communication systems of the jurisdiction at the exterior of the building, shall be equipped with such coverage according to one of the following:

1. Emergency responder radio coverage as required in section 510 of this code is installed within a time frame established by the adopting authority. [~~Whenever an existing wired communication system cannot be repaired or is being replaced, or where not approved in accordance with section 510.1, Exception 1.~~]
2. An approved alternative method of emergency responder communication within the building is provided within a time frame established by the adopting authority. [~~Within a time frame established by the adopting authority.~~]

**Exception:** Where it is determined by the *fire code official* that the radio coverage system is not needed.

*Sections 1103.4.2 Three to five stories, 1103.4.4 Atriums and covered malls, 1103.4.5 Escalators in Group B and M occupancies, 1103.4.6 Escalators connecting four or fewer stories, 1103.6 Standpipes and 1103.7.6 Group R-2* are all hereby repealed.

*Section 1103.8 Single and multiple-station smoke alarms* is amended to add an exception as follows:

**1103.8 Single- and multiple-station smoke alarms.** Single- and multiple-station smoke alarms shall be installed in existing Group I-1 and R occupancies in accordance with Sections 1103.8.1 through 1103.8.3.

**Exception:** All R3 occupancies not used for commercial purposes, including duplexes and houses for rent.

*Section 1103.8.1 Where required* is amended by deleting the first two exceptions as follows:

**1103.8.1 Where required.** Existing Group I-1 and R occupancies shall be provided with single-station smoke alarms in accordance with Section 907.2.11, except as provided in Section 1103.8.2 and 1103.8.3.

**Exception[s]:**

- [~~1. Where the code that was in effect at the time of construction required smoke alarms and smoke alarms complying with those requirements are already provided.~~]



~~[2. Where smoke alarms have been installed in occupancies and dwellings that were not required to have them at the time of construction, additional smoke alarms shall not be required provided that the existing smoke alarms comply with requirements that were in effect at the time of installation.~~

~~[3].~~1. Where smoke detectors connected to a fire alarm system have been installed as a substitute for smoke alarms if installed in all sleeping areas as prescribed in 907.2.11.

*Section 1103.8.2 Interconnection is amended by altering the two exceptions as follows:*

**1103.8.2 Interconnection.** Where more than one smoke alarm is required to be installed within an individual dwelling or sleeping unit, the smoke alarms shall be interconnected in such a manner that the activation of one alarm will activate all of the alarms in the individual unit. The alarm shall be clearly audible in all bedrooms over background noise levels with all intervening doors closed.

**Exceptions:**

1. Interconnection is not required in buildings that are not undergoing *alterations* [~~repairs or construction of any kind~~].
2. Smoke alarms in existing areas are not required to be interconnected where *alterations* do not result in the removal of interior wall or ceiling finishes exposes the structure [~~unless there is an attic, crawl space or basement available which could provide access for interconnection without the removal of interior finishes~~].

*Section 1103.8.3 Power source is amended by adding two new exceptions as follows:*

**1103.8.3 Power source.** Single-station smoke alarms shall received their primary power from the building wiring provided that such wiring is served from a commercial source and shall be equipped with a battery backup. Smoke alarms with integral strobes that are not equipped with battery backup shall be connected to an emergency electrical system. Smoke alarms shall emit a signal when the batteries are low. Wiring shall be permanent and without a disconnecting switch other than as required for overcurrent protection.

**Exceptions:**

1. Smoke alarms are permitted to be solely battery operated in existing buildings where no construction is taking place.
2. Smoke alarms are permitted to be solely battery operated in buildings that are not served from a commercial power source.
3. Smoke alarms are permitted to be solely battery operated in existing areas of buildings undergoing alterations or repairs that do not result in the removal of interior walls or ceiling finishes exposing the structure,

unless there is an attic, crawl space or basement available which could provide access for building wiring without the removal of interior finishes.

4. In all R-2 occupancies, smoke alarms are permitted to be solely battery operated if added to comply with 1103.8.
5. In all R-2 occupancies, smoke alarms are permitted to be operated solely from the building wiring if installed prior to the adoption date of this code.

*Section 1103.9 Carbon monoxide alarms is amended to read as follows:*

**1103.9 Carbon monoxide alarms.** Existing Group I-1, I-2[;] and I-4 [~~and R~~] occupancies shall be equipped with carbon monoxide alarms in accordance with Section 915, except that the carbon monoxide alarms shall be allowed to be solely battery operated.

*Section 1104.1 General is amended to read as follows:*

**1104.1 General.** *Means of egress* in existing buildings shall comply with the minimum egress requirements when specified in Table 1103.1 as further enumerated in Sections 1104.2 through 1104.25, or [and] the building code that applied at the time of construction, if in the opinion of the fire code official, they do not constitute a distinct hazard to life. [~~Where the provisions of this chapter conflict with the building code that applied at the time of construction, the most restrictive provision shall apply.~~] Existing buildings that were not required to comply with a building code at the time of construction shall comply with the minimum egress requirements when [where] specified in Table 1103.1 as further enumerated in Sections 1104.2 through 1104.25 and, in addition, shall have a life safety evaluation prepared, consistent with the requirements of Section 403.2.10 and 403.2.11. The life safety evaluation shall identify any changes to the means of egress that are necessary to provide safe egress to occupants and shall be subject to review and approval by the fire code official. The building shall be modified to comply with the recommendations as set forth in the approved evaluation.

*Section 1104.5 Illumination emergency power for Group R-2 is amended as follows:*

**1104.5 Illumination emergency power.** Where means of egress illumination is provided, the power supply for *means of egress* illumination shall normally be provided by the premises' electrical supply. In the event of power supply failure, illumination shall be automatically provided from an emergency system for the following occupancies where such occupancies require two or more *means of egress*:

8. Group R-2 in interior stairs and corridors only.

**Exception:** Where each dwelling unit or sleeping unit has direct access to the outside of the building at grade.

*Section 1104.16.2 Protection of openings is hereby deleted in its entirety.*  
~~[1104.16.2 Protection of openings. Openings within 10 feet (3048 mm) of fire escape stairways shall be protected by opening protectives having a minimum ¾-hour fire protection rating.]~~

~~[Exception: In buildings equipped throughout with an approved automatic sprinkler system, opening protection is not required.]~~

*Section 1104.16 Fire escape stairs is amended by adding Section 1104.16.8 Exterior Fire Escape as follows:*

**1104.16.8 Exterior Fire Escape.** Any existing exterior fire escape which is deemed to be an adequate fire escape under the laws of the State or under the provisions of the City fire prevention regulations shall be deemed an adequate means of egress for emergency use as required by this chapter and the number of existing exterior fire escapes shall be provided to comply with the fire escape law of the State and the City fire prevention regulations.

*TABLE 1104.18 COMMON PATH, DEAD-END AND TRAVEL DISTANCE LIMITS (by occupancy) is amended by altering the number of "Dead-End Limit" Sprinklered (feet) chart for the following occupancy groups listed.*

**TABLE 1104.18  
 COMMON PATH, DEAD-END AND TRAVEL DISTANCE LIMITS (by  
 occupancy)**

OCCUPANCY	COMMON PATH LIMIT		DEAD-END LIMIT		TRAVEL DISTANCE LIMIT	
	Unsprinklered (feet)	Sprinklered (feet)	Unsprinklered (feet)	Sprinklered (feet)	Unsprinklered (feet)	Sprinklered (feet)
Group A	20/75 <sup>a</sup>	20/75 <sup>a</sup>	20 <sup>b</sup>	20 <sup>b</sup>	200	250
Group B <sup>h</sup>	75	100	50	<u>70</u> [50]	200	300
Group E	75	75	20	<u>70</u> [50]	200	250
Group F-1d, S-1 <sup>d, h</sup>	75	100	50	<u>70</u> [50]	200	250
Group F-2d, S-2 <sup>i, h</sup>	75	100	50	<u>70</u> [50]	300	400
Group H-1	25	25	0	0	75	75
Group H-2	50	100	0	<u>0</u>	75	100
Group H-3	50	100	20	20	100	150
Group H-4	75	75	20	<u>20</u>	150	175
Group H-5	75	75	20	50	150	200
Group I-1	75	75	20	<u>70</u> [50]	200	250
Group I-2	Notes e,g	Notes e, g	Note f	Note f	150	200 <sup>c</sup>

Group I-3	100	100	NR	NR	150	200
Group I-4 (Day care centers)	NR	NR	20	20	200	250
Group M (Covered or Open Mall)	75	100	50	70 [50]	200	400
Group M (Mercantile)	75	100	50	70 [50]	200	250
Group R-1 (Hotels)	75	75	50	70 [50]	200	250
Group R-2 (Apartments)	75	125	50	70 [50]	200	250
Group R-3 (One- and two-family)	NR	NR	NR	NR	NR	NR
Group R-4 (Residential care/assisted living)	NR	NR	NR	NR	NR	NR
Group U <sup>h</sup>	75	100	20	70 [50]	300	400

*Section 1104.22 Exterior stairway protection is hereby repealed in its entirety.*

*Section 1104.25 Egress path markings is hereby deleted.*

~~[1104.25 Egress path markings. Existing high-rise buildings of Group A, B, E, I, M and R-1 occupancies shall be provided with luminous egress path marks in accordance with Section 1025.~~

~~**Exception:** Open, unenclosed stairwells in historic buildings designated as historic under a state or local historic preservation program.]~~

*SECTION 2301 GENERAL is amended by adding Section 2301.7 Portable Service Stations as follows:*

**2301.7 Portable Service Stations.**

1. No person shall own, operate or maintain a tank used for the storage of flammable liquids maintained on skids or a similar type stand which is designed or intended to be used for dispensing flammable liquids into the fuel tanks of motor vehicles owned by the public.
2. The foregoing provisions of this article are intended to prohibit the use of so-called portable service station or similar units constructed to dispense flammable liquids to the motoring public and designed so that the unit can be easily picked up and moved.

*Section 2303.2 Emergency disconnect switches. is hereby amended as follows:*

**2303.2 Emergency disconnect switches.** An *approved*, clearly identified and readily accessible emergency disconnect switch shall be provided at an *approved* location to stop the transfer of fuel to the fuel dispensers in the event of a fuel spill or other emergency. An emergency disconnect switch for exterior fuel dispensers shall be located within 100 feet (30 480 mm) of, but not less than 20 feet (6096 mm) from, the fuel dispensers. For interior fuel-dispensing operations, the emergency disconnect switch shall be installed at an *approved* location. Such devices shall be distinctly *labeled* as: EMERGENCY FUEL SHUTOFF. Signs shall be provided in *approved* locations and be a minimum of 18 inches high and 24 inches wide.

*Section 2303.2.1 Additional Emergency disconnect switches for attended self service is hereby added as follows:*

**2303.2.1 Additional emergency disconnect for attended self service.** Attended facilities shall have an additional emergency disconnect switch located inside the building for attendant use at a location approved by the fire code official.

*Section 2306.2.1.1 Inventory Control for underground tanks is amended to read as follows:*

**2306.2.1.1 Inventory Control for underground tanks.**

Accurate daily (normal working days only) inventory records shall be maintained and reconciled on all Class I, II or III-A liquid [underground] storage tanks for indication of possible leakage from tanks or piping. The records shall be made available for inspection by the Fire Marshal, and shall include, as a minimum, records showing by [for each] product; [showing] daily reconciliation between sales, use, receipts, and inventory on hand. If there is more than one system consisting of a tank(s), serving pump(s), or dispenser(s) for any product, the reconciliation shall be made separately for each tank system. [Where there is more than one system consisting of tanks serving separate pumps or dispensers for a product, the reconciliation shall be ascertained separately for each tank system. A consistent or accidental loss of product shall be immediately reported to the fire code official.]

1. Daily inventory shall be maintained for each tank system at each location by the operator. The inventory records shall be kept for the past 12 months at the premises.
2. Inventory shall be based on the actual daily measurement and recording daily recording of actual sales, or by readout from an automated gauging system. The inventory records shall include a daily compilation of gain or loss. The mere recording of pump meter reading and product delivery receipts shall not constitute adequate inventory records.

3. The operator of the location shall be held responsible for notifying the owner or person(s) in control of the facility to take action to correct any abnormal loss or gain not explainable by spillage, temperature variations or both causes.
4. The Fire Marshal may require the operator of an underground tank storage system to test the system for tightness, at the operator's expense, when accurate daily inventory records have not been maintained as required or when in his judgment conditions indicate possible leakage of product from the location of such tanks.
5. The Fire Marshal may require copies of Class I, II and III-A liquid storage tank inventories, deliveries or receipt of product sales and dip gauge stick readings or other control measures in addition to copies of any tank tightness or line leakage test results from the station operator, agent, or terminal management.
6. When a service station tank is found to be leaking, its contents shall be removed immediately. If any investigations or tests indicate the source of such loss, the owner shall take immediate action to correct the system failure and remove dangerous spillage from the environment.
7. The Fire Marshal may order the closure of a Service Station by barricading if necessary and the emptying of contents from storage tanks should the operator of a service station be unwilling to cooperate with the Fire Department during the search for the source of such leakage or should the Fire Marshal determine that a hazardous condition exists that merits such action.

*Section 2306.2.3 Above-ground tanks located outside, above grade is amended by adding Sections 2306.2.3.1 Inspections, 2306.2.3.2 Required Access, and 2306.2.3.3 Fire Hydrant Access as follows:*

**2306.2.3.1 Inspections.** An inspection of the installation shall be conducted prior to loading the tank with fuel. For those installations approved by the Fire Chief or his designee to dispense class 1 liquids, the initial loading of fuel shall be witnessed by the fire inspector.

**2306.2.3.2 Required Access.** Fire apparatus access roads shall be provided for every aboveground storage tank. The aboveground storage tank shall not be more than 150 feet from fire apparatus access roads as measured by an approved route.

**2306.2.3.3 Fire Hydrant Access.** A minimum of one fire hydrant shall be provided for every aboveground storage tank. The aboveground storage tank shall not be located more than 500 feet from a fire hydrant as measured by an approved route.

*SECTION 2307 LIQUIFIED PETROLEUM GAS MOTOR FUEL-DISPENSING FACILITIES is hereby amended by amending Section 2307.5 Additional requirements for LP-gas dispensers and equipment and Section 2307.6.4 Vehicle Impact Protection as follows:*

**2307.5 Additional requirements for LP-gas dispensers and equipment.** LP-gas dispensers and related equipment shall comply with the following provisions:

1. Pumps shall be fixed in place and shall be designed to allow control of the flow and to prevent leakage and accidental discharge.
2. Dispensing devices installed within 20 feet [~~10 feet (3048 mm)~~] of where vehicle traffic occurs shall be protected against physical damage by mounting on a concrete island 6 inches (152 mm) or more in height, or shall be protected in accordance with section 312.
3. Dispensing devices shall be securely fastened to their mounting surface in accordance with the dispenser manufacturer's instructions.

**2307.6.4 Vehicle impact protection.** Where installed within 20 feet [~~10 feet~~] of vehicle traffic, LP-gas storage containers, pumps and dispensers shall be protected in accordance with Section 2307.5, Item 2.

**SECTION 2809 EXTERIOR STORAGE OF FINISHED LUMBER PRODUCTS** is amended by adding Section 2809.6 Lumber storage other than commercial lumber dealers as follows:

**2809.6 Lumber storage other than commercial lumber dealers.** It shall be unlawful for any person within the City limits to place, pile, or cause to be placed or piled, any lumber or timber to a greater height than six feet at the top most portion from ground level. Storage of lumber in such instances must allow at least an 18 inch space from ground level to bottom of the lumber pile. Such pile must be at least three feet from any adjoining property line and total pile area shall not exceed 100 square feet. Any lumber stored or kept upon, or in, any premises in the City must be piled in a neat and orderly manner free from rubbish or other waste materials. Nothing in this section shall apply to storage of lumber by commercial lumber dealers.

*Section 3103.2 Approval required* is amended to read as follows:

**3103.2 Approval required.** Tents and membrane structures used for assembly purposes having an occupant load over 50, and all other occupancies having an area in excess of 1200 square feet [~~having an area in excess of 400 square feet (37 m<sup>2</sup>)~~] shall not be erected, operated or maintained for any purpose without first obtaining a permit and approval from the *fire code official*.

*Section 3103.4 Permits* is amended to read as follows:

**3103.4 Permits.** Permit to operate a tent or air supported structure shall consist of a Certificate of Occupancy issued by Development Services. [~~Permits shall be required as set forth in Sections 105.6 and 105.7.~~]

*Section 3301.3 Address numbers,* is added to read as follows:

**3301.3 Address numbers.** Buildings under construction shall place address numbers and/or building numbers in a position that is plainly legible and visible from the street or road fronting the property with minimum six inch numbers.

*Section 3314.3 Furniture, Fixtures, and Equipment is hereby added as follows:*

**3314.3 Furniture, Fixtures, and Equipment.** In buildings where and automatic sprinkler system is required, furniture, fixtures, and equipment shall not be stored in the building until the system has been tested and approved by the fire code official and monitoring of system is active.

**Exception:** As approved by the fire code official.

*Chapter 37 COMBUSTIBLE FIBERS is hereby amended by adding section 3706 Construction and Protection Requirements as follows:*

**3706 Construction and Protection Requirements.**

1. Handling and storage of large quantities of waste paper, rags, or other combustible materials shall not be allowed in a building of any type in excess of 1500 square feet area unless the building is protected with an approved automatic sprinkler system.
2. Handling and storage building for waste paper, rags or other combustible materials shall not exceed one story in height unless of Type I construction and fully protected with approved automatic sprinkler system.
3. No loose waste paper, rags, trash or rubbish of any kind, or similar combustible materials shall be allowed on the premises on the outside of any building.
4. Bales, waste paper, rags, and other combustibles in baled lots shall be stored in buildings. Said buildings shall be required to have aisles when 25,000 cubic feet or more of such materials are stored. Baled materials, if stored outside of buildings, shall not be stored within 25 feet of any building. EXCEPTION: Baled materials may be stored within 25 feet of a building's outside wall when a wall sprinkler curtain is provided on the building.

*CHAPTER 38 entitled PROTECTION OF OUTDOOR STORAGE is hereby added to read as follows:*

**CHAPTER 38 PROTECTION OF OUTDOOR STORAGE**

**3801 GENERAL**



**3801.1** The hazards of exposure to outdoor storage from ignition sources and exposing fires and the infinite variety of conditions under which such exposures can occur render impossible the formulation of any single table, formula, or set of rules that can cover all conditions adequately.

**3801.2** In general, the provision of automatic fire protection is impractical for outdoor storage. As a result, the following is required:

1. Control of potential ignition sources such as from exposing buildings, transformers, yard equipment, refuse burners, overhead power lines, and vandals;
2. Elimination of adverse factors such as trash accumulations, weeds, and brush;
3. Provision of favorable physical conditions such as limited pile sizes, low storage heights, wide aisles, and possible use of fire-retardant covers (e.g., tarpaulins);
4. Rapid and effective application of manual fire-fighting efforts by the provision of fire alarms, strategically located hydrants, and adequate hose houses or hose reels.

**3801.3** Outdoor storage is acceptable for materials that are as follows:

1. Of low fire hazard, not requiring protection even if located indoors
2. Of sufficiently low value that a potential loss would not justify the utilization of building space
3. Of such severe fire hazard that indoor protection is impractical when balanced against potential loss of large volume and bulk, making it impractical to construct and protect a building to house the storage.

**3801.4** Where materials that normally would be stored in buildings are stored outdoors in temporary emergencies, special precautions shall be taken for their safeguard and that they be moved to a storage warehouse as soon as possible.

## **3802 Responsibilities of Management**

**3802.1** It is the responsibility of management to properly consider the hazards of the various materials handled. Protection requirements and storage arrangements vary with the combustibility of the materials. The care, cleanliness, and maintenance exercised by management determine to a large extent the relative fire safety in the storage area.

### **3803 Site**

**3803.1** In selecting a site for outdoor storage, the following requirements shall be followed:

1. Adequate public water system with hydrants suitably located for protection of the storage.
2. Adequate all-weather roads for fire department apparatus response.
3. Sufficient clear space from buildings or from other combustible storage that constitutes an exposure hazard.
4. Absence of flood hazards.
5. Adequate clearance space between storage piles and any highways, bridges, railroads, and woodlands.
6. Topography as level as possible to provide storage stability.
7. Adequate clearance between the storage of combustible materials and pipelines, pipe bridges, cable trays and electrical transmission lines.

**3803.2** The entire site shall be surrounded by a fence or other suitable means to prevent unauthorized access. An adequate number of gates shall be provided in the surrounding fence or other barriers to permit ready access of fire apparatus.

### **3804 Material Piling**

**3804.1** Materials shall be stored in unit piles as low in height and small in area as is consistent with good practice for the materials stored. The maximum height shall be determined by the stability of pile, effective reach of hose streams, combustibility of the commodity, and ease of pile breakdown under fire or mop-up conditions. Under no circumstances shall the pile size dimensions exceed 50 feet by 150 feet by 20 feet high unless the specific commodities maximum dimensions are listed elsewhere in the code.

**3804.2** Aisles shall be maintained between individual piles, between piles and buildings, and between piles and the boundary line of the storage site. Sufficient driveways having the width of at least 20 ft shall be provided to allow the travel of fire equipment to all portions of the storage area. Aisles shall be at least twice the pile height to reduce the spread of fire from pile to pile and to allow ready access for fire fighting, emergency removal of material, or salvage purposes.

3804.3 As the commodity class increases in combustibility or where storage could be ignited easily from radiation, wider aisles shall be provided. Smaller unit piles could be an alternative to wider aisles if yard space is limited.

3804.4 Boundary posts with signs designating piling limits shall be provided to indicate yard area, roadway, and aisle limits.

### **3805 Buildings and Other Structures**

3805.1 Yard storage, particularly storage of commodities in the higher heat release category, shall have as much separation as is practical from important buildings and structures, but not less than that offered by NFPA 80A, Recommended Practice for Protection of Buildings from Exterior Fire Exposures.

3805.2 As guidance in using NFPA 80A to establish clear spaces, the following classification of severity with commodity classes of this standard shall be used on the basis of 100 percent openings representing yard storage:

1. Light severity—Commodity Class I
2. Moderate severity—Commodity Class II
3. Interpolate between moderate and severe severity for Commodity Class III
4. Severe severity—Commodity Class IV and Class A plastics

The guidelines of Section 3805.2 apply to the equivalent commodity classes of this standard. The severity of the exposing building or structure also shall be a consideration where establishing a clear space.

### **3806 Yard Maintenance and Operations**

3806.1 The entire storage site shall be kept free from accumulation of unnecessary combustible materials. Vegetation shall be kept to a maximum of four inches high. Procedures shall be provided for weed control and the periodic cleanup of the yard area.

3806.2 No heating equipment shall be located or used within the storage area. Salamanders, braziers, portable heaters, and other open fires shall not be used.

3806.3 Smoking shall be prohibited, except in locations prominently designated as smoking areas. "No Smoking" signs shall be posted in prohibited areas.

3806.4 Welding and cutting operations shall be prohibited in the storage area.

**3806.5** Tarpaulins used for protection of storage against the weather shall be of fire-retardant fabric.

**3806.6** Motorized vehicles using gasoline, diesel fuel, or liquefied petroleum gas as fuel shall be garaged in a separate, detached building.

**3807 Fire Protection**

**3807.1** Fire extinguishers of an appropriate type shall be placed at well-marked strategic points throughout the storage area so that one or more portable fire extinguisher units can quickly be made available for use at any point. Where the climate is such that there is a danger of freezing, suitable extinguishers for freezing temperatures shall be used.

**3808 Storage of Idle Pallets**

**3808.1 General.** Idle pallets shall be stored outside or in a separate building designed for pallet storage, unless permitted in Section 4808.2.

**3808.2 Indoor Storage.** Idle pallets shall be permitted to be stored in a building used for other storage or other purpose, if the building is sprinklered in accordance with NFPA 13, Standard for the Installation of Sprinkler Systems.

**3808.3 Outdoor Storage.** Idle pallets stored outside shall be stored in accordance with **Table 3808.3 (a)** and **Table 3808.3 (b)**.

**Table 3808.3 (a) Required Clearance Between Outside Pallet Storage and Other Yard Storage.**

<u>Pile Size</u>	<u>Minimum Distance</u>	
	<u>m</u>	<u>ft</u>
<u>Under 50 pallets</u>	<u>6.0</u>	<u>20</u>
<u>50—200 pallets</u>	<u>9.1</u>	<u>30</u>
<u>Over 200 pallets</u>	<u>15.2</u>	<u>50</u>

**Table 3808.3 (b) Required Clearance between Outside Pallet Storage and Building**

<u>Wall Construction</u>	<u>Minimum distance of Wall from Storage</u>		
	<u>&lt;50 pallets</u>	<u>50 to 200 pallets</u>	<u>&gt;200 pallets</u>

<u>Wall Type</u>	<u>Openings</u>	<u>m</u>	<u>ft</u>	<u>m</u>	<u>ft</u>	<u>m</u>	<u>ft</u>
<u>Masonry</u>	<u>None</u>	<u>0</u>	<u>0</u>	<u>0</u>	<u>0</u>	<u>4.6</u>	<u>15</u>
	<u>Wired glass with outside sprinklers and 1 hr doors</u>	<u>0</u>	<u>0</u>	<u>3.0</u>	<u>10</u>	<u>6.1</u>	<u>20</u>
	<u>Wired or plain glass with outside sprinklers and ¾ hr doors</u>	<u>3.0</u>	<u>10</u>	<u>6.1</u>	<u>20</u>	<u>9.1</u>	<u>30</u>
<u>Wood or metal with outside sprinklers</u>		<u>3.0</u>	<u>10</u>	<u>6.1</u>	<u>20</u>	<u>9.1</u>	<u>30</u>
<u>Wood, metal or other</u>		<u>6.1</u>	<u>20</u>	<u>9.1</u>	<u>30</u>	<u>15.2</u>	<u>50</u>

*CHAPTER 39 entitled AUTOMOBILE WRECKING YARDS is hereby added to read as follows:*

**CHAPTER 39 AUTOMOBILE WRECKING YARDS**

**3901. Automobile dismantling and storage.**

Nothing but automobile dismantling shall be carried on in any automobile wrecking yard or establishment, and if repairs are made to any automobile or other self-propelled vehicle, such repairs shall be made in a building meeting all the requirements of a public automobile garage or automobile repair shop and in keeping with the regulations for such occupancy.

All gasoline shall be drained from the gasoline reservoirs of all automobiles or other self-propelled vehicles stored or kept on the premises, unless such automobiles or vehicles are in such state of repair as to enable them to be removed from the premises under their own power.

*Section 5003.4.1 Material Safety Data Sheet Submittal is added to read as follows:*

**5003.4.1 Material Safety Data Sheet Submittal.** The Fire Marshal may require that information on the nature of any and all potentially hazardous material be submitted to the Fire Department on the Standard Material Safety Data Sheet

provided by the U.S. Department of Labor Occupational Safety and Health Administration.

*Section 5601.1.3.1 Unlawful Possession of Fireworks, 5601.1.3.2 Instigating or Aiding a Minor to Violate the Ordinance Prohibiting Fireworks, and 5601.1.3.3 Summons to be issued for Violation of Fireworks Ordinance are added to read as follows:*

**5601.1.3.1 Unlawful Possession of Fireworks.** It shall be unlawful for any person to have, keep, store, sell, offer for sale, give away, use, transport or manufacture fireworks or pyrotechnics of all kinds in any quantity, within the corporate limits of the City, or to sell or offer for sale, such fireworks within an area extending 5000 feet beyond the City limits.

**Exception:** A state or federally licensed importer or distributor established within said 5000 foot area prior to the enactment of this section and using area for storage or for distribution to or sale to governmental agencies or federal or state licensees or permittees.

**5601.1.3.2 Instigating or Aiding a Minor to Violate the Ordinance Prohibiting Fireworks.** No person shall furnish money or a thing of value to a minor for the purchase of fireworks or encourage, act in conjunction with or in any manner instigate or aid a minor in the act of having, keeping, storing, selling, offering for sale, giving away, using, transporting, or manufacturing fireworks within or 5000 feet beyond the corporate limits of the City. Such actions shall constitute Class C misdemeanors and be punished by a fine not to exceed \$2,000.00.

**5601.1.3.3 Summons to be issued for Violation of Fireworks Ordinance.** A summons or notice to appear in answer to a charge of illegal possession or use of fireworks in violation of this section specifying the location of such violation, the date and time of such violation, and the name and address of the offender, may be issued by any Police Officer, Arson Investigator, Fire Inspector or by any Firemen who has been assigned to citation duties by the Fire Chief.

*Section 5601.2 Permit required is amended by adding new Sections 5601.2.5 Congested Areas through 5601.2.14 Appeals to the Board of Appeals Concerning Explosives Permits as follows:*

**5601.2.5 Congested Areas.** When explosives or explosive ingredients are stored, handled, used or transported or processed in congested mercantile, industrial, commercial or other heavily populated areas, the explosive permit must be countersigned by the Fire Chief and the Chief of Police or by a person authorized to act for each. No explosive permit for use in these areas shall be valid unless it bears the signature of each of the above-named officials.

**5601.2.6 Prohibited Explosives.** It shall be unlawful for any person to have, keep, store, sell, offer for sale, give away, use, transport or manufacture any of the explosives listed in Section 5601.3 any quantity, within the corporate limits of the City, or to store, sell, use or offer for sale such explosives within 5000 feet beyond the City limits unless authorized by the Fire Marshal.

**5601.2.7 Applicant Qualifications.** Only those persons who have proven to the Fire Marshal by examination or actual test or by check references of three persons not related to the applicant, or by all those means, that they are qualified to manufacture, store, handle, use, transport, or possess explosives and ingredients and who have proved to the satisfaction of the Fire Marshal that they have read, or have had read to them, and understood the provisions of this section shall be given an explosives permit. Applicants who fail the written examination may repeat the exam after 30 days. Those failing the test the second time may retake the test for the third time after 90 days. Persons failing the test three times will not be permitted to repeat test for one year from date of last test taken.

**5601.2.8 Inspection Required.** Upon receipt of an application for a permit, special permit or certificate of fitness as required by this chapter, the Fire Marshal shall make or cause to be made an investigation to determine if all conditions of this article applying to the permit specified are fulfilled, and if the Fire Marshal shall find that the things required to be set forth and are true and that the requirements of this article are fulfilled, the permit or certificate herein mentioned shall be issued.

**5601.2.9 Purpose Specified.** Explosive permit shall specify the purpose for which the explosives or other ingredients are to be manufactured, stored, handled, transported or possessed, and the maximum amount that will be allowed.

**5601.2.10 Application for Permit.**

1. All applications for permits shall be in writing. Every person applying for an explosives permit must appear in person before the Fire Marshal or his authorized representative. Government departments, firms, corporations, partnerships, contractors, or other legal entity may obtain explosive permits through a person authorized to act for or assumed legal responsibility for them.
2. The Fire Marshal shall not issue an explosive permit if he receives a written objection from the City Manager, Chief of Police or from persons authorized to act for them.
3. The Arson Division shall do a computer investigation check based on the information on the application.
4. Every person applying for a permit must be able to read and write the English language.
5. The Fire Marshal or his designate may request written comments on each permit application from the various affected City of San Antonio utilities or franchise holders. When, in the opinion of the Fire Marshal, such utility or franchise holder has a valid objection to the issuance of

a permit, no permit shall be approved until such objection has been resolved to the satisfaction of the Fire Marshal or his designate.

6. When, in the opinion of the Fire Marshal or his designate, there is a substantial danger to life, health, or property in the immediate area exposed to the blasting for which a permit is being requested, said permit may be denied.

**5601.2.11 Records.** Permits shall be numbered consecutively on an annual basis and the Fire Marshal shall keep an accurate and complete record of all explosives permits issued.

**5601.2.12 Permit Limitations.**

1. Explosives Handling Permits may be issued for a period, not to exceed one year from date of issuance, deemed advisable by the Fire Marshal.
2. No employee of a government department, firm, partnership or individual shall be issued an explosives handlers permit unless his employer first obtains an explosives site permit.
3. An employee's explosive permit shall become void if his employer's explosive permit is revoked or expires without being renewed.
4. Permits shall be unassignable and nontransferable, and no person shall operate under, or have the benefit of, another person's permit.
5. The Fire Marshal shall revoke an explosive permit for violation of any of the provisions of this chapter. The offender shall have the right to appeal the Fire Marshal's revocation decision.
6. The death of any permittee, shall, ipso facto, immediately render the permit void, and the personal representative or heirs of the decedent must apply for a permit to cover remaining explosives or ingredients or uncompleted operations requiring a permit. If a permittee is discharged from his employment, his permit shall become immediately void and shall be delivered to his employer, who must deface it by writing across the face thereof the word "Void", together with a notation of the date and reason for the voidance, and thereafter mail or deliver it to the Fire Marshal, and the employer must at once take possession and charge of any explosives or ingredients for which the permittee was accountable. In the event of the dissolution or transfer of the business of any permittee, the successor in interest of the permittee shall immediately apply for a permit to cover any explosives, ingredients or operations relating to same.
7. In the event of the bankruptcy of a permittee, the trustee or receiver of his bankrupt estate shall immediately apply for a permit to cover any remaining explosives, ingredients, or operations relating thereto. The permit shall not pass with any forced sale or other forced transfer of explosives, ingredients, or operations covered by it, and the transferee must immediately apply for a permit to cover same.
8. Any permit that becomes void during the period for which it was issued shall be returned within ten days to the Fire Marshal and it shall be accompanied with all Photostat copies that have been made.



9. The Fire Marshal shall be notified of the loss or destruction of any valid permit.

**5601.2.13 Blasting Site Permits.**

1. Blasting permits shall be issued by the Fire Marshal and shall set forth the name of the contractor or other responsible party applying, the name of the property owner upon whose property the blasting is to be done and the location of the property. Such permit shall be valid and operative for a period not to exceed 90 days from date issued, except for quarry operation permits, which shall be issued for a period not to exceed one year.
2. The Fire Marshal shall not issue a permit for quantities to exceed one hundred pounds of high or low explosives, five hundred electric blasting caps, or 25 pounds of black powder of any kind, without the approval of the Board of Appeals.
3. The Fire Marshal may limit the quantity of explosives or blasting agents to be permitted at any location.
4. The Fire Marshal may defer the issuance of an explosives permit in order to make any such investigation as he deems necessary.

**5601.2.14 Appeals to the Board of Appeals Concerning Explosives Permits.**

Any person who has been refused issuance of an explosive permit or who has had his explosive permit revoked may appeal such action by notifying the chairman of the Building-related and Fire Codes Appeals and Advisory Board in writing within 10 days after he has received notice of such refusal or revocation.

*Section 5602.1 Definitions is amended by adding a definition as follows:*

**5602.1 Definitions.** The following words and terms shall, for the purposes of this chapter and as used elsewhere in this code, have the meanings shown herein.

HIGHWINDS. Sustained wind velocity of 15 mph or gusts of 25 mph.

*Section 5607.1 General is amended by adding Section 5607.1.1 Conditions of Approval as follows:*

**5607.1.1 Conditions of Approval.** The Fire Marshal shall set other conditions to the approval of a permit application that are necessary, in his opinion, to adequately protect the public health and safety. These conditions may include, but are not limited to, reduced allowable particle velocities, additional monitoring, increased insurance protection, hours of operation, type and amount of explosives used and engineered blasting plans.

*Section 5607.4 Restricted hours is amended to read as follows:*

**5607.4 Restricted hours.** Except by written approval by the Fire Marshal, no blasting operations shall be conducted on Saturdays, Sundays or legal holidays or between the hours of 5:00 p.m. and 8:00 a.m. [~~Surface blasting operations shall only be conducted during daylight hours between sunrise and sunset. Other blasting shall be performed during daylight hours unless otherwise approved by the fire code official.~~]

*Section 5607.14 Post-blast procedures is amended by adding Section 5607.14.1 Removal of Equipment as follows:*

**5607.14.1 Removal of Equipment.** All exposed blasting cap lead wires in the ground from previous shots shall be removed at the end of the workday.

*SECTION 5607 BLASTING is amended by adding Sections 5607.16 Particle Velocity Permitted through 5607.20 Detonating Cord as follows:*

**5607.16 Particle Velocity Permitted.** A particle velocity of 1.7 inches per second will be the maximum velocity allowed by permit. One and seven-tenths (1.7) inches per second particle velocity or above will require the immediate suspension of blasting and corrective procedures implemented to reduce the excess velocity. The Fire Marshal may grant or require variances from this limit to adequately protect the public safety.

**5607.17 Blast Monitor Required.** A blast monitor, such as a seismic blast-recording machine, is required in connection with all permits issued inside the City limits of San Antonio unless specifically exempted by the Fire Marshal. Recordings shall comply with Bureau of Mines Standards for safety and property protection.

**5607.18 Trunk Wire Requirements.** Only blasting trunk wire of 18 gauge minimum will be used while conducting blasting operations by permits.

**5607.19 Approved Equipment Required.** Only approved blasting machines may be used. Car, truck, motorcycle, boat batteries, or power lines are prohibited as being unsafe.

**5607.20 Detonating Cord.** Detonating cord may be used only when approved on the blasting permit. Unauthorized use of detonating cord shall result in the suspension of the blasting permit and/or blaster's license.

*Section 5608.1 General is amended by adding Sections 5608.1.1 Public Displays - Duties of the Operator through 5608.1.5 Fire Inspectors to be Present as follows:*

**5608.1.1 Public Displays - Duties of the Operator.** The operator of a public fireworks display shall comply with the following:

1. The minimum radius of the secured area surrounding a fireworks display (the minimum safe distance between the mortar site and

spectators) shall be 70 feet per shell inch of the largest shell to be fired. Spectators shall be restrained using a barrier approved by the Fire Marshal. Security officers shall be provided and assigned as approved by the Fire Marshal.

2. Fire projectiles:
  - (a) So that the range of aerial display shall be not more than 200 feet and the fireworks shall be discharged vertically from steel or other approved tubes; or
  - (b) So that they will impact in a body of water;
3. Maintain an unobstructed spatial separation of:
  - (a) 600 feet between the ignition point and a school;
  - (b) 200 feet between the ignition point and a highway, railroad, or building other than a school; and
  - (c) 50 feet between the ignition point and an overhead obstruction.
4. Discontinue the display if the wind carries fireworks debris to adjoining property; and
5. Immediately after display:
  - (a) Search the display site for unfired fireworks or fireworks debris; and
  - (b) Safely dispose of any unfired fireworks or fireworks debris in the prescribed by the Fire Marshal.

**5608.1.2 Fireworks Permits.** Possession and use of fireworks and pyrotechnics shall be allowed in connection with a fireworks display in celebration of a recognized holiday under the following conditions:

1. The site of the display has been previously approved by the Fire Marshal;
2. The display is within 10 days of a federal, state or city holiday, and is in connection with a public holiday celebration;
3. The display is to be held under the supervision of the Fire Marshal or his representative. In addition to other violations contained in this chapter, it shall be unlawful for any person in conducting such a display, or storing or moving explosives preparatory to such an event, to fail to adhere to all specifications and directions of the Fire Department representative supervising such event.

**5608.1.3 Materials Not to be Stored in City.** The material to be used for a public display authorized by this division shall not be stored within the City limits, but shall be brought in on the day of the public display and then shall be taken immediately to the place of display for further handling and storage.

**5608.1.4 Limitation on Time and Number of Displays.** No display authorized by this division shall be commenced prior to the hour of 1:00 P.M. nor later than 10:00 P.M. Sundays through Thursdays and no later than 11:00 P.M. on Fridays and Saturdays.; however, fireworks displays may be commenced between the hours of 10:00 P.M. on December 31 of any year and between the hours of midnight and 1:00 A.M. on January 1 of any year if such displays comply with all

other requirements of this code. Any display authorized by this division shall be completed within one hour after the time the display is commenced, and no permit shall authorize more than two displays in each 24 hours.

**5608.1.5 Fire Inspectors to be Present.** For each public display of fireworks under this division, not less than two Fire Prevention officers of the city shall be in attendance during the display. If more than two fire inspectors are required or the inspector's work takes longer than two hours, the additional expense shall be borne by the applicant for the permit at the rate per man-hour as provided for in Section 11-16(k) of the City Code. The Fire Chief may require standby firefighting unit at the expense of the applicant.

*Section 5608.2.2 Use of pyrotechnics before a proximate audience is amended by adding Section 5608.2.2.1 Inside Use of Pyrotechnics as follows:*

**5608.2.2.1 Inside Use of Pyrotechnics.** The use of pyrotechnics inside of a building shall be unlawful unless authorized and approved in writing by the Fire Marshal prior to the issuance of a permit. The Fire Marshal may require the owner or person in possession or control of the building or premises to provide without charge to the department a technical opinion and report stating whether harmful smoke would be produced and pose a health hazard to the public. The opinion and report shall be prepared by a qualified engineer, specialist, laboratory, or fire safety specialty organization acceptable to the Fire Marshal and the owner. A permit for the use of pyrotechnics shall be issued when approved by the Fire Marshal. Application for a permit shall be made in writing 10 days prior to the use of pyrotechnics.

*Section 5608.2 Permit application is amended by adding Sections 5608.2.3 Procedure for Applying; Permit for Fireworks Display through 5608.2.8 Duties of Permittee as follows:*

**5608.2.3 Procedure for Applying; Permit for Fireworks Display.**

A permit applicant shall, at least 10 days before using fireworks, file with the Fire Marshal a completed permit application showing the:

1. Pyrotechnics:
  - (a) Business address;
  - (b) Proof of legal competency; and
  - (c) Record of previous experience with fireworks;
2. Address of the proposed display;
3. Amount, type, and class of fireworks to be used;
4. Address of the company supplying the fireworks;
5. Date of proposed display;
6. Starting and ending times of the proposed display; and
7. Diagram of the proposed display grounds, detailing:
  - (a) Firing points
  - (b) Location of buildings and highways on or adjoining the grounds;
  - (c) Spectator restraining lines; and

(d) Overhead obstructions.

8. Completed permit application to the Fire Marshal including the surety bond or insurance coverage required by State Law.

The Fire Marshal shall, within five days from date of the completion of the requirements in Subsection (l) of this section, approve or refuse to approve the permit. If the Fire Marshal refuses to approve issuance, he shall immediately send to the applicant by certified mail, return receipt requested, a written statement explaining the basis of the refusal.

The permittee shall notify in writing, at least 48 hours prior to consideration by the Fire Marshal, all residents within 1000 feet of a proposed fireworks site.

**5608.2.4 Refusal to Issue.** The Fire Marshal may refuse to approve issuance of a permit if the applicant:

1. Intentionally makes a false statement as to a material matter in the permit application;
2. Is a fugitive from justice;
3. Is under a felony indictment;
4. Has been finally convicted of a felony offense within that five year period immediately preceding the filing of the application;
5. Has been finally convicted of a misdemeanor violation of an explosives law or regulation within the two year period immediately preceding filing of the application;
6. Held a permit issued under this article, which permit was revoked within that one year period immediately preceding the filing of the application;
7. Has been adjudicated a mental defective; is an unlawful user of, or addicted to, a controlled substance or dangerous drug, or suffers from any other handicap, infirmity, defect, or condition which might reasonably diminish his competency to safely conduct the proposed activity or would create an unreasonable risk of injury to life or property in the performance of the proposed activity.

**5608.2.5 Revocation of Permit.** The Fire Marshal shall revoke a permit if the permittee:

1. Intentionally makes a false statement as to a material matter in the permit application;
2. Knowingly allows another to use his permit;
3. Violates a term or condition of the permit;
4. Fails within the applicable time period to comply with an order or notice on him under this article; or

5. Fails to discharge a duty imposed on him by this Section.

The Fire Marshal shall, within five days from the date of revocation, send to the permittee by certified mail, return receipt requested, a written statement explaining the basis of the revocation.

**5608.2.6 Appeal of Permit Refusal or Revocation.** If the Fire Marshal refuses to issue a permit under this section, that action is final unless the applicant or permittee, within 10 days after receiving a written notice of the action, files a written appeal with the chairman of the Board of Appeals.

**5608.2.7 Bond.** The permittee shall furnish a bond or certificate of insurance in the minimum amount of one million dollars. The Fire Marshal may increase the amount of the required bond or insurance when he deems it advisable.

**5608.2.8 Duties of Permittee.** A permittee shall:

1. Upon request, make his permit available for inspection to a member of the Fire Department, Police Officer, or any other authorized person;
2. Notify the Fire Marshal of the loss or destruction of an unexpired permit, notice to be given immediately upon discovery of the loss or destruction;
3. Secure a replacement permit for that lost or destroyed;
4. Comply immediately with the Fire Marshal's order to dispose of fireworks which become hazardous during the performance of this permitted activity; and
5. Return his permit to the Fire Marshal immediately upon its expiration, together with a statement detailing the cause of expiration and the disposition of unused fireworks.

*Section 5701.4 Permits is amended by adding Section 5701.4.1 Permit Required Prior to Installation as follows:*

**5701.4.1 Permit Required Prior to Installation.** Permit to install tanks shall be applied for to the Fire Department before installation is begun. Application for permit shall be accompanied by construction documents in accordance with section 105.4. Applications for installation over the Edward's Aquifer shall be reviewed by the Aquifer Study Division of the San Antonio Water System prior to submittal to the Fire Department for a permit.

*Section 5703.6 Piping systems is amended by adding Section 5703.6.12 Pressurized Piping as follows:*

**5703.6.12 Pressurized Piping.** Where a pressurized (remote pumped) piping system is connected to a tank, the piping system shall have an approved leak detection device installed in the system to monitor for leaks in the piping.

*Section 5704.2.11.4.2 Leak Detection is amended by adding the approved methods to read as follows:*

**5704.2.11.4.2 Leak Detection.** Underground storage tank systems shall be provided with an *approved* method of leak detection from any component of the system that is designed and installed in accordance with NFPA 30. The following are approved methods of leak detection:

1. Manual tank gauging (for tanks less than 1,000 gallons);
2. Automatic tank gauging and inventory control;
3. Vapor monitoring;
4. Groundwater monitoring;
5. Interstitial Monitoring of double-wall systems;
6. Monitoring of systems with secondary containment barriers;
7. Statistical Inventory Reconciliation (SIR) - (for tanks and lines)  
NOTE: Documentation of performance claims for the SIR method must show the system's ability to detect releases of 0.1 g.p.h. with 95% or more probability of detection and five percent or less probability of false alarm.

*Section 5704.2.12.2 Testing of underground tanks is amended to read as follows:*

**5704.2.12.2 Testing of underground tanks.** Before being covered or placed in use, tanks and piping connected to underground tanks shall be tested for tightness in the presence of the *fire code official*. Piping shall be tested in accordance with Section 5703.6.3. The system shall not be covered until it has been *approved*. Each tank shall be tested for tightness hydrostatically or pneumatically at not less than three pounds per square inch or not more than five pounds per square inch for 60 minutes. Pneumatic testing shall not be used on a tank containing flammable or combustible liquids or vapors.

*Section 5704.2.12.2 Testing of underground tanks is amended by adding Sections 5704.2.12.2.1 Existing Tanks and Piping and 5704.2.12.2.2 Alternate Test Method as follows:*

**5704.2.12.2.1 Existing Tanks and Piping.** Existing underground storage tanks and piping shall be tested for leakage every five years at the owner's or operator's expense or when the Fire Marshal has reasonable cause to believe a leak exists. A log or record shall be kept and the log shall be made available for inspection by the Fire Marshal when requested. Notice of test shall be provided in writing to the Fire Marshal by the owner or operator.

**5704.2.12.2.2 Alternate Test Method.** The Fire Marshal may require that the standpipe method of testing for tank leaks be utilized if in the Fire Marshal's opinion the air pressured tests would be unlikely to detect a leak, cause damage to tank or cause expulsion of contained liquids.

*Section 6107: Safety Precautions and Devices is hereby amended as follows:*

**6107.4 Protecting containers from vehicles.** Where exposed to vehicular damage due to proximity to alleys, driveways or parking areas, LP-gas containers, regulators and piping shall be protected in accordance with Section 312 Vehicle Impact Protection [NFPA-58].

*Chapter 80, REFERENCED STANDARDS, is hereby amended by adding the following referenced standard:*

**NFPA 90A-15 Standard for the Installation of Air-Conditioning and Ventilating Systems**

*Appendix B, FIRE-FLOW REQUIREMENTS FOR BUILDINGS, Section B104.2 Area Separation is amended by adding the following exceptions:*

**B104.2 Area Separation.** Portions of buildings which are separated by fire walls without openings, constructed in accordance with the International Building Code, are allowed to be considered as separate fire-flow calculation areas.

**Exceptions**

- 1: Fire-flow calculation area for open parking garages shall be determined by the area of the largest floor.
2. Where building additions are protected with an approved automatic sprinkler system and separated from the existing building by an approved Fire Barrier with minimum fire resistance ratings and protected openings as per the International Building Code, fire areas may be considered as separate.

*Appendix B, FIRE-FLOW REQUIREMENTS FOR BUILDINGS, Section B105, Fire-Flow Requirements for Buildings is hereby repealed in its entirety and replaced with the following:*

**B105.1 One- and two-family dwellings.** The minimum fire-flow and flow duration requirements for one- and two-family *dwellings* having a fire-flow calculation area that does not exceed 3,600 square feet (344.5 m<sup>2</sup>) shall be 1,000 gallons per minute (3785.4 L/min) for 1 hour. Fire-flow and flow duration for



dwellings having a fire-flow calculation area in excess of 3,600 square feet (344.5m<sup>2</sup>) shall not be less than that specified in Table B105.1.

**Exception:** A reduction in required fire-flow of 50 percent, as *approved*, is allowed when the building is equipped with an *approved automatic sprinkler system*.

**B105.2 Buildings other than one-and -two family dwellings.** The minimum fire-flow and flow duration for buildings other than one- and two-family dwellings shall be as specified in Table B105.1.

**Exception 1.** Buildings equipped throughout with an approved automatic sprinkler system in accordance with Sections 903.3.1.1, 903.3.1.2, or 903.3.1.3 shall qualify for a reduction in the required fire flow according to Table B105.2 below. Note also the minimum and maximum fire flows listed in the table for the fully sprinklered occupancies listed.

**Exception 2.** Non-fire sprinklered, non-combustible open parking garages meeting the requirements of the 2015 International Building Code Section 406.3 shall have a maximum required fire flow of 2,200 gpm.

**TABLE B105.1 MINIMUM REQUIRED FIRE-FLOW AND FLOW DURATION FOR BUILDINGS**

<b>FIRE-FLOW CALCULATION AREA (square feet)</b>					<b>FIRE-FLOW</b>	<b>FLOW</b>
<b>Type IA and IB<sup>a</sup></b>	<b>Type IIA and IIIA<sup>a</sup></b>	<b>Type IV and V-A<sup>a</sup></b>	<b>Type IIB and IIIB<sup>a</sup></b>	<b>Type V-B<sup>a</sup></b>	<b>(gallons per minute)<sup>b</sup></b>	<b>DURATION (hours)</b>
0-22,700	0-12,700	0-8,200	0-5,900	0-3,600	1,500	2
22,701-30,200	12,701-17,000	8,201-10,900	5,901-7,900	3,601-4,800	1,750	
30,201-38,700	17,001-21,800	10,901-12,900	7,901-9,800	4,801-6,200	2,000	
38,701-48,300	21,801-24,200	12,901-17,400	9,801-12,600	6,201-7,700	2,250	
48,301-59,000	24,201-33,200	17,401-21,300	12,601-15,400	7,701-9,400	2,500	
59,001-70,900	33,201-39,700	21,301-25,500	15,401-18,400	9,401-11,300	2,750	
70,901-83,700	39,701-47,100	25,501-30,100	18,401-21,800	11,301-13,400	3,000	3
83,701-97,700	47,101-54,900	30,101-35,200	21,801-25,900	13,401-15,600	3,250	
97,701-112,700	54,901-63,400	35,201-40,600	25,901-29,300	15,601-18,000	3,500	
112,701-128,700	63,401-72,400	40,601-46,400	29,301-33,500	18,001-20,600	3,750	
128,701-145,900	72,401-82,100	46,401-52,500	33,501-37,900	20,601-23,300	4,000	4

<u>145,901-164,200</u>	<u>82,101-92,400</u>	<u>52,501-59,100</u>	<u>37,901-42,700</u>	<u>23,301-26,300</u>	<u>4,250</u>
<u>164,201-183,400</u>	<u>92,401-103,100</u>	<u>59,101-66,000</u>	<u>42,701-47,700</u>	<u>26,301-29,300</u>	<u>4,500</u>
<u>183,401-203,700</u>	<u>103,101-114,600</u>	<u>66,001-73,300</u>	<u>47,701-53,000</u>	<u>29,301-32,600</u>	<u>4,750</u>
<u>203,701-225,200</u>	<u>114,601-126,700</u>	<u>73,301-81,100</u>	<u>53,001-58,600</u>	<u>32,601-36,000</u>	<u>5,000</u>
<u>225,201-247,700</u>	<u>126,701-139,400</u>	<u>81,101-89,200</u>	<u>58,601-65,400</u>	<u>36,001-39,600</u>	<u>5,250</u>
<u>247,701-271,200</u>	<u>139,401-152,600</u>	<u>89,201-97,700</u>	<u>65,401-70,600</u>	<u>39,601-43,400</u>	<u>5,500</u>
<u>271,201-295,900</u>	<u>152,601-166,500</u>	<u>97,701-106,500</u>	<u>70,601-77,000</u>	<u>43,401-47,400</u>	<u>5,750</u>
<u>295,901-Greater</u>	<u>166,501-Greater</u>	<u>106,501-115,800</u>	<u>77,001-83,700</u>	<u>47,401-51,500</u>	<u>6,000</u>
=	=	<u>115,801-125,500</u>	<u>83,701-90,600</u>	<u>51,501-55,700</u>	<u>6,250</u>
=	=	<u>125,501-135,500</u>	<u>90,601-97,900</u>	<u>55,701-60,200</u>	<u>6,500</u>
=	=	<u>135,501-145,800</u>	<u>97,901-106,800</u>	<u>60,201-64,800</u>	<u>6,750</u>
=	=	<u>145,801-156,700</u>	<u>106,801-113,200</u>	<u>64,801-69,600</u>	<u>7,000</u>
=	=	<u>156,701-167,900</u>	<u>113,201-121,300</u>	<u>69,601-74,600</u>	<u>7,250</u>
=	=	<u>167,901-179,400</u>	<u>121,301-129,600</u>	<u>74,601-79,800</u>	<u>7,500</u>
=	=	<u>179,401-191,400</u>	<u>129,601-138,300</u>	<u>79,801-85,100</u>	<u>7,750</u>
=	=	<u>191,401-Greater</u>	<u>138,301-Greater</u>	<u>85,101-Greater</u>	<u>8,000</u>

For SI: 1 square foot = 0.0929 m<sup>2</sup>, 1 gallon per minute = 3.785 L/m, 1 pound per square inch = 6.895 kPa.

- a. Types of construction are based on the *International Building Code*.
- b. Measured at 20 psi residual pressure.

**Table B105.2**—Fire flow reductions for fully sprinklered buildings

<u>Construction Type</u>	<u>Occupancy Type<sup>4, 5</sup></u>	<u>% Reduction</u>	<u>Minimum (gpm)</u>	<u>Maximum (gpm)</u>
All	A	75	1,500	2,000
VB, IIIB, IIB	B	50	1,500	2,200
All Others	B	50	1,500	2,000

<u>All</u>	<u>E</u>	<u>75</u>	<u>1,500</u>	<u>2,000</u>
<u>VB, IIIB, IIB</u>	<u>F</u>	<u>50</u>	<u>1,500</u>	<u>2,200</u>
<u>All Others</u>	<u>F</u>	<u>50</u>	<u>1,500</u>	<u>2,000</u>
<u>All</u>	<u>H-1</u>	<u>See Footnotes</u>	<u>1,500</u>	<u>See Footnotes</u>
<u>All</u>	<u>H-2</u>	<u>See Footnotes</u>	<u>1,500</u>	<u>See Footnotes</u>
<u>All</u>	<u>H-3</u>	<u>See Footnotes</u>	<u>1,500</u>	<u>See Footnotes</u>
<u>All</u>	<u>H-4</u>	<u>See Footnotes</u>	<u>1,500</u>	<u>See Footnotes</u>
<u>All</u>	<u>H-5</u>	<u>See Footnotes</u>	<u>1,500</u>	<u>See Footnotes</u>
<u>All</u>	<u>I</u>	<u>75</u>	<u>1,500</u>	<u>2,000</u>
<u>VB, IIIB, IIB</u>	<u>M</u>	<u>50</u>	<u>1,500</u>	<u>2,200</u>
<u>All Others</u>	<u>M</u>	<u>50</u>	<u>1,500</u>	<u>2,000</u>
<u>All</u>	<u>R</u>	<u>50</u>	<u>1,500</u>	<u>2,000</u>
<u>All except VB2</u>	<u>S-1 not high piled</u>	<u>50</u>	<u>1,500</u>	<u>2,200</u>
<u>All except VB2</u>	<u>S-1 high piled Class I-IV commodities, ≤ 12,000 sq ft.</u>	<u>Greater of Approved Sprinkler Demand<sup>3</sup> (ASD) or 1,500 gpm</u>		
<u>All except VB2</u>	<u>S-1 high piled Class I-IV commodities, &gt;12,000 sq ft</u>	<u>Greater of 2,200 gpm or the ASD + 25%</u>		
<u>All except VB2</u>	<u>S-1 high piled Class V commodities, ≤ 2,500 sq ft.</u>	<u>Greater of 1,500 gpm or the ASD</u>		
<u>All except VB2</u>	<u>S-1 high piled Class V commodities, 2,501-6,000 sq ft</u>	<u>Greater of 1,500 gpm or the ASD + 500 gpm</u>		
<u>All except VB2</u>	<u>S-1 high piled Class V commodities, &gt;6,000 sq ft</u>	<u>Greater of 2,200 gpm or the ASD + 1,000 gpm</u>		
<u>All except VB2</u>	<u>S-1 Aircraft Hangers, Helistops</u>	<u>50</u>	<u>1,500</u>	<u>2,200</u>
<u>All except VB2</u>	<u>S-2</u>	<u>50</u>	<u>1,500</u>	<u>2,200</u>

**Footnotes:**

1. As determined by Fire Marshal on a case by case basis.
2. These occupancies that are constructed of Type VB construction shall not be granted a reduction in the required fire flow due to the installation of a fire sprinkler system.
3. Approved sprinkler demand (ASD) is the sprinkler demand as defined in NFPA or other nationally recognized standards and includes the hose stream demand. When multiple sprinkler systems are in one building, the approved sprinkler demand shall be the greatest sprinkler demand (including hose stream demand).
4. Occupancies containing High Piled Combustible Storage as defined in Chapter 32 shall be evaluated using the criteria for S-1 occupancies.
5. Mixed-use occupancies shall be evaluated for the most restrictive occupancy present in the building.

*Appendix C, FIRE HYDRANT LOCATIONS AND DISTRIBUTION is hereby amended by amending Table C102.1 Required Number and Spacing of Fire Hydrants by deleting the Average Spacing Between Hydrants and Maximum Distance from Any Point on Street or Road Frontage to a Hydrant columns of the chart and deleting Notes “f” and “g” to read as follows:*

**TABLE C102.1 Number and Distribution of Fire Hydrants**

<b>PRE-FLOW REQUIREMENT (gpm)</b>	<b>MINIMUM NUMBER OF HYDRANTS</b>	<b>AVERAGE SPACING BETWEEN HYDRANTS<sup>a,b,e</sup></b>	<b>MAXIMUM DISTANCE FROM ANY POINT ON STREET OR ROAD FRONTAGE TO A HYDRANT<sup>d</sup></b>
1,750 or less	1	500	250
2,000-2,250	2	450	225
2,500	3	450	225
3,000	3	400	225
3,500-4,000	4	350	210
4,500-5,000	5	300	180
5,500	6	300	180
6,000	6	250	150
6,500-7,000	7	250	150
7,500 or more	8 or more	200	120

For SI: 1foot= 304.8 mm, 1 gallon per minute = 3.785L/m.

a. Reduce by 100 feet for dead-end streets or roads.

b. Where streets are provided with median dividers which cannot be crossed by fire fighters pulling hose lines, or where arterial streets are provided with four or more traffic lanes and have a traffic count of more than 30,000 vehicles per day, hydrant spacing shall average 500 feet on each side of the street and be arranged on an alternating basis up to a fire-flow requirement of

7,000 gallons per minute and 400 feet for higher fire-flow requirements.

c. Where new water mains are extended along streets where hydrants are not needed for protection of structures of similar fire problems, fire hydrants shall be provided at spacing not to exceed 1,000 feet to provide for transportation hazards.

d. Reduce by 50 feet for dead-end streets or roads.

e. One hydrant for each 1,000 gallons per minute or fraction thereof

[f. A 50-percent spacing increase shall be permitted where the building is equipped throughout with an approved automatic sprinkler system in accordance with Section 903.3.1.1 of the *International Fire Code*.

g. A 25-percent spacing increase shall be permitted where the building is equipped throughout with an approved automatic sprinkler system in accordance with Section 903.3.1.3 of the *International Fire Code* or Section P2904 of the *International Residential Code*.]

*Appendix D, FIRE APPARATUS ACCESS ROADS is hereby amended by amending Section D103.5 Fire Apparatus access road gates, repealing Section D103.6 Signs and adding a new Section D103.6 Signs to read as follows:*

**D103.5 Fire apparatus access road gates.** Gates securing the fire apparatus access roads shall comply with all of the following criteria:

1. Where a single gate is provided, the gate width shall be not less than 20 feet (6096 mm). Where a fire apparatus road consists of a divided roadway, the gate width shall be not less than 14 feet [~~12 feet (3658 mm)~~].
2. Gates shall be of the swinging or sliding type.

3. Construction of gates shall be of materials that allow manual operation by one person.
4. Gate components shall be maintained in an operative condition at all times and replaced or repaired when defective.
5. Electric gates shall be equipped with a means of opening the gate by fire department personnel for emergency access. Emergency opening devices shall be *approved* by the *fire code official*.
6. Methods of locking shall be submitted for approval by the *fire code official*.
7. Electric gate operators, where provided, shall be *listed* in accordance with UL 325.
8. Gates intended for automatic operation shall be designed, constructed and installed to comply with the requirements of ASTM F 2200.

### **D103.6 Signs.**

**D103.6.1 Roads 20 to 26 feet in width.** Fire lane signs in accordance with Section 503.3 of this code shall be posted on both sides of fire apparatus access roads that are 20 to 26 feet wide (6096 to 7925 mm).

**D103.6.2 Roads more than 26 feet in width.** Fire lane signs in accordance with Section 503.3 of this code shall be posted on one side of fire apparatus access roads more than 26 feet wide (7925 mm) and less than 32 feet wide (9754 mm).

*Appendix D FIRE APPARATUS ACCESS ROADS is hereby amended by deleting Section D104.1 Building exceeding three stories or 30 feet in height.*

~~[D104.1 Building exceeding three stories or 30 feet in height. Buildings or facilities exceeding 30 feet (9144 mm) or three stories in height shall have at least two means of fire apparatus access for each structure.]~~

*Appendix D105 AERIAL FIRE APPARATUS ACCESS ROADS is hereby amended by adding exceptions to both D105.1 Where required and D105.2 Width and modifying the maximum distance an access route may be located from the building in D105.3 Proximity to building as follows:*

**D105.1 Where required.** Where the vertical distance between the grade plane and the highest roof surface exceeds 30 feet (9144 mm), approved aerial fire apparatus access roads shall be provided. For the purposes of this section, the highest roof surface shall be determined by measurement to the eave of a pitched roof, the intersection of the roof to the exterior wall, or the top of parapet walls, whichever is greater.

### **Exceptions:**

1. In other than Group R only buildings, aerial fire apparatus access roads per this section are not required where all of the following conditions are met:
  - a. the building is equipped throughout with an approved automatic sprinkler system in accordance with Section 903.3.1.1 and
  - b. roof access from an enclosed stairwell is provided for buildings 2 or more stories in height. Stairwell must be contiguous from the lowest level of fire department vehicle access to the roof and designed in accordance with the 2015 International Building Code and
  - c. any required fire apparatus access roads and fire lanes are designed with a minimum 25 foot width and provided throughout the platted property.
  
2. In Group R only buildings, aerial fire apparatus access roads per this section are not required where all of the following conditions are met:
  - a. the building is no more than four stories in height, and
  - b. the building is protected by an approved automatic sprinkler system in accordance with Section 903.3.1, and
  - c. the building meets the allowable area provisions of Chapter 5 of the *International Building Code* **without** the use of the area increase factor due to sprinkler protection. (Note: Refer to IBC Equation 5-1.)

**D105.2 Width.** Aerial fire apparatus access roads shall have a minimum unobstructed width of 26 feet, exclusive of shoulders, in the immediate vicinity of the building or portion thereof.

**Exception:** An aerial apparatus access lane may be less than twenty-six (26)ft wide where a minimum 25ft wide fire lane or fire apparatus access road is provided throughout the platted property.

**D105.3 Proximity to building.** At least one of the required access routes meeting this condition shall be located within a minimum of 15 feet [~~(4572 mm)~~] and a maximum of 39 feet [30 feet (9144 mm)] from the building. [~~and shall be positioned parallel to one entire side of the building. The side of the building on which the aerial fire apparatus access road is positioned shall be approved by the fire code official.~~] The road shall be positioned parallel to the side(s) where the aerial access equipment will have maximum use and access by the fire department. The side of the building on which the aerial fire apparatus access road is positioned shall be approved by the *fire code official*. The length of the aerial apparatus road shall total at least one of the following:

1. The entire length of one side of the building provided the length is a minimum of 50 feet, or
2. 25% of the entire building perimeter.

*Appendix D FIRE APPARATUS ACCESS ROADS is hereby amended by adding section D106.3 Separate Access Roads to read as follows:*

**D106.3 Separate Access Roads.** The requirement for two separate and approved fire apparatus access roads are met with the following conditions:

1. A minimum of two separate entrances into the complex are made from the street or public way.
2. The distance between the two entrances are equal to not less than one half the length of the maximum overall diagonal dimension of the property or area to be served, measured in a straight line between accesses, as per 2015 IFC, section D104.3.

**Exception:** Where it is physically impossible to be one-half the diagonal dimension apart, the access road will be approved if the following conditions are met:

- a. The two separate fire apparatus access road must be separated as far as physically and practically possible.
  - b. The two separate entrances must be a minimum of 150 feet apart measured in a straight line between accesses.
3. The two separate entrances are allowed to share a common path of travel on the complex site so long as blockage in any one area of this path does not block access from both the primary and secondary access simultaneously. Each of the two separate fire apparatus roads shall meet the requirements of the 2015 IFC, section 503, Fire Apparatus Access Roads.

**SECTION 4.** Chapter 16, Article I, Section 16-3 (a) is hereby amended as follows:

**Sec. 16-3. Application/permit fee for facilities using hazardous materials; response fee based on materials and man-hours required at scene of accident.**

- (a) An annual permit fee is hereby imposed on every person or corporation that owns, operates, or acts as the agent for any business location where one or more hazardous materials are used, stored, transported, manufactured, generated, disposed or sold within the city, in the fee amounts and for the types of businesses or activities and for the quantities of chemical listed in table I. Businesses and/or locations utilizing, storing, transporting, manufacturing, disposing of, or selling hazardous materials in quantities in

excess of the operational permitting requirements of the Code of Ordinances of the City of San Antonio, Part II-Code, Chapter 11 Fire Prevention Code are subject to the provisions of this section.

**SECTION 5.** All previous provisions of the 2012 International Fire Code with local amendments as adopted by the City of San Antonio, Texas, remain in full force and effect during the period enacted.

**SECTION 6.** Should any Article, Section, Part, Paragraph, Sentence, Phrase, Clause, or Word of this ordinance, or any appendix, for any reason be held illegal, inoperative, or invalid, or if any exception to or limitation upon any general provision in this Ordinance be held to be unconstitutional or invalid or ineffective, the remainder shall, nevertheless, stand effective and valid as if it had been enacted and ordained without the portion held to be unconstitutional or invalid or ineffective.

**SECTION 7.** There is no financial impact as a result of the passage of this ordinance.

**SECTION 8.** No other provision of the City Code is amended by this Ordinance. All other provisions remain in effect.

**SECTION 9.** The City Clerk for the City of San Antonio is directed to publish notice of this Ordinance in a newspaper published in the City of San Antonio, Texas, as required by Article 2, Section 17 of the City Charter of San Antonio, Texas.

**SECTION 10.** The publishers of the City Code of San Antonio are authorized to amend said Code to reflect the changes adopted in this Ordinance, to correct typographical errors and to index, format and number paragraphs to conform to the existing code.

**SECTION 11.** This Ordinance is effective the 1<sup>st</sup> day of May, 2015.

**PASSED AND APPROVED** this 29<sup>th</sup> day of January, 2015.

**M A Y O R**  
Ivy R. Taylor

**Attest:**

**Approved As To Form:**

\_\_\_\_\_  
Leticia M. Vacek, City Clerk

\_\_\_\_\_  
Martha G. Sepeda, Acting City Attorney