

HISTORIC AND DESIGN REVIEW COMMISSION

May 15, 2019

HDRC CASE NO: 2019-262
ADDRESS: 227 DWYER AVE
LEGAL DESCRIPTION: NCB 173 BLK 2 LOT 1 (HERITAGE PLAZA)
ZONING: D
CITY COUNCIL DIST.: 1
APPLICANT: Jim West/GFF
OWNER: Ricky DeCamps/DELTA MAIN & DWYER LLC
TYPE OF WORK: Modification to a previously approved design in regards to windows
APPLICATION RECEIVED: April 29, 2019
60-DAY REVIEW: June 28, 2019
CASE MANAGER: Edward Hall

REQUEST:

The applicant is requesting a Certificate of Appropriateness for approval to amend a previously approved design. New construction was approved at this location on May 17, 2017. Modifications to the original design were approved by the HDRC, with the addresses of 307 Dwyer and 410 S Main. The applicant has requested the following items:

1. Modify the previously approved window installation depths to not feature a recess of two (2) inches.
2. Modify the previously approved façade tile design.

APPLICABLE CITATIONS:

City of San Antonio Downtown Design Guide:

Required Design Standards

Chapter 2: Sidewalks and Setbacks

- A.1. Provide a minimum 72 inch wide continuous pedestrian path of travel as seen in Figure 2.1.
- A.4. Provide continuous landscaped and hardscaped area, commonly referred to as “parkway,” adjacent to the curb on predominantly non-commercial streets.
- A.7. Trees shall be planted in tree wells within tree grates that are at least 5 feet long and a minimum of 5’ feet wide.

Chapter 3: Ground Floor Treatment

- A.1. Locate active uses along the street façade to enhance the building’s relationship to the public realm. Uses include: lobbies, dining rooms, seating areas, offices, retail stores, community or institutional uses, and residences.
- A.5. Clear glass for wall openings, i.e., doors and windows, shall be used along all street-level commercial façades for maximum transparency, especially in conjunction with retail and hotel uses as illustrated in Figure 3.3. Dark tinted, reflective or opaque glazing is not permitted for any required wall opening along commercial street level facades.
- A.6. A building’s primary entrance, defined as the entrance which provides the most direct access to a building’s main lobby and is kept unlocked during business hours, shall be located on a public street or on a courtyard, plaza or paseo that is connected to and visible from a public street or the River Walk.
- A.7. At least one building entrance/exit, which may be either a building or tenant and resident entrance, shall be provided along each street frontage.
- B.1. Awnings and canopies shall be fabricated of woven fabric, glass, metal or other permanent material compatible with the building’s architecture.

Chapter 4: Parking and Access

- A.1. Locate off-street parking behind or below buildings as seen in Figure 4.2 and 4.3.
- A.9. Vehicular access shall be from an alley, sidewalk or mid-block on a street as illustrated in Figure 4.5.
- A.10. Curb cuts and parking and loading entries into buildings shall be limited to the minimum number required and the minimum width permitted.
- A.11. Where a vehicular exit from a parking structure is located within five (5) feet of the back of sidewalk, a visual and audible alarm and enhanced paving shall be installed to warn pedestrians and cyclists of exiting vehicles.
- B.1. Parking structures shall have an external skin designed to improve visual character when exposed to prominent public view. This can include heavy-gage metal screen, pre-cast concrete panels; live green wall (landscaped) laminated glass or photovoltaic panels. Figure 4.6 illustrates an unacceptable external skin.

Chapter 6: On-site Open Space

Ch.6.other. Outdoor Amenities: Provide landscaping and seating in each open space type as follows: paseo, courtyards, plazas, roof terraces.

Ch.6.other. Outdoor Amenities: Ensure anti-skateboard and antigraffiti design features, pedestrian scaled signage that identifies uses and shops, site furniture, art work, or amenities such as fountains, seating, and kiosks.

Ch.6.other. Outdoor Amenities: Utilize buildings, colonnades and landscaping to define edges and create a sense of three-dimensional containment to urban open spaces and plazas.

Chapter 7: Architectural Detail

A.1. Provide well-marked entrances to cue access and use. Enhance all public entrances to a building through the use of compatible architectural or graphic treatment. Main building entrances shall read differently from retail storefronts, restaurants, and commercial entrances.

C.1. San Antonio has strong sun conditions. Use deep reveals to get shadow lines.

C.12. Prohibited Exterior Materials

1. Imitation stone (fiberglass or plastic);
2. Plywood or decorative exterior plywood;
3. Lumpy stucco, CMU;
4. Rough sawn or natural (unfinished)wood, EIFS;
5. Used brick with no fired face (salvaged from interior walls);
6. Imitation wood siding;
7. Plastic panels.

D.1. Reinforce a building's entry with one or more of the following architectural treatments:

- extra-height lobby space;
- distinctive doorways;
- decorative lighting;
- distinctive entry canopy;
- projected or deep recessed entry bay;
- building name and address integrated into the facade;
- artwork integrated into the facade or sidewalk;
- a change in paving material, texture, or color within the property line;
- distinctive landscaping, including plants, water features and seating.

E.1. Windows are to be as transparent as possible at the ground floor of the building, with preference given to grey, low-e glass (88 percent light transmission).

E.9. Parking and security lights shall not provide spillover to neighboring residential properties.

H.1. Exterior roll-down doors and security grills are not permitted in downtown

I.1. Ventilation intakes and exhausts shall be located to minimize adverse pedestrian impacts along the sidewalk.

I.4. No fixture shall be directed at the window of a residential unit either within or adjacent to a project.

Chapter 8: Streetscape Improvements

B.1. Sidewalks shall be paved with a slip resistant surface such as medium broom finish concrete.

B.2. Asphalt is not permitted for public sidewalks in downtown.

C.1. Crosswalks are to be provided at all types of street intersection configurations, including Xs, Ts and Ls.

E.8. Obtain a permit prior to pruning and adhere to International Society of Arboriculture (ISA) Tree Pruning Guidelines and American National Standards Institute (ANSI) A300 standards. These guidelines prohibit "topping" and "heading."

F.1. The street light pole shall be Valmont Tapered 16 Flat Fluting or similar. The pole shall be steel and be between 25 to 32 feet high. Pole base diameter shall be eight (8) inches. The mast arm shall be four (4) to six (6) foot "Windsor" or similar.

G. Site furniture must be well designed to encourage their use, be able to withstand the elements, and situated in appropriate locations and shaded, clustered in groupings near site features like fountains and in plazas, etc.

G.1. Site furniture on walkways and sidewalks shall maintain a clear passage for pedestrians and shall be placed to eliminate potential pedestrian and vehicular conflicts.

G.3. Design the lower portion of the buildings to support human scaled streetscapes, open spaces and quality pedestrian environments. This can be achieved with fine-grain architectural design and detailing, quality materials, and through the use of human-scaled elements such as landscaping, site furnishings, awnings, and canopies.

G.4. The following street furnishings are prohibited within the publicly owned portion of the right of way adjacent to streets or the River Walk:

- a. Vending machines
- b. Automatic teller machines
- c. Pay phones
- d. Photo booths
- e. Automated machines such as, but not limited to, blood pressure machines, fortunetelling machines, video games, animated characters and other machines that are internally illuminated, or have moving parts, or make noise, or have flashing lights.
- f. Inanimate figures such as horses, kangaroos, bears, gorillas, mannequins or any such animals, cartoon or human figure. This does not apply to public art approved by the Public Art Board.

Chapter 11: Sustainable Design

D.1. All projects must comply with the City's green building ordinance, Build San Antonio Green (BSAG).

Encouraged Design Guidelines

Chapter 2: Sidewalks and Setbacks

A.4. The continuous landscaped and hardscaped parkways should be designed to collect and retain or treat storm runoff.

A.5. In an ideal urban tree canopy, adjacent trees at street maturity generally touch one another. Therefore, typical tree spacing is generally 30 to 50 feet apart, depending upon the tree species.

A.6. Plant or replant street trees to shade and shelter the pedestrian from sun, rain and traffic, and to improve the quality of the air and storm water runoff.

A.8. Where tree wells and parkways would conflict with existing basements, underground vaults, historic paving materials, or other existing features that cannot be easily relocated the tree well and parkway design should be modified by the design to eliminate such conflicts. Parking meters and sign posts or signage are examples of existing features that can be easily relocated.

A.10. Install streetscape improvements as specified in Chapter 8--Streetscape Improvements.

A.11. All sidewalk improvements should be installed and maintained by the adjacent underlying property owners. For example, parkways and tree wells should be planted, irrigated and maintained by the adjacent property owners as described in Chapter 8.

A.12. New development should be landscaped or paved to match the adjacent public frontage.

B.2. Variations in the setback are encouraged to respond to building type and function in order to create visual interest.

Chapter 3: Ground Floor Treatment

A.11. Residential units with separate entries should include windows or glass doors on the ground floor that look out onto the street.

A.12. If a residential unit's individual entry along the street is the unit's primary entry, it should be accessible from the sidewalk.

A.13. More public entrances than the minimum specified by code, including building and or tenant and resident entrances are highly encouraged.

B.2. Street wall massing, articulation and detail, street level building entrances and storefront windows and doors, as well as the use of quality materials and decorative details should be used to promote pedestrian-scaled architecture along the street.

B.5. Electrical transformers, mechanical equipment and other equipment should not be located along the ground floor street wall.

Chapter 4: Parking and Access

A.3. Except for the minimum ground-level frontage required to access parking and loading areas, no parking or loading should be visible on the ground floor of any building façade that faces a street as seen in Figure 4.1.

A.5. On-street parking lanes may be converted to travel lanes during rush hour.

A.6. Provide on-street parking for visitors and customers.

A.8. Provide secure bicycle parking space for residential, commercial and institutional building occupants.

C.5. Where there is no alley and the project includes frontage on a street, parking access should be located mid-block or as far from a street intersection as possible.

Chapter 5: Massing and Street Wall

A.1. Divide large building facades into a series of appropriately scaled modules so that no building segment is more than 100 feet in length. Provide a passageway at least every 20 feet wide between buildings. Consider dividing a larger building into "modules" that are similar in scale.

A.2. Monolithic slab-like structures that wall off views and overshadow the surrounding neighborhood are discouraged.

- A.3. A new building should incorporate design elements that provide a base, middle and a top.
- A.4. A new building should, to the extent possible, maintain the alignment of horizontal elements along the block.
- A.5. Floor-to-floor heights should appear to be similar to those seen in the area, particularly the window fenestration.
- B.1. Street walls should be located against the back of sidewalk.
- B.2. Walls above the ground floor that step back from the ground floor street wall are considered to be part of the street wall.
- B.3. Breaks in the street wall should be limited to those necessary to accommodate pedestrian pass-throughs, public plazas, entry forecourts, permitted vehicular access driveways, and hotel drop-offs.
- B.5. Vertical breaks should also be taken into account with fenestration, such as columns or bays.

Chapter 6: On-site Open Space

Ch.6.3. At least 25 percent of the required trees should be canopy trees that shade open spaces, sidewalks and buildings.

Ch.6.other. Outdoor Amenities: Buffer seating areas from traffic; for example, position a planter between a bench and curb whenever possible.

Ch.6.other. Outdoor Amenities: Furniture and fixtures should be selected with regard to maintenance considerations. Ample seating in both shaded and sunny locations should be provided in the plaza areas. Street furniture should be located in close proximity to areas of high pedestrian activity and clustered in groupings. Barriers may be considered to separate pedestrian and dining activities through planters, rails and chain with bollards. However they should be moveable.

Ch.6.other. Landscape Elements to Provide Shade and Function:

- On roof terraces, incorporate trees and other plantings in permanent and temporary planters that will provide shade, reduce reflective glare, and add interest to the space. In addition, provide permanent and moveable seating that is placed with consideration to sun and shade, and other factors contributing to human comfort.
- Landscape elements should support an easy transition between indoor and outdoor through spaces, well-sited and comfortable steps, shading devices and/or planters that mark building entrances, etc., as seen in Figure 6.5.
- Landscape elements should establish scale and reinforce continuity between indoor and outdoor space. Mature canopy trees should be provided within open spaces, especially along streets and required setbacks.

Chapter 7: Architectural Detail

A.2. Avoid continuous massing longer than 150 feet not articulated with shadow relief, projections and recesses. If massing extends beyond this length, it needs to be visibly articulated as several smaller masses using different materials, vertical breaks, such as expressed bay widths, or other architectural elements.

A.3. Horizontal variation should be of an appropriate scale and reflect changes in the building uses or structure.

A.4. Vary details and materials horizontally to provide scale and three-dimensional qualities to the building.

A.5. While blank street wall façades are discouraged, there is usually one side of the building that is less prominent (often times called “back of house”).

B.1 Employ a different architectural treatment on the ground floor façade than on the upper floors, and feature high quality materials that add scale, texture and variety at the pedestrian level.

B.2. Vertically articulate the street wall façade, establishing different treatment for the building’s base, middle and top) and use balconies, fenestration, or other elements to create an interesting pattern of projections and recesses.

B.4. In order to respect existing historic datums, the cornice or roof line of historic structures should be reflected with a demarcation on new infill structures whenever possible.

B.5. On façades exposed to the sun, employ shade and shadow created by reveals, surface changes, overhangs and sunshades to provide sustainable benefits and visual interest.

C.2. Feature long-lived and local materials such as split limestone, brick and stone. The material palette should provide variety, reinforce massing and changes in the horizontal or vertical plane.

C.3. Use especially durable materials on ground floor façades.

C.4. Generally, stucco is not desirable on the ground floor as it is not particularly durable.

C.5. Detail buildings with rigor and clarity to reinforce the architect’s design intentions and to help set a standard of quality to guide the built results.

C.6. To provide visual variety and depth, layer the building skin and provide a variety of textures that bear a direct relationship to the building’s massing and structural elements. The skin should reinforce the integrity of the design concept and the building’s structural elements as seen in Figure 7.5 and 7.6 and not appear as surface pastiche.

C.7. Layering can also be achieved through extension of two adjacent building planes that are extended from the primary façade to provide a modern sculptural composition.

C.8. Cut outs (often used to create sky gardens) should be an appropriate scale and provide a comfortable, usable outdoor

space.

C.10. Design the color palette for a building to reinforce building identity and complement changes in the horizontal or vertical plane.

C.11. Value-added materials, such as stone should be placed at the base of the building, especially at the first floor level. Select materials suitable for a pedestrian urban environment. Impervious materials such as stone, metal or glass should be used on the building exterior. Materials will be made graffiti resistant or be easily repainted.

D.2. The primary entrance of all buildings will be off the public sidewalk as seen in Figure 7.7 and not from a parking area.

D.3. Strong colors should emphasize architectural details and entrances.

D.4. Deep recessed entries into the building are encouraged.

E.2. Window placement, size, material and style should help define a building's architectural style and integrity.

E.3. In buildings other than curtain wall buildings, windows should be recessed (set back) from the exterior building wall, except where inappropriate to the building's architectural style. Generally, the required recess may not be accomplished by the use of plant-ons around the window.

E.4. Windows and doors should be well-detailed where they meet the exterior wall to provide adequate weather protection and to create a shadow line.

E.5. Windows on upper floors should be proportioned and placed in relation to grouping of storefront or other windows and elements in the base floor.

F.1. Ground-floor window and door glazing should be transparent and non-reflective.

F.2. Above the ground floor, both curtain wall and window and door glazing should have the minimum reflectivity needed to achieve energy efficiency standards. Non-reflective coating or tints are preferred.

F.3. A limited amount of translucent glazing at the ground floor may be used to provide privacy.

G.1. Light fixtures less than 16 feet in height are considered pedestrian scale.

G.2. All exterior lighting (building and landscape) should be integrated with the building design, create a sense of safety, encourage pedestrian activity after dark, and support Downtown's vital nightlife.

G.3. Each project should develop a system or family of lighting layers that contribute to the night-time experience, including facade uplighting, sign and display window illumination, landscape, and streetscape lighting.

G.4. Architectural lighting should relate to the pedestrian and accentuate major architectural features.

G.5. Landscape lighting should be of a character and scale that relates to the pedestrian and highlights special landscape features.

G.6. Exterior lighting should be shielded to reduce glare and eliminate light being cast into the night sky.

G.7. In parking lots, a higher foot candle level should be provided at vehicle driveways, entry throats, pedestrian paths, plaza areas, and other activity areas.

G.8. Pedestrian-scale light fixtures should be of durable and vandal resistant materials and construction.

G.10. Integrate security lighting into the architectural and landscape lighting system. Security lighting should not be distinguishable from the project's overall lighting system.

I.1. Typically locating vents more than 20 feet vertically and horizontally from a sidewalk and directing the air flow away from the public realm will accomplish this objective.

I.2. Mechanical equipment should be either screened from public view or the equipment itself should be integrated with the architectural design of the building.

I.3. Penthouses should be integrated with the building's architecture, and not appear as foreign structures unrelated to the building they serve.

I.4. Lighting (exterior building and landscape) should be directed away from adjacent properties and roadways, and shielded as necessary.

I.5. Reflective materials or other sources of glare (like polished metal surfaces) should be designed or screened to not impact views nor result in measurable heat gain upon surrounding windows either within or adjacent to a project.

Chapter 8: Streetscape Improvements

A.2. The shared use of the public right of way is not only for moving vehicles, but equally as 1) the front door to businesses which provide an economic and fiscal foundation of the City and 2) outdoor open space for residents and workers.

A.3. All streets on which residential or commercial development is located are "pedestrian-oriented streets" and should be designed and improved accordingly.

C.2. Mid-block crosswalks should be provided on all blocks 550 feet or longer, subject to approval by San Antonio Public Works and/or Texas Department of Transportation (TxDOT), if State ROW.

C.4. Crosswalks should be clearly marked with high contrast “zebra” striping, unless some alternative design is provided as part of an integrated urban design for a specific street.

D.1. Decorative paving used in plaza and courtyard areas should complement the paving pattern and color of the pavers used in the public right-of-way.

D.3. Paving surfaces must be chosen for easy rollability.

E.2. Tree spacing and placement must be coordinated with street light placement as seen in Figure 8.4. Street lights should generally be located midway between adjacent trees, and are commonly spaced every two (2) or three (3) trees, hence 60 to 100 feet on center.

E.3. Street trees should be planted adjacent to a project when they cannot be accommodated on-site.

E.4. In the ideal urban tree canopy, adjacent trees at maturity generally touch one another. Therefore, the typical tree spacing is generally 40 feet, plus or minus 10 feet depending upon the tree species.

E.6. On streets where parking spaces are marked – either parallel or angled – trees should be located where they will not impede the opening of car doors or pedestrian access to the sidewalk. Where parking is parallel to the curb, trees are best positioned near the front or back of a space, so that they align with a fender rather than a door. Locating them on the line between two spaces tends to block access to the sidewalk and should be avoided.

E.7. Irrigate trees and landscaped parkways with an automatic irrigation system or Low Impact Development (LID) deep well. Deep root irrigation is preferred. Surface mounted spray heads or bubblers may also be used provided they adequately irrigate trees (minimum of 20 gallons per week dispersed over the root zone) and do not directly spray the tree trunks.

E.10. Where tree wells are installed, tree wells may be: 1) covered with a three (3) inch thick layer of stabilized decomposed granite, installed per manufacturer’s specifications, and level with the adjacent walkway; or 2) covered by an ADA compliant tree grate.

F.4. All street light or pedestrian light should have a Color Rendering Index of 80 or higher.

F.6. Lighting fixtures should be designed to complement the architecture of the project and improve visual identification of residences and businesses.

F.7. Pedestrian street lights may be set back from the curb on wide sidewalks installed on private property as follows:

- Where sidewalks are wide, the pedestrian lights may be set back between the clear path of travel and the commercial activity zone adjacent to the building.
- Where the building is set back from the sidewalk, the pedestrian street lights may be installed directly adjacent to the front property line.
- All light sources should provide a warm white light. Care should be given to not overly illuminate the sidewalk thereby ruining the pedestrian ambiance.
- All lighting systems should be cut-off, so as not to “spillover” light into adjacent buildings.

G.5. Bicycle racks (e.g., “loop rack” and “ribbon bar”) should be selected that are durable and consistent with other streetscape furnishings.

G.6. Street furnishings should be made of metal, stone, cast stone, hand sculpted concrete, or solid surfacing material, such as Corian or Surell. Recycled plastic will be considered on a case by case basis.

G.7. Benches, in particular, should be placed with careful consideration of their relationship to surrounding buildings and businesses. Benches placed perpendicular to the street are often best, as the sitter is neither staring at one storefront nor at passing traffic or sides of parked cars.

Ch. 8.H.1. Utility service to each building should be provided underground. If undergrounding utilities is not possible, install metal power poles at a consistent spacing that are located in bulb-outs to maintain an unobstructed sidewalk.

Ch. 8.H.3. Light poles should be separate from power poles.

Chapter 11: Sustainable Design

A.3. Orient projects to provide convenient access to the nearest transit options (bus, streetcar, trolley, bicycle), wherever possible.

C.1. Incorporate on-site landscape elements that reduce energy use and enhance livability.

FINDINGS:

- a. The applicant is requesting a Certificate of Appropriateness for approval to amend a previously approved design in regards to window installation depths and façade tile patterns. New construction was approved at this location on May 17, 2017. Modifications to the original design were approved by the HDRC on July 6, 2018, with the addresses of 307 Dwyer and 410 S Main, with the following stipulations:
 - i. That a more substantial building cap be installed through additional cap massing and/or a change in materials or color. **The applicant has met this stipulation.**
 - ii. That window frame color be presented to staff. White windows are not to be used. **The applicant has met this stipulation.**
- b. WINDOW RECESS – The applicant previously noted that all windows would be recessed a minimum of two (2) inches within walls to cast a shadow line and provide façade depths. At this time, the applicant has requested a modification to the recess of windows which includes the installation of stucco accents and trim around each window opening.
- c. FAÇADE TILE – The applicant has modified the pattern of the proposed façade tiles from the original design. Staff finds the updated design to be appropriate.

RECOMMENDATION:

1. Staff does not recommend approval of item #1, the elimination of the recess of at least two (2) inches for all exterior windows based on finding b.
2. Staff recommends approval of the proposed façade tile design based on finding c.

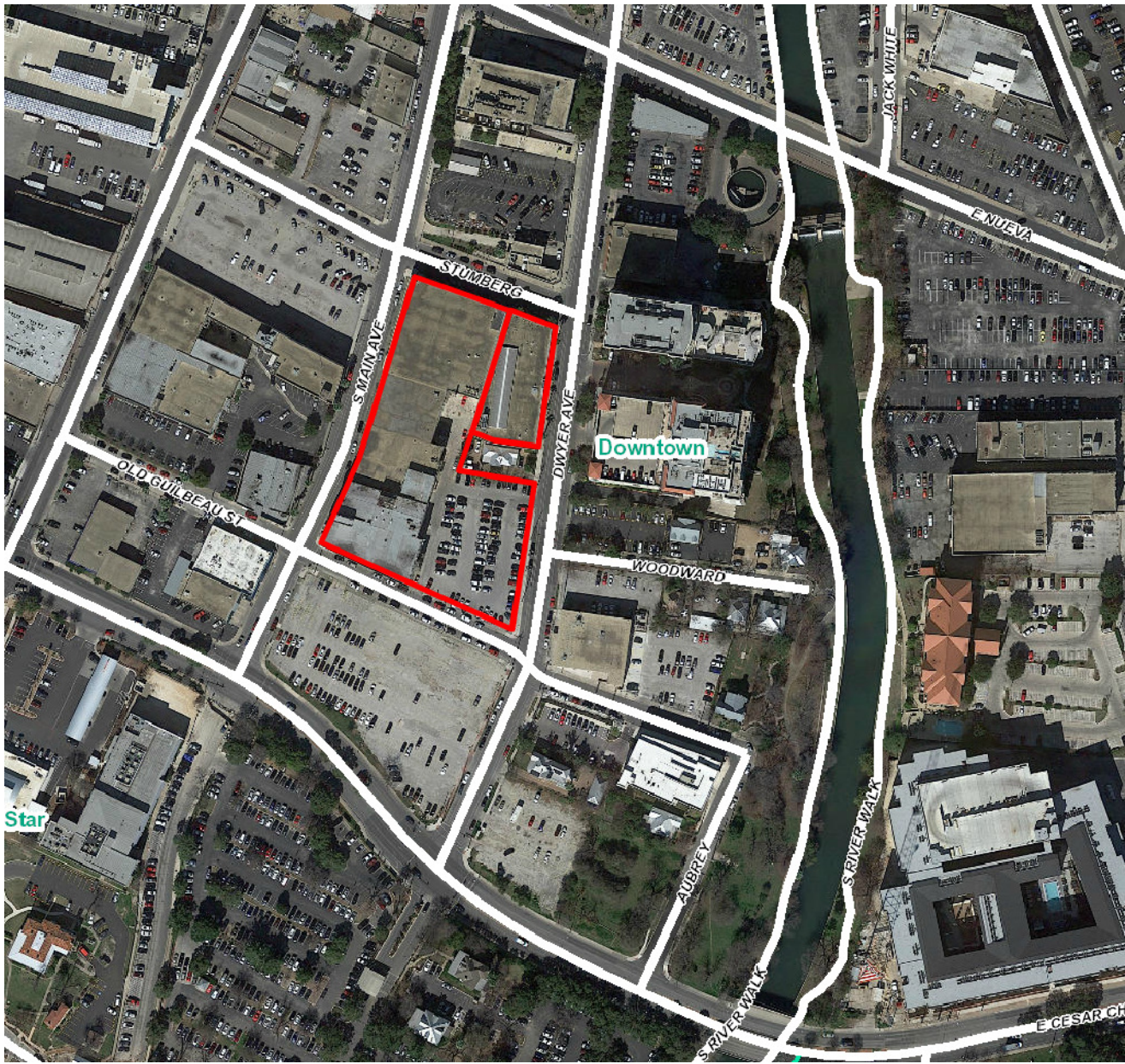

	<h2>Flex Viewer</h2>	<p>Printed: Jun 26, 2018</p>
	<p>Powered by ArcGIS Server</p>	

The City of San Antonio does not guarantee the accuracy, adequacy, completeness or usefulness of any information. The City does not warrant the completeness, timeliness, or positional, thematic, and attribute accuracy of the GIS data. The GIS data, cartographic products, and associated applications are not legal representations of the depicted data. Information shown on these maps is derived from public records that are constantly undergoing revision. Under no circumstances should GIS-derived products be used for final design purposes. The City provides this information on an "as is" basis without warranty of any kind, express or implied, including but not limited to warranties of merchantability or fitness for a particular purpose, and assumes no responsibility for anyone's use of the information.





- EFFICIENCIES
- ONE BEDROOM
- TWO BEDROOM
- RETAIL/ RESTAURANT
- LEASING/ AMENITIES
- GARAGE / SERVICES
- * ENTRY/ EXIT

SITE PLAN - LEVEL 1

HERITAGE PLAZA
 227 DWYER AVENUE
 SAN ANTONIO, TEXAS 78204

Job Number: 17006
 File Name: C:\Users\sullivan\Documents\Autodesk\Revit\17006_HP_Mixed-Use_A_18_rebeca.sullivan.rvt
 Date: 06/15/18
 Drawn by: RS



2808 Fairmount Street, Suite 300
 Dallas, Texas 75201 | 214.303.1500

3300 West 7th Street, Suite 110
 Fort Worth, Texas 76107 | 817.303.1500



LEVEL 2 & LEVEL 3

HERITAGE PLAZA
 227 DWYER AVENUE
 SAN ANTONIO, TEXAS 78204

Job Number: 17006
 File Name: C:\Users\rsullivan\Documents\Autodesk\Revit\17006_HP_Mixed-Use_A_18_rebeca.sullivan.rvt
 Date: 06/15/18
 Drawn by: RS



2808 Fairmount Street, Suite 300
 Dallas, Texas 75201 | 214.303.1500

3300 West 7th Street, Suite 110
 Fort Worth, Texas 76107 | 817.303.1500



LEVEL 4

HERITAGE PLAZA
 227 DWYER AVENUE
 SAN ANTONIO, TEXAS 78204

Job Number: 17006
 File Name: C:\Users\rsullivan\Documents\Autodesk\Revit\17006_HP_Mixed-Use_A_18_rebeca.sullivan.rvt
 Date: 06/15/18
 Drawn by: Author



2808 Fairmount Street, Suite 300
 Dallas, Texas 75201 | 214.303.1500

3300 West 7th Street, Suite 110
 Fort Worth, Texas 76107 | 817.303.1500



LEVEL 5

HERITAGE PLAZA
 227 DWYER AVENUE
 SAN ANTONIO, TEXAS 78204

Job Number: 17006
 File Name: C:\Users\rsullivan\Documents\Autodesk\Revit\17006_HP_Mixed-Use_A_18_rebeca.sullivan.rvt
 Date: 06/15/18
 Drawn by: RS



2808 Fairmount Street, Suite 300
 Dallas, Texas 75201 | 214.303.1500

3300 West 7th Street, Suite 110
 Fort Worth, Texas 76107 | 817.303.1500

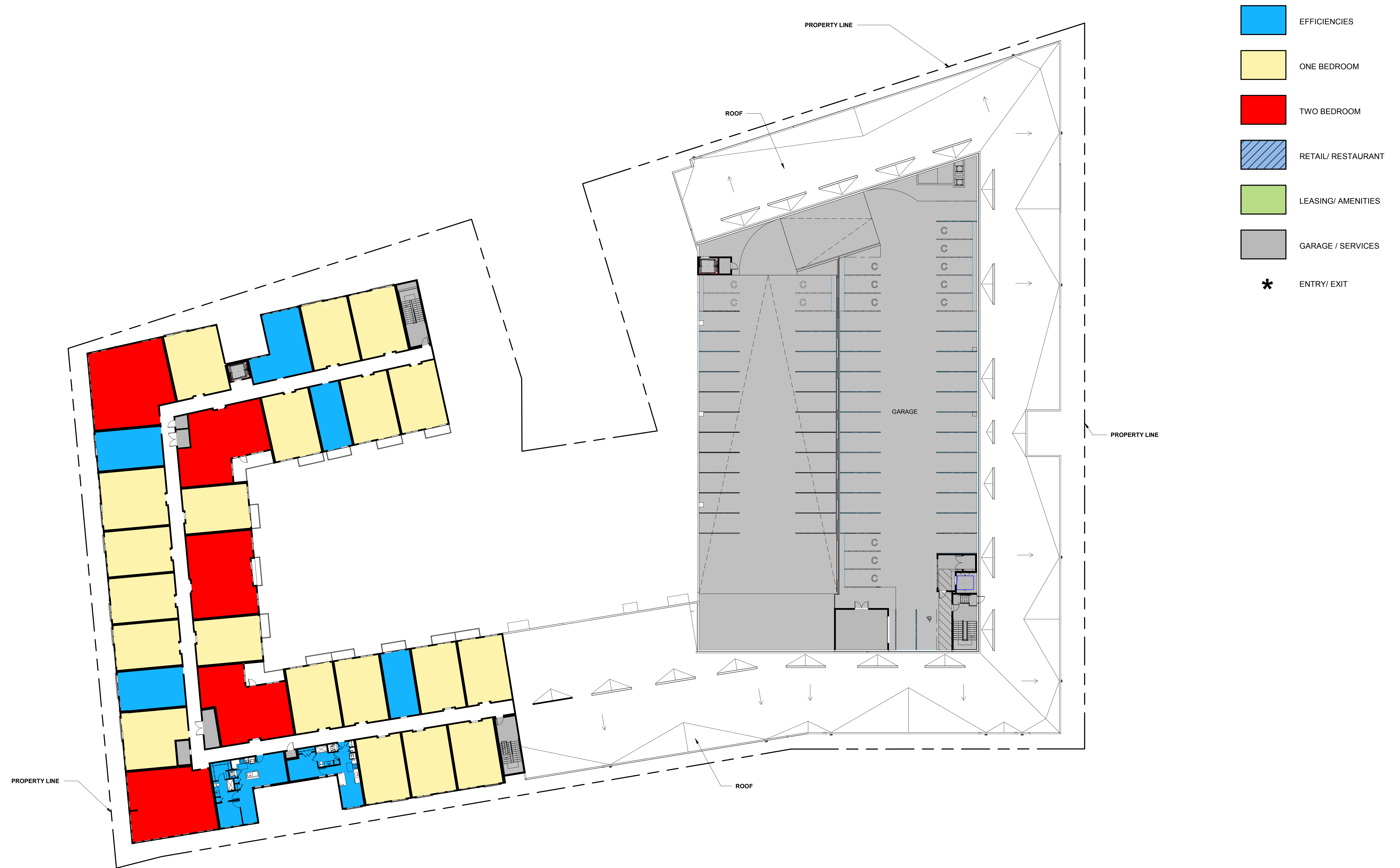

- EFFICIENCIES
- ONE BEDROOM
- TWO BEDROOM
- RETAIL/ RESTAURANT
- LEASING/ AMENITIES
- GARAGE / SERVICES
- * ENTRY/ EXIT

LEVEL 6

HERITAGE PLAZA
227 DWYER AVENUE
SAN ANTONIO, TEXAS 78204

Job Number: 17006
File Name: C:\Users\rsullivan\Documents\Autodesk\Revit\17006_HP_Mixed-Use_A_18_rebeca.sullivan.rvt
Date: 06/15/18
Drawn by: Author



2808 Fairmount Street, Suite 300
Dallas, Texas 75201 | 214.303.1500

3300 West 7th Street, Suite 110
Fort Worth, Texas 76107 | 817.303.1500



2 EAST ELEVATION - OVERALL
1/16" = 1'-0"



3 WEST ELEVATION - BUILDING A
1/16" = 1'-0"

MATERIAL LEGEND

- 1 CEMENT PLASTER STUCCO
- 2 PORCELAIN TILE
- 3 MASONRY
- 4 VINYL WINDOW/PATIO DOOR
- 5 PAINTED STEEL RAILING
- 6 METAL AWNING
- 7 STOREFRONT
- 8 PARAPET COPING

RENDERED ELEVATIONS

HERITAGE PLAZA
227 DWYER AVENUE
SAN ANTONIO, TEXAS 78204

Job Number: 17006
File Name: BIM 360://17006 - Argyle Heritage
Date: 04/29/2019a/17006_HP_Mixed-Use_A_18.rvt
Drawn by: Author



2808 Fairmount Street, Suite 300
Dallas, Texas 75201 | 214.303.1500

3300 West 7th Street, Suite 110
Fort Worth, Texas 76107 | 817.303.1500



3 NORTH ELEVATION - OVERALL
1/16" = 1'-0"

MATERIAL LEGEND

- ① CEMENT PLASTER STUCCO
- ② PORCELAIN TILE
- ③ MASONRY
- ④ VINYL WINDOW/PATIO DOOR
- ⑤ PAINTED STEEL RAILING
- ⑥ METAL AWNING
- ⑦ STOREFRONT
- ⑧ PARAPET COPING

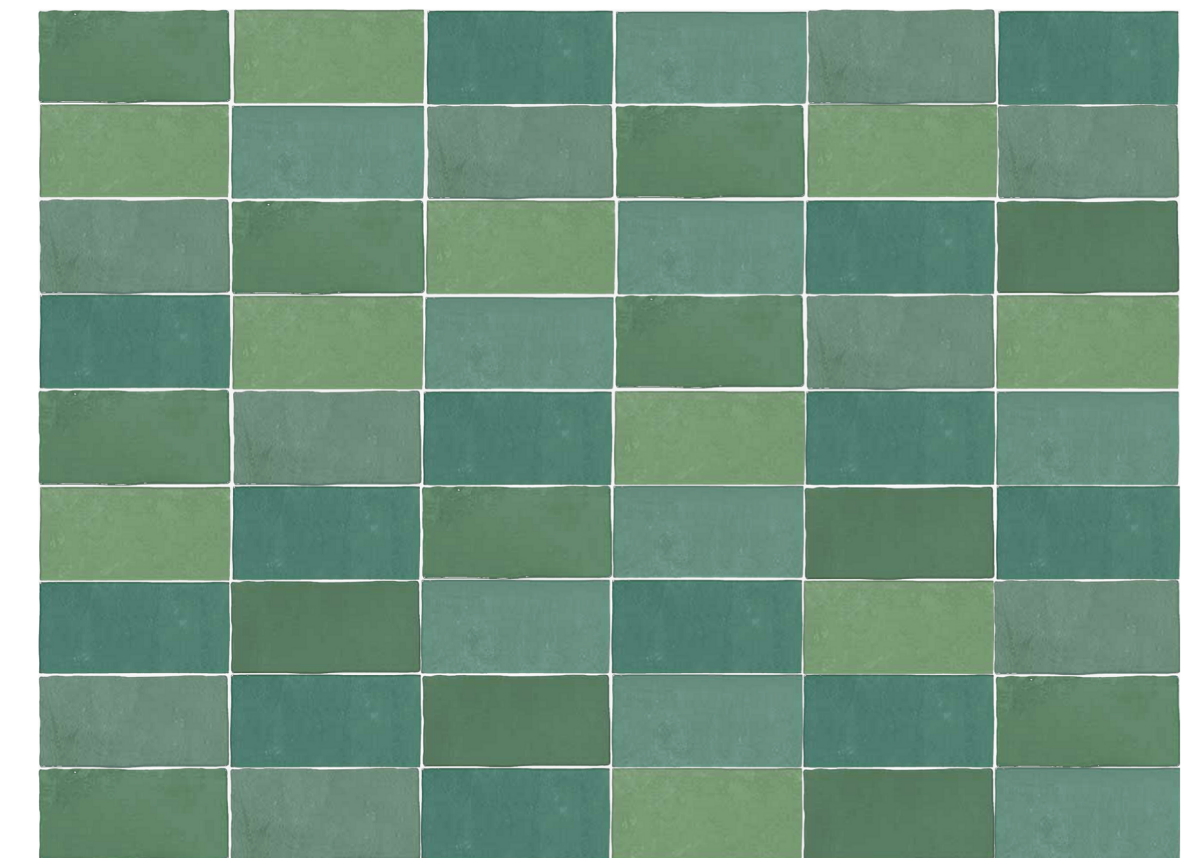

2 SOUTH ELEVATION - OVERALL
1/16" = 1'-0"



1 ENLARGED TYPICAL ELEVATION
3/16" = 1'-0"

RENDERED ELEVATIONS

HERITAGE PLAZA
 227 DWYER AVENUE
 SAN ANTONIO, TEXAS 78204

Job Number: 17006
 File Name: BIM 360://17006 - Argyle Heritage
 Date: 04/29/2019a/17006_HP_Mixed-Use_A_18.rvt
 Drawn by: Author



2808 Fairmount Street, Suite 300
 Dallas, Texas 75201 | 214.303.1500

3300 West 7th Street, Suite 110
 Fort Worth, Texas 76107 | 817.303.1500



EXTERIOR PORCELAIN TILE

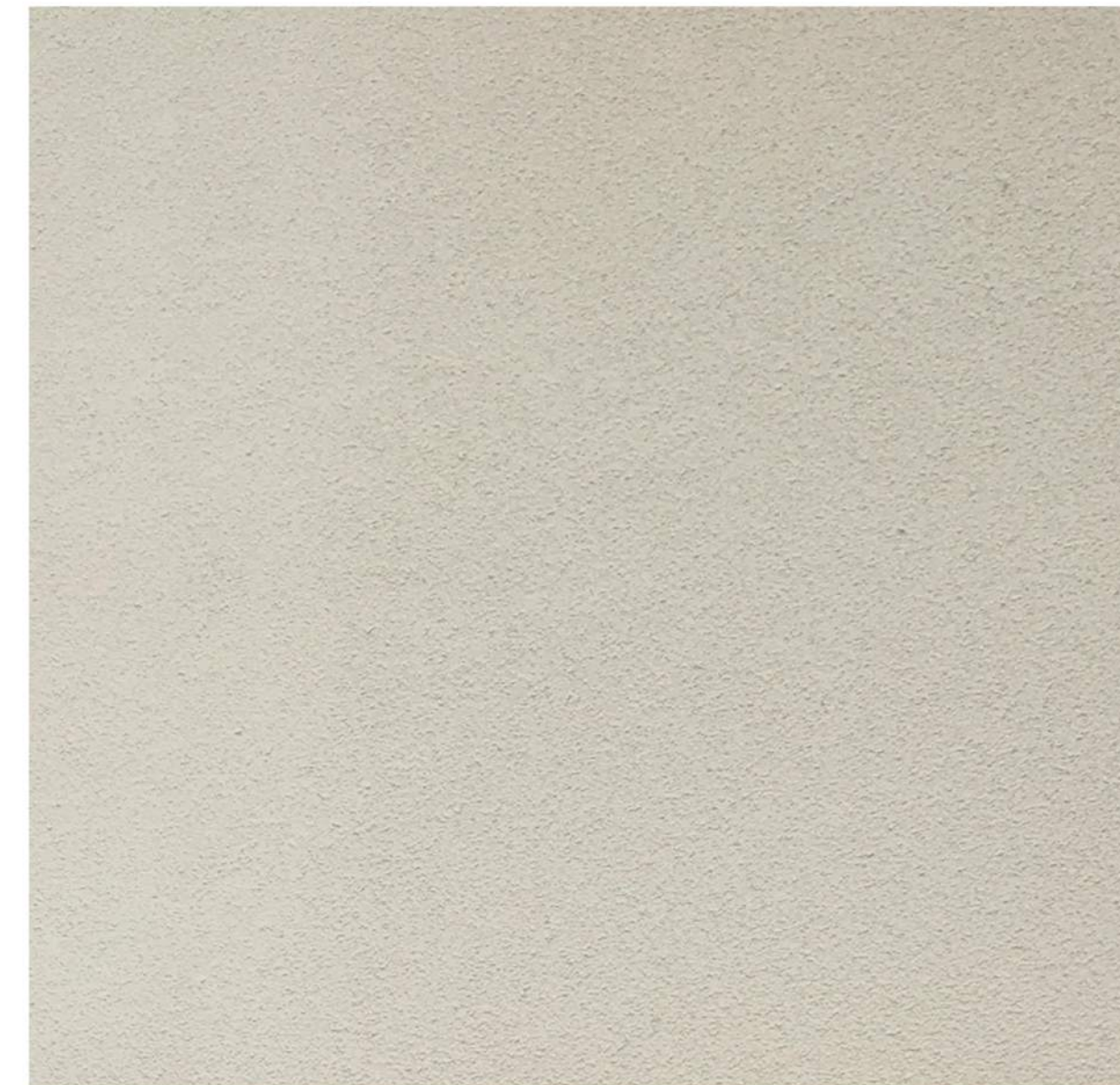

CEMENT PLASTER STUCCO

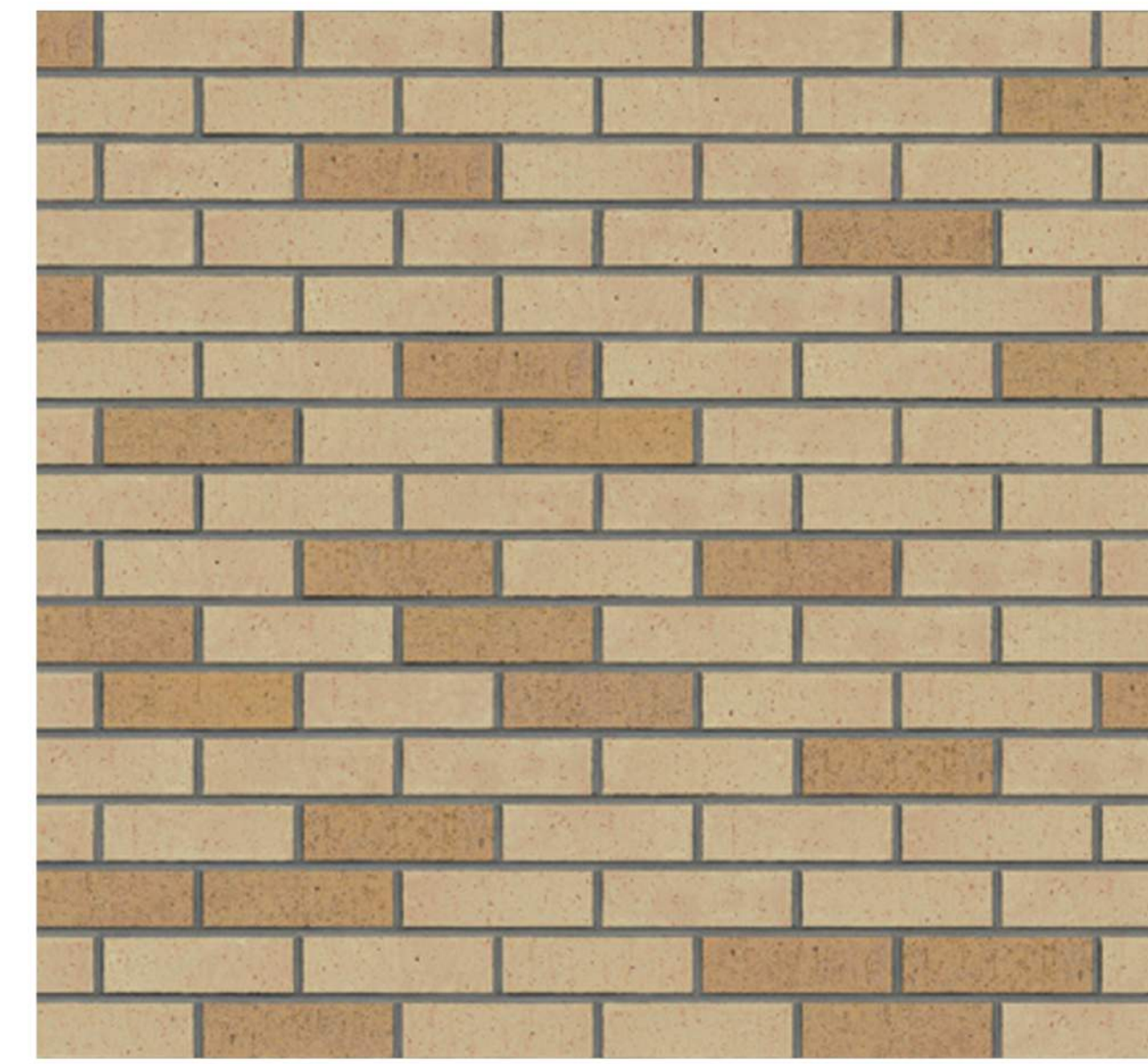

MASONRY



STOREFRONT

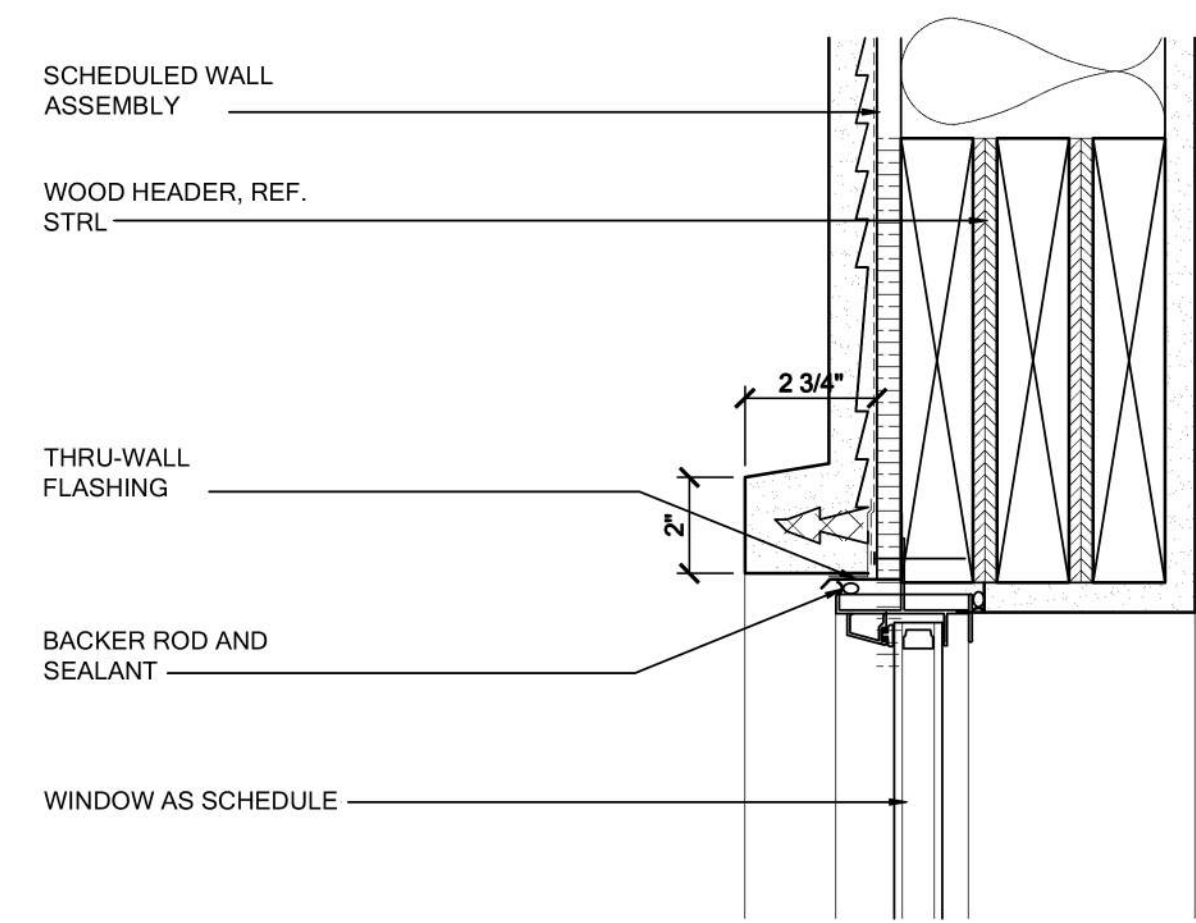

04 WINDOW HEAD AT CEMENT PLASTER

FILE NAME: D - Section Details.dwg SCALE: 3\"/>

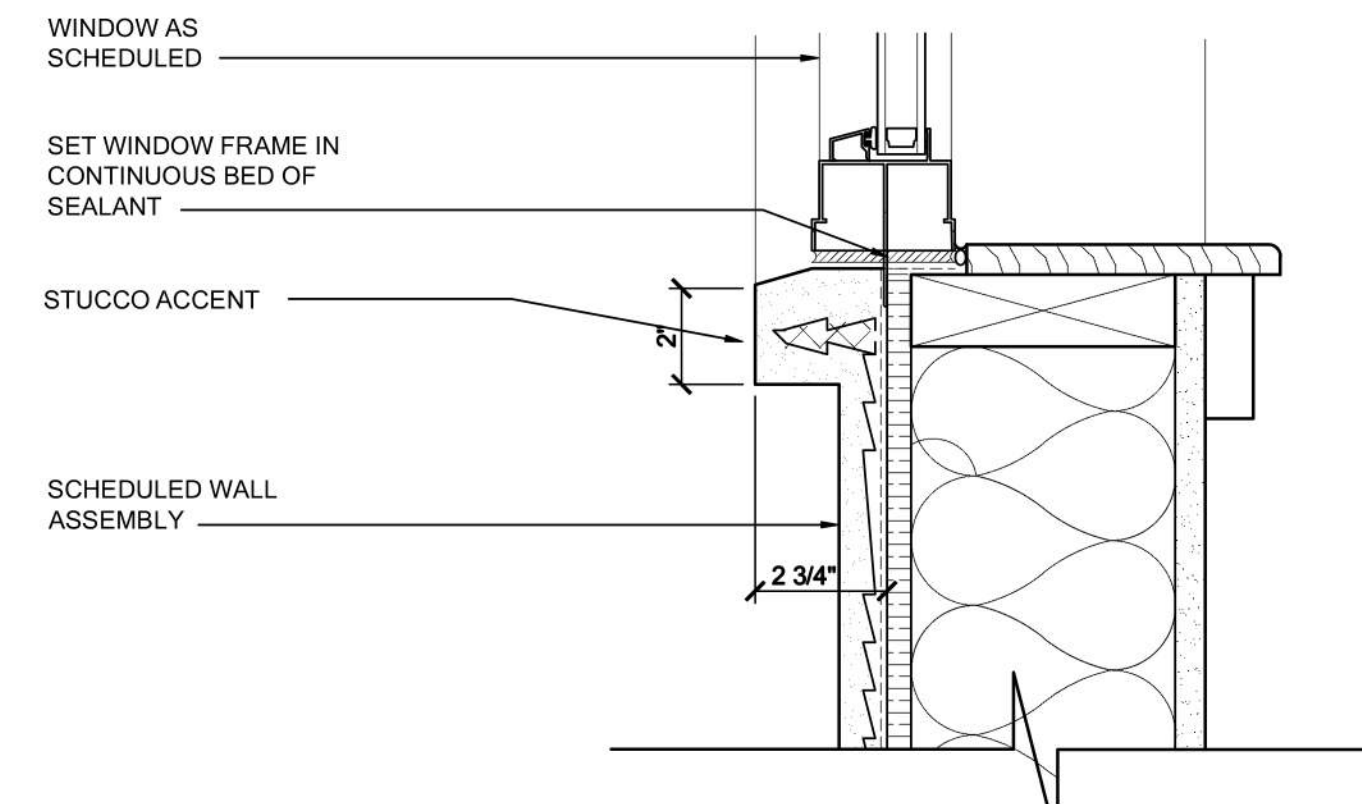

03 WINDOW SILL AT CEMENT PLASTER

FILE NAME: D - Section Details.dwg SCALE: 3\"/>

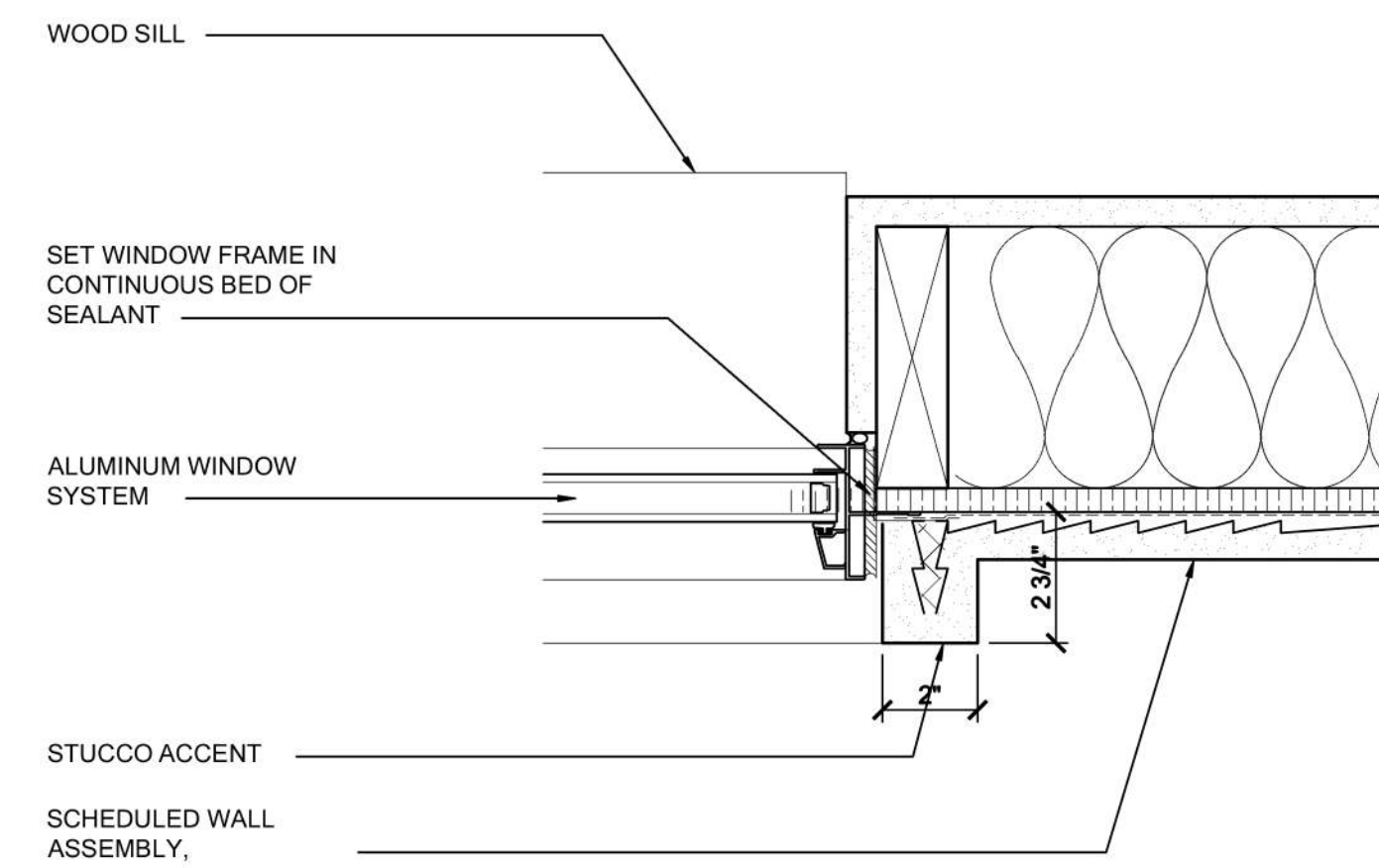

02 JAMB DETAIL AT CEMENT PLASTER

FILE NAME: D - Section Details.dwg SCALE: 3\"/>

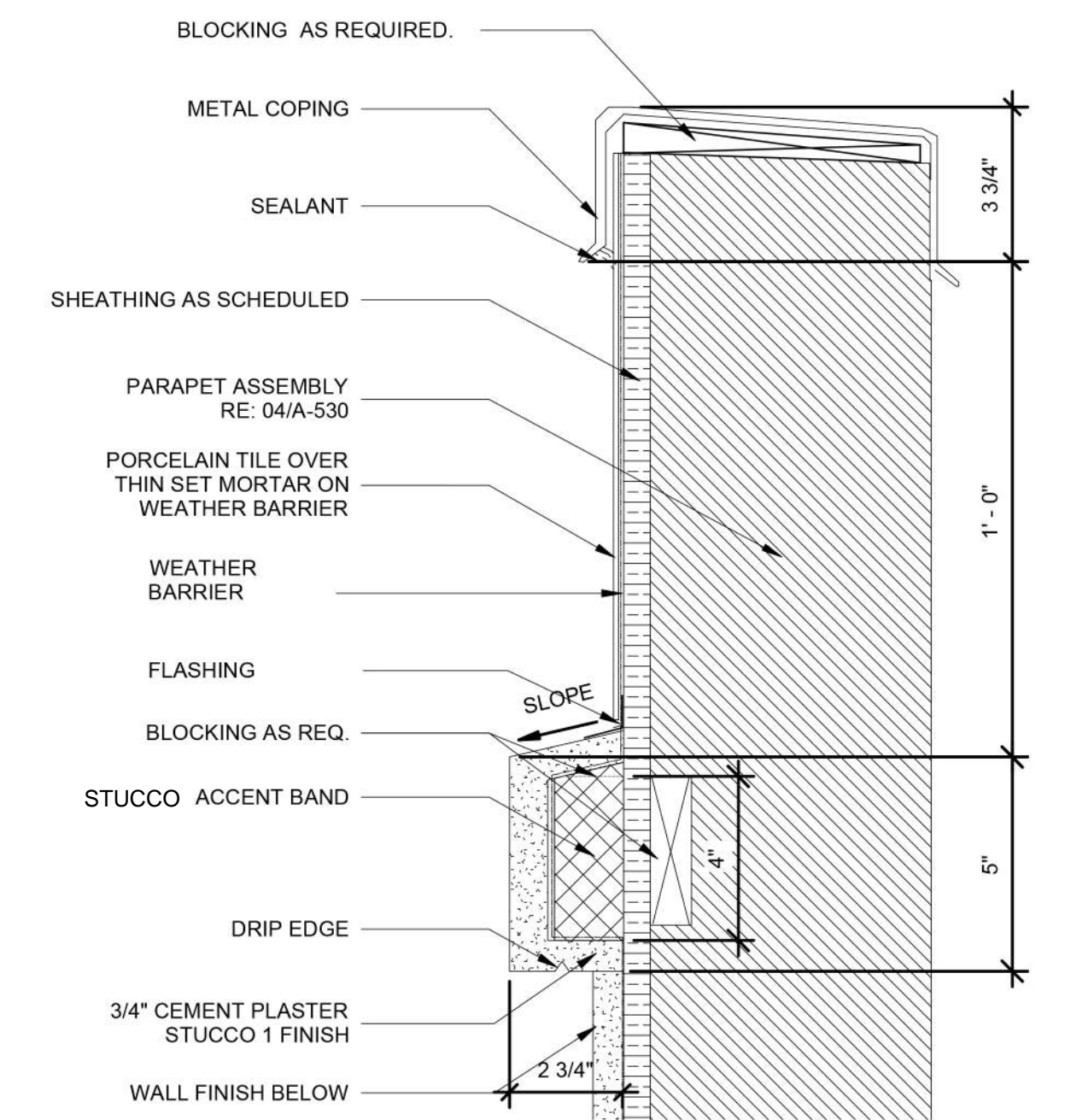

01 SECTION DETAIL

FILE NAME: D - Section Details.dwg SCALE: 3\"/>



2808 Fairmont Street, Suite 300
Dallas, Texas 75201 | 214.303.1500

3300 West 7th Street, Suite 110
Fort Worth, TX 76107 | 817.303.1500

