

FROM: R-6  
 TO: R-6 CD CONDITIONAL  
 USE FOR 2 DUPLEX

I, Eddie Saenz, the property owner, acknowledge that this site plan submitted for the purpose of rezoning this property is in accordance with all applicable provisions of the Unified Development Code. Additionally, I understand that City Council approval of a site plan in conjunction with a rezoning case does not relieve me from adherence to any/all City adopted Codes at the time of plan submittal for building permits.

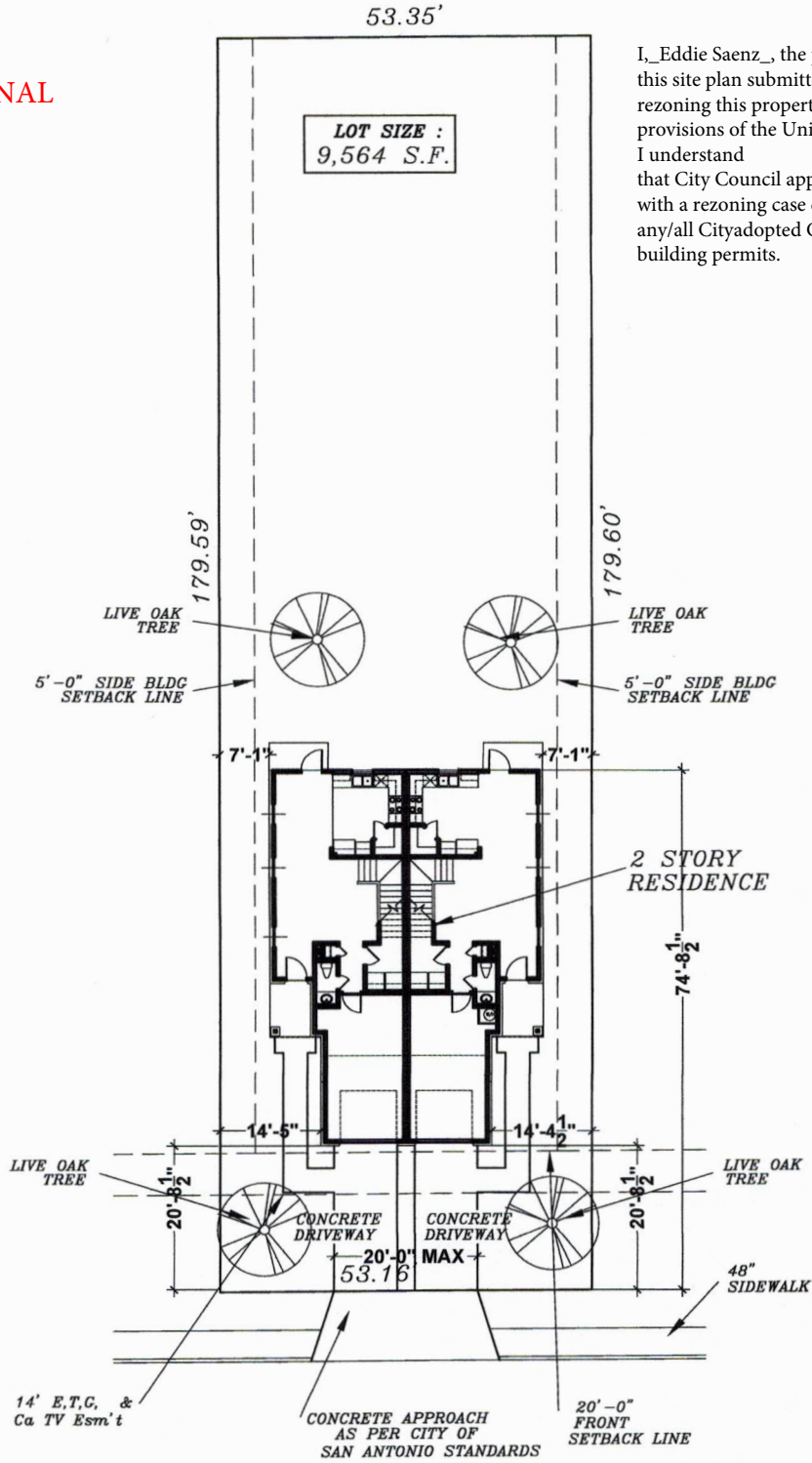

822 DARBY BLVD.

**SITE PLAN**

LEGAL DESCRIPTION	
LOT NO.	40
BLOCK NO.	1
N.C.B.	8116
ADDRESS:	822 DARBY BLVD.

N R N Homes, LLC SAN ANTONIO, TEXAS PHONE: 210-365-3198 FAX: 210-922-9599 NRNHOMES@GMAIL.COM	NAME: <b>DUPLEX ON DARBY BLVD.</b>	SCALE: N. T. S.
	ALL DIMENSIONS ARE IN FEET & INCHES UNLESS OTHERWISE NOTED	DATE: JUNE 4, 2019
ALL RIGHTS RESERVED. THIS PLAN MAY NOT BE REPRODUCED OR TRANSMITTED BY ANY MEANS W/O THE PRIOR PERMISSION OF N.R.N. HOMES		

FROM: R-6  
TO: R-6 CD CONDITIONAL USE  
FOR 2 DUPLEX

I, Eddie Saenz, the property owner, acknowledge that this site plan submitted for the purpose of rezoning this property is in accordance with all applicable provisions of the Unified Development Code. Additionally, I understand that City Council approval of a site plan in conjunction with a rezoning case does not relieve me from adherence to any/all City adopted Codes at the time of plan submittal for building permits.

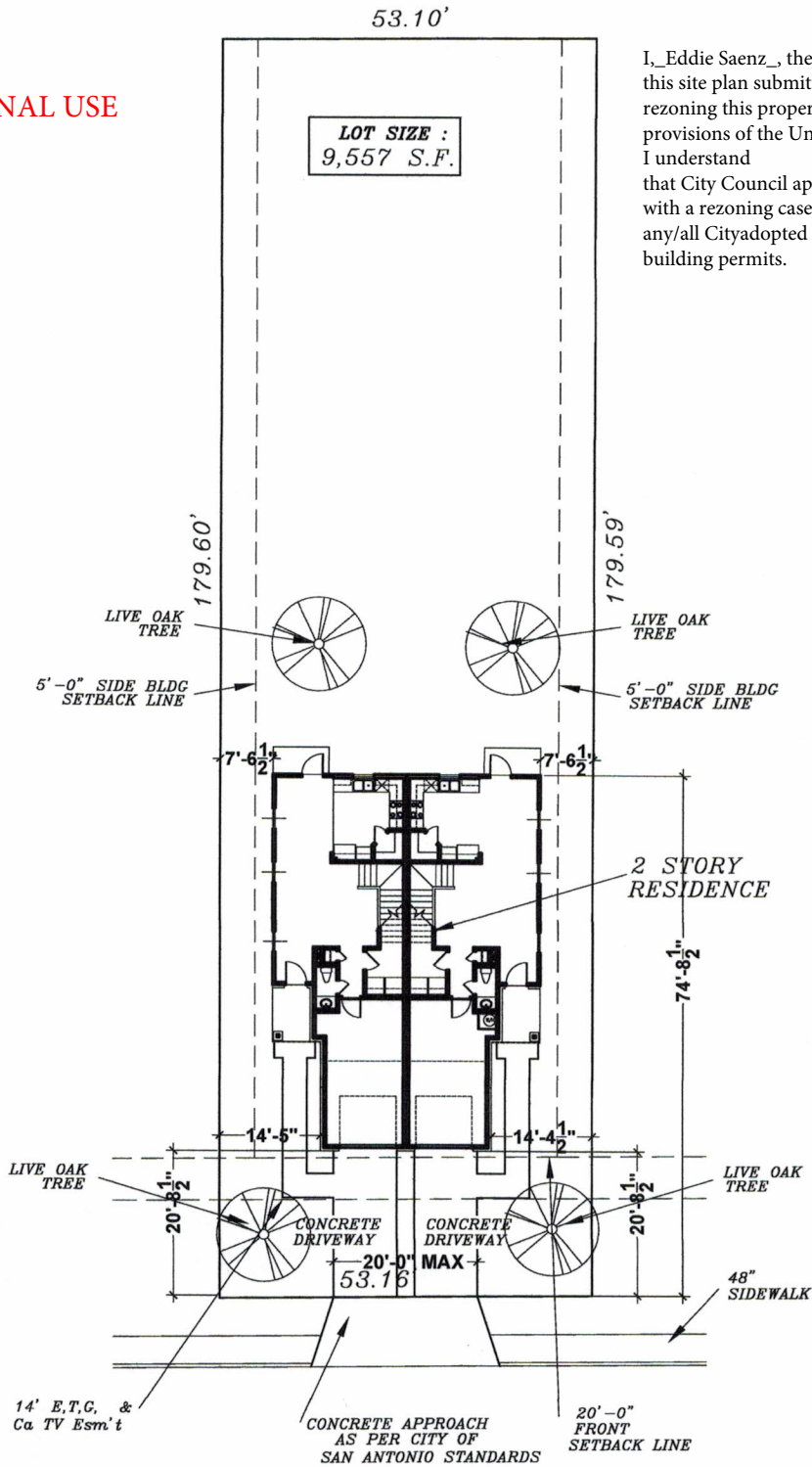

824 DARBY BLVD.

SITE PLAN

LEGAL DESCRIPTION

LOT NO. 39  
BLOCK NO. 1  
N.C.B. 8116  
ADDRESS: 824 DARBY BLVD.

N R N Homes, LLC SAN ANTONIO, TEXAS PHONE: 210-365-3198 FAX: 210-922-9599 N R N H O M E S @ G M A I L . C O M	NAME: DUPLEX ON DARBY BLVD.	SCALE: N. T. S.
	ALL DIMENSIONS ARE IN FEET & INCHES UNLESS OTHERWISE NOTED	DATE: JUNE 4, 2019
ALL RIGHTS RESERVED. THIS PLAN MAY NOT BE REPRODUCED OR TRANSMITTED BY ANY MEANS W/O THE PRIOR PERMISSION OF N.R.N. HOMES		